

LONDON 30CM Pendant

MLP097ANTBRS Antique Brass

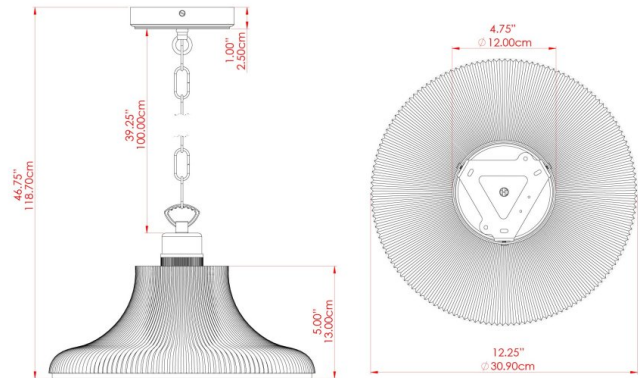

MATERIAL	Brass Glass
HEIGHT	7.25"
WIDTH DIAMETER	12.75"
LENGTH PROJECTION	n/a
WEIGHT	1.6 kg 3.5 lbs
LAMPHOLDER	E26
MAX WATTAGE	40W
VOLTAGE	110/120v
ENVIRONMENTAL RATING	Dry Location (IP20)
CLASS PROTECTION	Class I
SHADE	GL099
FLEX BAR CHAIN LENGTH	40"
CABLE TYPE	MLCA010 Brown PVC Flexible Cable 2 Core

FIXING BRACKET: MLROSE39 | Antique Brass

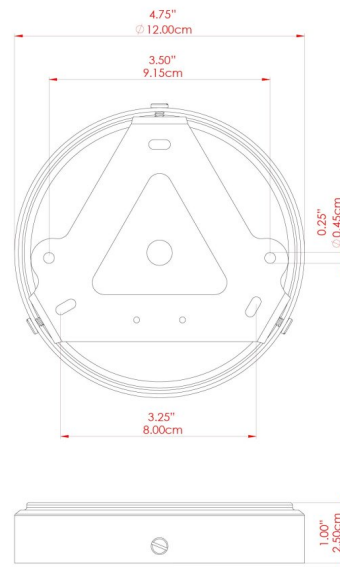

Product Notes:
 1) Bulbs not included. 2) Dimensions do not include bulbs. 3) All products are individually made-to-order and therefore may differ slightly within manufacturing tolerances. 4) Cable / chain can be shortened during installation. Longer cable / chain lengths available on request. 5) Additional color finishes may be available on request. 6) Twisted cable is not available for UL wired products. Round cable in black or brown only is supplied instead. 7) Refer to our website for a full list of terms and conditions.



LONDON 30CM Pendant

MLP097ANTSLV Antique Silver

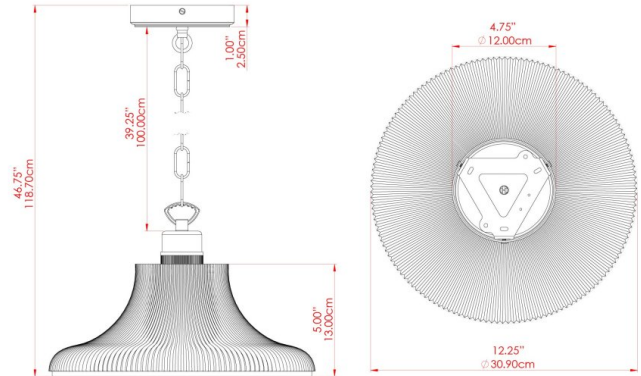

MATERIAL	Brass Glass
HEIGHT	7.25"
WIDTH DIAMETER	12.75"
LENGTH PROJECTION	n/a
WEIGHT	1.6 kg 3.5 lbs
LAMPHOLDER	E26
MAX WATTAGE	40W
VOLTAGE	110/120v
ENVIRONMENTAL RATING	Dry Location (IP20)
CLASS PROTECTION	Class I
SHADE	GL099
FLEX BAR CHAIN LENGTH	40"
CABLE TYPE	MLCA014 Clear PVC Flexible Cable 2 Core

FIXING BRACKET: MLROSE39 | Antique Silver

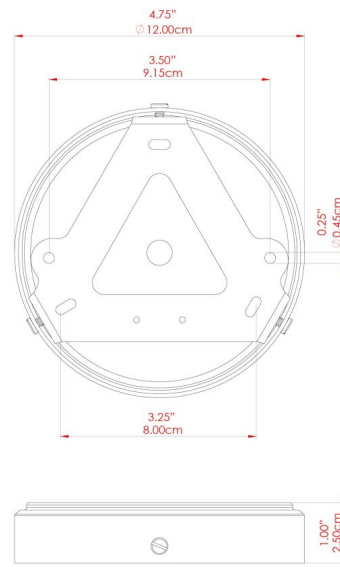

Product Notes:
 1) Bulbs not included. 2) Dimensions do not include bulbs. 3) All products are individually made-to-order and therefore may differ slightly within manufacturing tolerances. 4) Cable / chain can be shortened during installation. Longer cable / chain lengths available on request. 5) Additional color finishes may be available on request. 6) Twisted cable is not available for UL wired products. Round cable in black or brown only is supplied instead. 7) Refer to our website for a full list of terms and conditions.



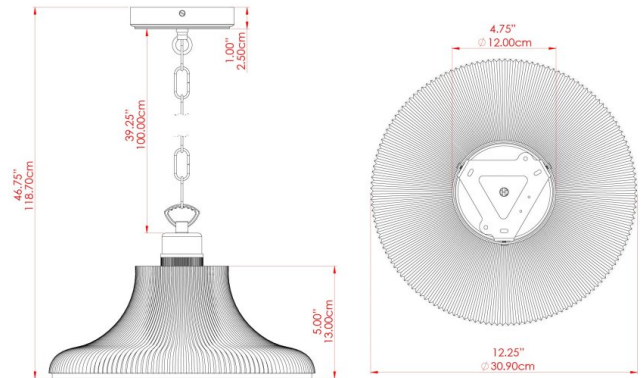

MATERIAL	Brass Glass
HEIGHT	7.25"
WIDTH DIAMETER	12.75"
LENGTH PROJECTION	n/a
WEIGHT	1.6 kg 3.5 lbs
LAMPHOLDER	E26
MAX WATTAGE	40W
VOLTAGE	110/120v
ENVIRONMENTAL RATING	Dry Location (IP20)
CLASS PROTECTION	Class I
SHADE	GL099 x1
FLEX BAR CHAIN LENGTH	40"
CABLE TYPE	

FIXING BRACKET: MLROSE39 | Black

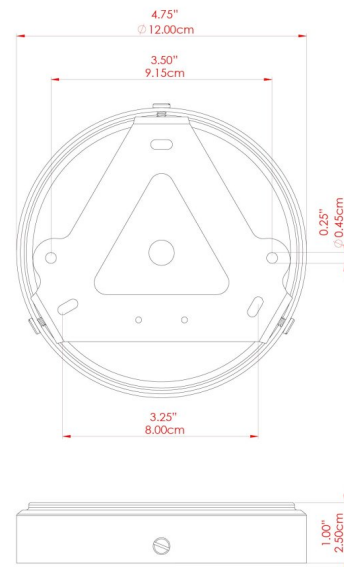

Product Notes:
 1) Bulbs not included. 2) Dimensions do not include bulbs. 3) All products are individually made-to-order and therefore may differ slightly within manufacturing tolerances. 4) Cable / chain can be shortened during installation. Longer cable / chain lengths available on request. 5) Additional color finishes may be available on request. 6) Twisted cable is not available for UL wired products. Round cable in black or brown only is supplied instead. 7) Refer to our website for a full list of terms and conditions.



LONDON 30CM Pendant

MLP097PCMBK Matt Black

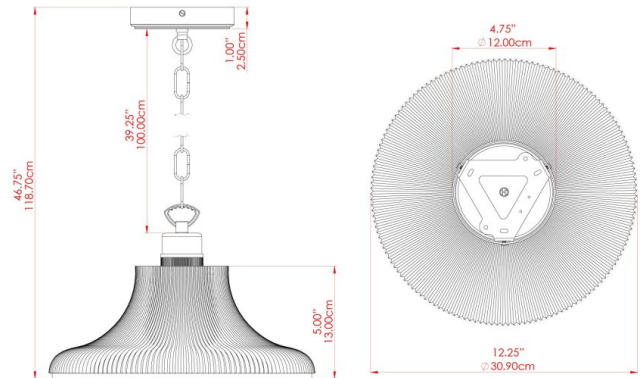

MATERIAL	Brass Glass
HEIGHT	7.25"
WIDTH DIAMETER	12.75"
LENGTH PROJECTION	n/a
WEIGHT	1.6 kg 3.5 lbs
LAMPHOLDER	E26
MAX WATTAGE	40W
VOLTAGE	110/120v
ENVIRONMENTAL RATING	Dry Location (IP20)
CLASS PROTECTION	Class I
SHADE	GL099 x1
FLEX BAR CHAIN LENGTH	40"
CABLE TYPE	

FIXING BRACKET: MLROSE39 | Matt Black

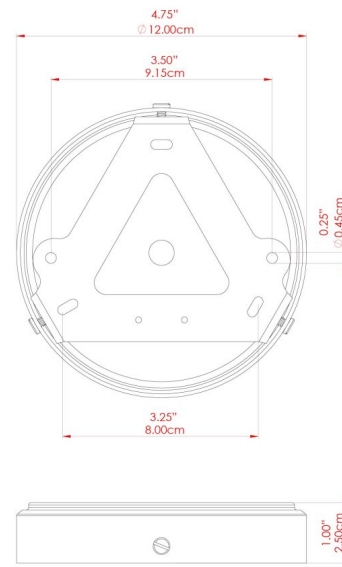

Product Notes:

1) Bulbs not included. 2) Dimensions do not include bulbs. 3) All products are individually made-to-order and therefore may differ slightly within manufacturing tolerances. 4) Cable / chain can be shortened during installation. Longer cable / chain lengths available on request. 5) Additional color finishes may be available on request. 6) Twisted cable is not available for UL wired products. Round cable in black or brown only is supplied instead. 7) Refer to our website for a full list of terms and conditions.



LONDON 30CM Pendant

MLP097PCWTE White

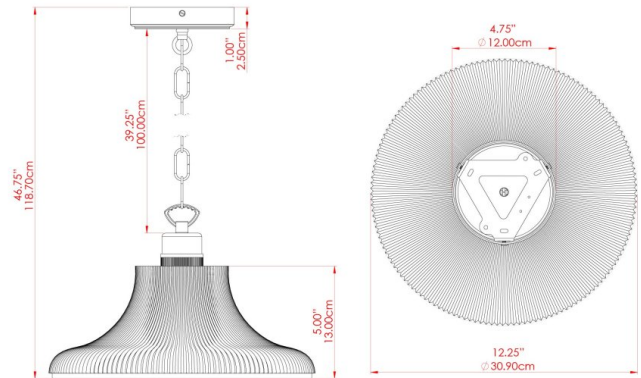

MATERIAL	Brass Glass
HEIGHT	7.25"
WIDTH DIAMETER	12.75"
LENGTH PROJECTION	n/a
WEIGHT	1.6 kg 3.5 lbs
LAMPHOLDER	E26
MAX WATTAGE	40W
VOLTAGE	110/120v
ENVIRONMENTAL RATING	Dry Location (IP20)
CLASS PROTECTION	Class I
SHADE	GL099 x1
FLEX BAR CHAIN LENGTH	40"
CABLE TYPE	

FIXING BRACKET: MLROSE39 | White

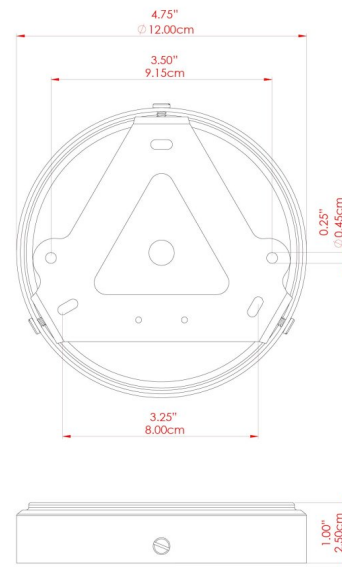

Product Notes:
 1) Bulbs not included. 2) Dimensions do not include bulbs. 3) All products are individually made-to-order and therefore may differ slightly within manufacturing tolerances. 4) Cable / chain can be shortened during installation. Longer cable / chain lengths available on request. 5) Additional color finishes may be available on request. 6) Twisted cable is not available for UL wired products. Round cable in black or brown only is supplied instead. 7) Refer to our website for a full list of terms and conditions.



LONDON 30CM Pendant

MLP097POLBRS Polished Brass

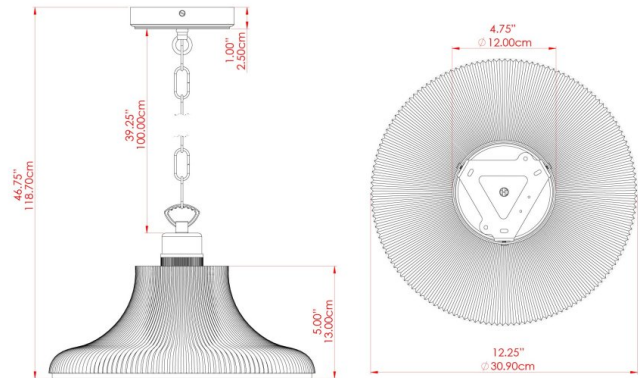

MATERIAL	Brass Glass
HEIGHT	7.25"
WIDTH DIAMETER	12.75"
LENGTH PROJECTION	n/a
WEIGHT	1.6 kg 3.5 lbs
LAMPHOLDER	E26
MAX WATTAGE	40W
VOLTAGE	110/120v
ENVIRONMENTAL RATING	Dry Location (IP20)
CLASS PROTECTION	Class I
SHADE	GL099
FLEX BAR CHAIN LENGTH	40"
CABLE TYPE	MLCA038 Gold PVC Flexible Cable 2 Core

FIXING BRACKET: MLROSE39 | Polished Brass

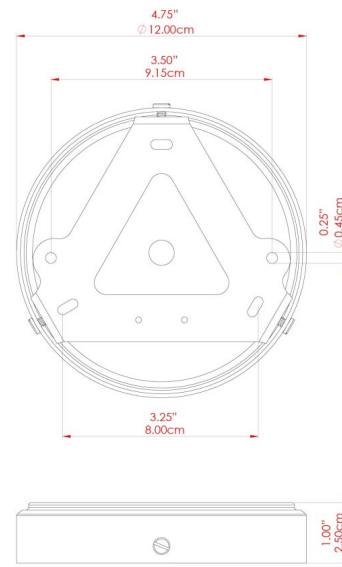

Product Notes:

1) Bulbs not included. 2) Dimensions do not include bulbs. 3) All products are individually made-to-order and therefore may differ slightly within manufacturing tolerances. 4) Cable / chain can be shortened during installation. Longer cable / chain lengths available on request. 5) Additional color finishes may be available on request. 6) Twisted cable is not available for UL wired products. Round cable in black or brown only is supplied instead. 7) Refer to our website for a full list of terms and conditions.



LONDON 30CM Pendant

MLP097POLCHR Polished Chrome

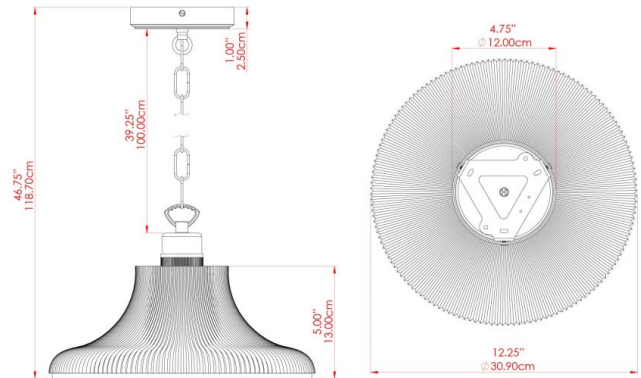

MATERIAL	Brass Glass
HEIGHT	7.25"
WIDTH DIAMETER	12.75"
LENGTH PROJECTION	n/a
WEIGHT	1.6 kg 3.5 lbs
LAMPHOLDER	E26
MAX WATTAGE	40W
VOLTAGE	110/120v
ENVIRONMENTAL RATING	Dry Location (IP20)
CLASS PROTECTION	Class I
SHADE	GL099
FLEX BAR CHAIN LENGTH	40"
CABLE TYPE	MLCA014 Clear PVC Flexible Cable 2 Core

FIXING BRACKET: MLROSE39 | Polished Chrome

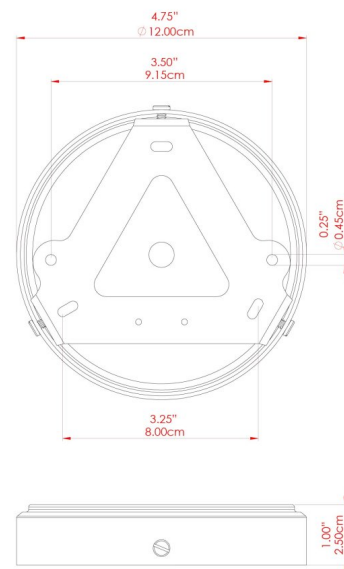

Product Notes:
 1) Bulbs not included. 2) Dimensions do not include bulbs. 3) All products are individually made-to-order and therefore may differ slightly within manufacturing tolerances. 4) Cable / chain can be shortened during installation. Longer cable / chain lengths available on request. 5) Additional color finishes may be available on request. 6) Twisted cable is not available for UL wired products. Round cable in black or brown only is supplied instead. 7) Refer to our website for a full list of terms and conditions.



LONDON 30CM Pendant

MLP097SATBRS Satin Brass

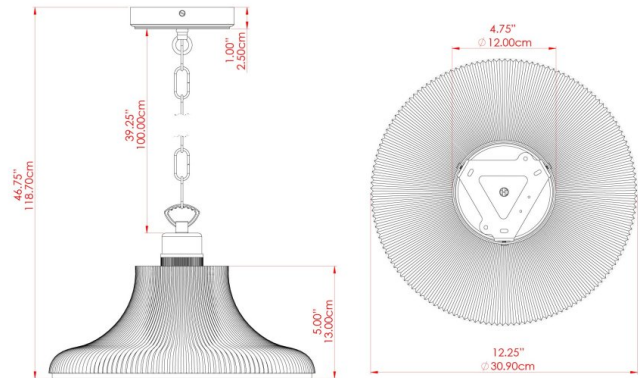

MATERIAL	Brass Glass
HEIGHT	7.25"
WIDTH DIAMETER	12.75"
LENGTH PROJECTION	n/a
WEIGHT	1.6 kg 3.5 lbs
LAMPHOLDER	E26
MAX WATTAGE	40W
VOLTAGE	110/120v
ENVIRONMENTAL RATING	Dry Location (IP20)
CLASS PROTECTION	Class I
SHADE	GL099
FLEX BAR CHAIN LENGTH	40"
CABLE TYPE	MLCA038 Gold PVC Flexible Cable 2 Core

FIXING BRACKET: MLROSE39 | Satin Brass

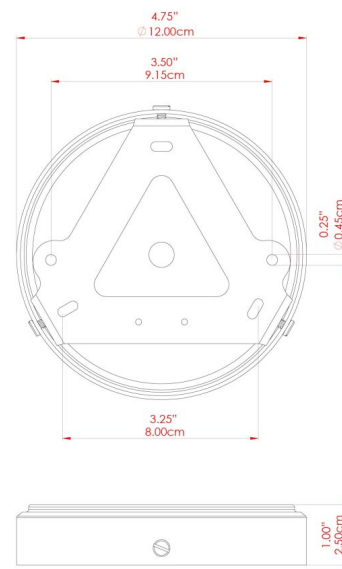

Product Notes:

1) Bulbs not included. 2) Dimensions do not include bulbs. 3) All products are individually made-to-order and therefore may differ slightly within manufacturing tolerances. 4) Cable / chain can be shortened during installation. Longer cable / chain lengths available on request. 5) Additional color finishes may be available on request. 6) Twisted cable is not available for UL wired products. Round cable in black or brown only is supplied instead. 7) Refer to our website for a full list of terms and conditions.



LONDON 30CM Pendant

MLP097SATCHR Satin Chrome

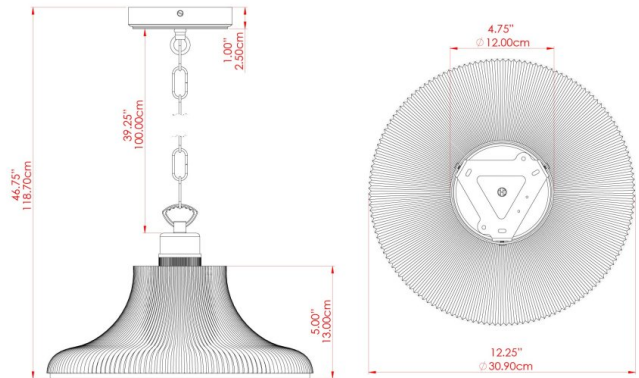

MATERIAL	Brass Glass
HEIGHT	7.25"
WIDTH DIAMETER	12.75"
LENGTH PROJECTION	n/a
WEIGHT	1.6 kg 3.5 lbs
LAMPHOLDER	E26
MAX WATTAGE	40W
VOLTAGE	110/120v
ENVIRONMENTAL RATING	Dry Location (IP20)
CLASS PROTECTION	Class I
SHADE	GL099
FLEX BAR CHAIN LENGTH	40"
CABLE TYPE	MLCA014 Clear PVC Flexible Cable 2 Core

FIXING BRACKET: MLROSE39 | Satin Chrome

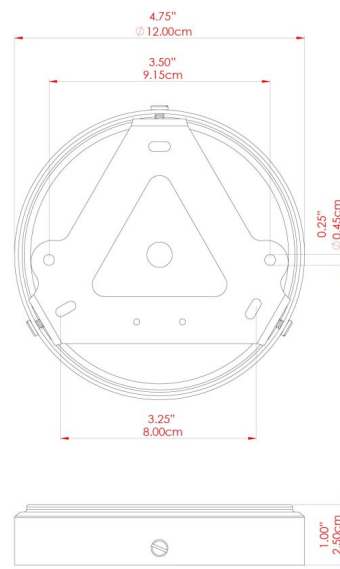

Product Notes:
 1) Bulbs not included. 2) Dimensions do not include bulbs. 3) All products are individually made-to-order and therefore may differ slightly within manufacturing tolerances. 4) Cable / chain can be shortened during installation. Longer cable / chain lengths available on request. 5) Additional color finishes may be available on request. 6) Twisted cable is not available for UL wired products. Round cable in black or brown only is supplied instead. 7) Refer to our website for a full list of terms and conditions.

