

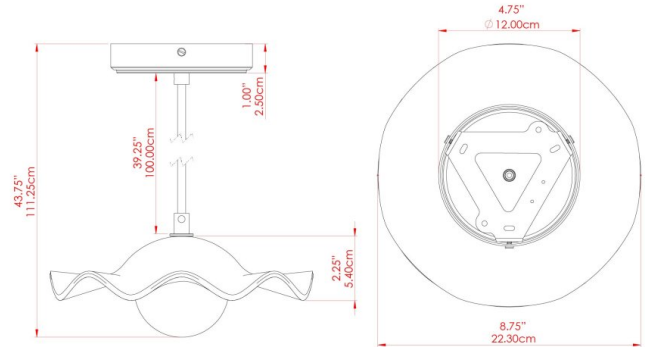

RIVALE Ceramic Pendant

MLCMP056ANTBRSOP Antique Brass



MATERIAL	Ceramic Brass Glass
HEIGHT	3.25"
WIDTH DIAMETER	8.25"
LENGTH PROJECTION	n/a
WEIGHT	0.6 kg 1.3 lbs
LAMPHOLDER	G9
MAX WATTAGE	6.5W
VOLTAGE	110/120v
ENVIRONMENTAL RATING	Dry Location (IP20)
CLASS PROTECTION	Class I
SHADE	GL192 MLCS063
FLEX BAR CHAIN LENGTH	40"
CABLE TYPE	MLCA047 Brown Fabric Braided Cable 2 Core Round

FIXING BRACKET: MLWB17

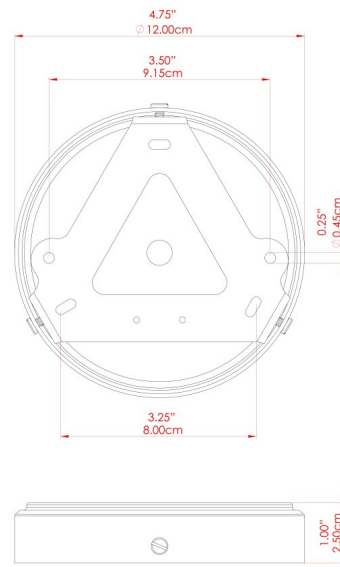

Product Notes:
 1) Bulbs not included. 2) Dimensions do not include bulbs. 3) All products are individually made-to-order and therefore may differ slightly within manufacturing tolerances. 4) Cable / chain can be shortened during installation. Longer cable / chain lengths available on request. 5) Additional color finishes may be available on request. 6) Twisted cable is not available for UL wired products. Round cable in black or brown only is supplied instead. 7) Refer to our website for a full list of terms and conditions.





RIVALE Ceramic Pendant

MLCMP056ANTSLVOP Antique Silver

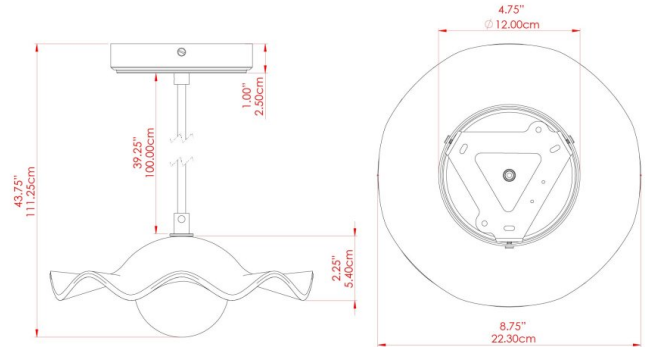

MATERIAL	Ceramic Brass Glass
HEIGHT	3.25"
WIDTH DIAMETER	8.25"
LENGTH PROJECTION	n/a
WEIGHT	0.6 kg 1.3 lbs
LAMPHOLDER	G9
MAX WATTAGE	6.5W
VOLTAGE	110/120v
ENVIRONMENTAL RATING	Dry Location (IP20)
CLASS PROTECTION	Class I
SHADE	GL192 MLCS063
FLEX BAR CHAIN LENGTH	40"
CABLE TYPE	MLCA028 Black Fabric Braided Cable 2 Core Round

FIXING BRACKET: MLWB17

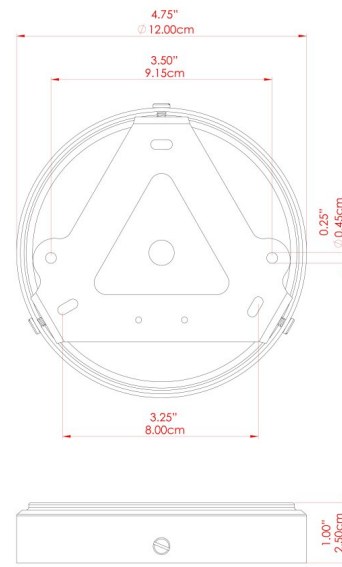

WWW.MULLANLIGHTING.COM

Product Notes:

1) Bulbs not included. 2) Dimensions do not include bulbs. 3) All products are individually made-to-order and therefore may differ slightly within manufacturing tolerances. 4) Cable / chain can be shortened during installation. Longer cable / chain lengths available on request. 5) Additional color finishes may be available on request. 6) Twisted cable is not available for UL wired products. Round cable in black or brown only is supplied instead. 7) Refer to our website for a full list of terms and conditions.





RIVALE Ceramic Pendant

MLCMP056POLBRSOP Polished Brass

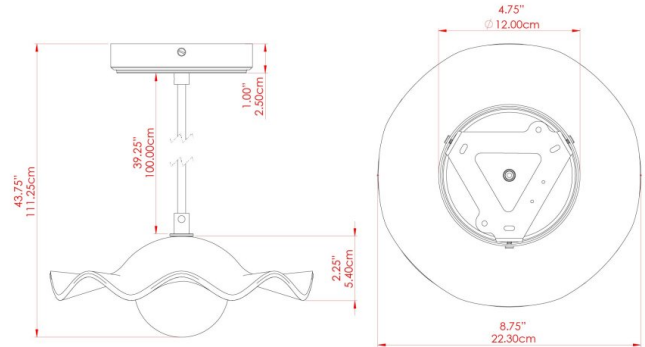

MATERIAL	Ceramic Brass Glass
HEIGHT	3.25"
WIDTH DIAMETER	8.25"
LENGTH PROJECTION	n/a
WEIGHT	0.6 kg 1.3 lbs
LAMPHOLDER	G9
MAX WATTAGE	6.5W
VOLTAGE	110/120v
ENVIRONMENTAL RATING	Dry Location (IP20)
CLASS PROTECTION	Class I
SHADE	GL192 MLCS063
FLEX BAR CHAIN LENGTH	40"
CABLE TYPE	MLCA028 Black Fabric Braided Cable 2 Core Round

FIXING BRACKET: MLWB17

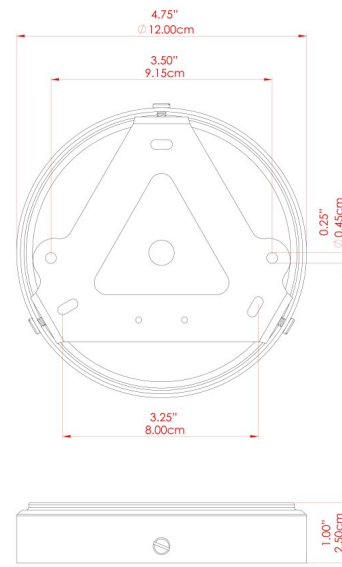

Product Notes:
 1) Bulbs not included. 2) Dimensions do not include bulbs. 3) All products are individually made-to-order and therefore may differ slightly within manufacturing tolerances. 4) Cable / chain can be shortened during installation. Longer cable / chain lengths available on request. 5) Additional color finishes may be available on request. 6) Twisted cable is not available for UL wired products. Round cable in black or brown only is supplied instead. 7) Refer to our website for a full list of terms and conditions.





RIVALE Ceramic Pendant

MLCMP056SATBRSOP Satin Brass

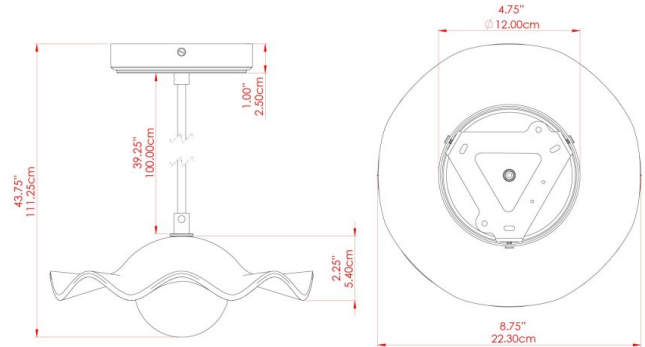

MATERIAL	Ceramic Brass Glass
HEIGHT	3.25"
WIDTH DIAMETER	8.25"
LENGTH PROJECTION	n/a
WEIGHT	0.6 kg 1.3 lbs
LAMPHOLDER	G9
MAX WATTAGE	6.5W
VOLTAGE	110/120v
ENVIRONMENTAL RATING	Dry Location (IP20)
CLASS PROTECTION	Class I
SHADE	GL192 MLCS063
FLEX BAR CHAIN LENGTH	40"
CABLE TYPE	MLCA028 Black Fabric Braided Cable 2 Core Round

FIXING BRACKET: MLWB17

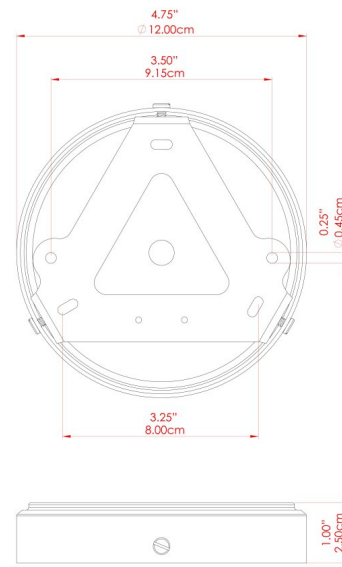

Product Notes:
1) Bulbs not included. 2) Dimensions do not include bulbs. 3) All products are individually made-to-order and therefore may differ slightly within manufacturing tolerances. 4) Cable / chain can be shortened during installation. Longer cable / chain lengths available on request. 5) Additional color finishes may be available on request. 6) Twisted cable is not available for UL wired products. Round cable in black or brown only is supplied instead. 7) Refer to our website for a full list of terms and conditions.





RIVALE Ceramic Pendant

MLCMP056PCMBKOP Matt Black

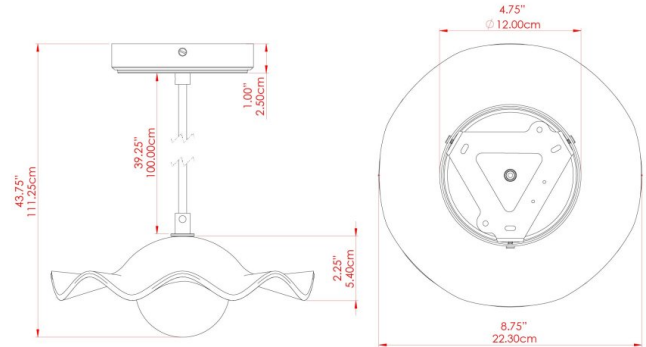

MATERIAL	Ceramic Brass
HEIGHT	3.25"
WIDTH DIAMETER	8.25"
LENGTH PROJECTION	n/a
WEIGHT	0.6 kg 1.3 lbs
LAMPHOLDER	G9
MAX WATTAGE	6.5W
VOLTAGE	110/120v
ENVIRONMENTAL RATING	Dry Location (IP20)
CLASS PROTECTION	Class I
SHADE	GL192 MLCS063
FLEX BAR CHAIN LENGTH	40"
CABLE TYPE	MLCA028 Black Fabric Braided Cable 2 Core Round

FIXING BRACKET: MLWB17

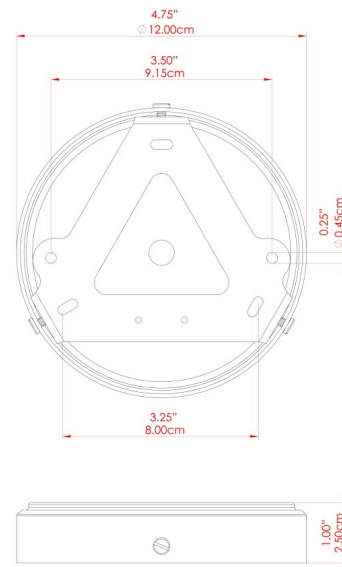

WWW.MULLANLIGHTING.COM

Product Notes:

1) Bulbs not included. 2) Dimensions do not include bulbs. 3) All products are individually made-to-order and therefore may differ slightly within manufacturing tolerances. 4) Cable / chain can be shortened during installation. Longer cable / chain lengths available on request. 5) Additional color finishes may be available on request. 6) Twisted cable is not available for UL wired products. Round cable in black or brown only is supplied instead. 7) Refer to our website for a full list of terms and conditions.





RIVALE Ceramic Pendant

MLCMP056ANTBRACL Antique Brass

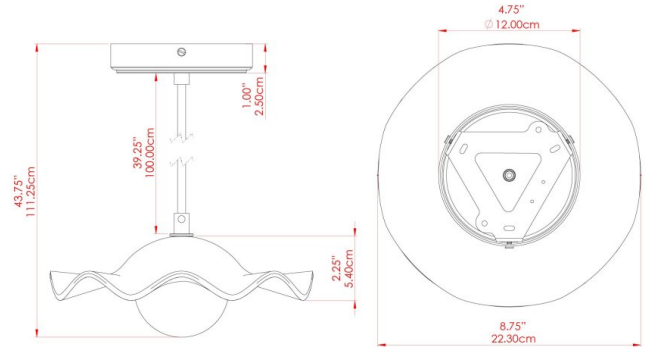

MATERIAL	Ceramic Brass Glass
HEIGHT	3.25"
WIDTH DIAMETER	8.25"
LENGTH PROJECTION	n/a
WEIGHT	0.6 kg 1.3 lbs
LAMPHOLDER	G9
MAX WATTAGE	6.5W
VOLTAGE	110/120v
ENVIRONMENTAL RATING	Dry Location (IP20)
CLASS PROTECTION	Class I
SHADE	GL196 MLCS063
FLEX BAR CHAIN LENGTH	40"
CABLE TYPE	MLCA047 Brown Fabric Braided Cable 2 Core Round

FIXING BRACKET: MLWB17

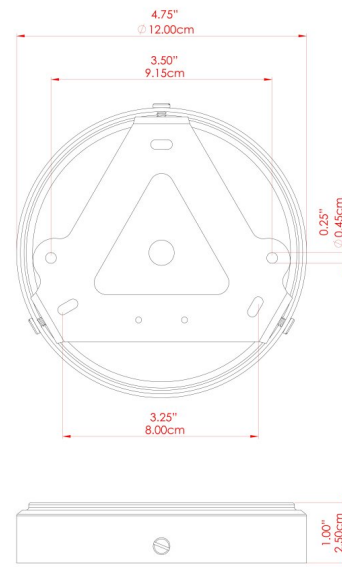

Product Notes:
1) Bulbs not included. 2) Dimensions do not include bulbs. 3) All products are individually made-to-order and therefore may differ slightly within manufacturing tolerances. 4) Cable / chain can be shortened during installation. Longer cable / chain lengths available on request. 5) Additional color finishes may be available on request. 6) Twisted cable is not available for UL wired products. Round cable in black or brown only is supplied instead. 7) Refer to our website for a full list of terms and conditions.





RIVALE Ceramic Pendant

MLCMP056ANTBRSFR Antique Brass

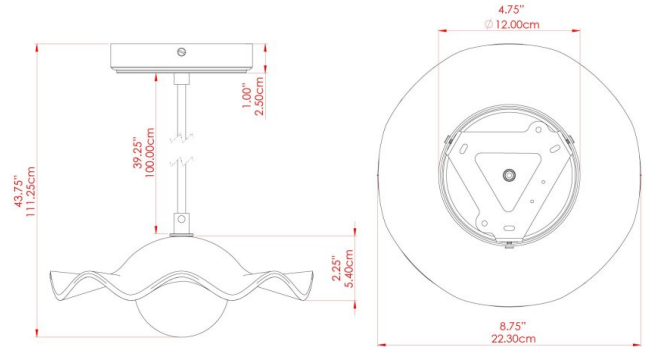

MATERIAL	Ceramic Brass Glass
HEIGHT	3.25"
WIDTH DIAMETER	8.25"
LENGTH PROJECTION	n/a
WEIGHT	0.6 kg 1.3 lbs
LAMPHOLDER	G9
MAX WATTAGE	6.5W
VOLTAGE	110/120v
ENVIRONMENTAL RATING	Dry Location (IP20)
CLASS PROTECTION	Class I
SHADE	GL208 MLCS063
FLEX BAR CHAIN LENGTH	40"
CABLE TYPE	MLCA047 Brown Fabric Braided Cable 2 Core Round

FIXING BRACKET: MLWB17

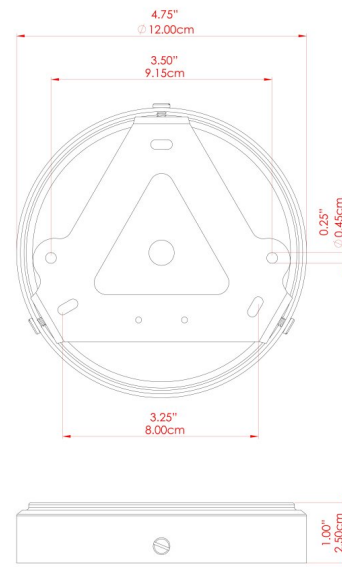

Product Notes:
1) Bulbs not included. 2) Dimensions do not include bulbs. 3) All products are individually made-to-order and therefore may differ slightly within manufacturing tolerances. 4) Cable / chain can be shortened during installation. Longer cable / chain lengths available on request. 5) Additional color finishes may be available on request. 6) Twisted cable is not available for UL wired products. Round cable in black or brown only is supplied instead. 7) Refer to our website for a full list of terms and conditions.





RIVALE Ceramic Pendant

MLCMP056ANTSLVCL Antique Silver

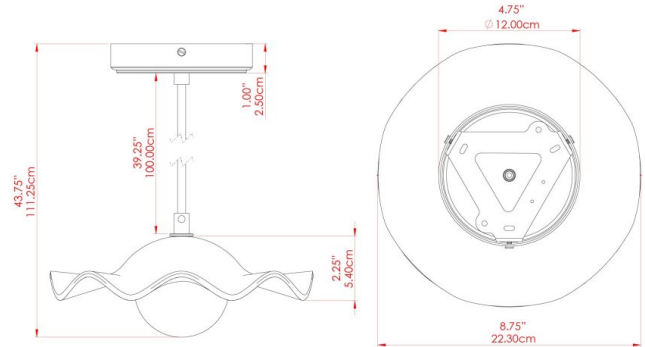

MATERIAL	Ceramic Brass Glass
HEIGHT	3.25"
WIDTH DIAMETER	8.25"
LENGTH PROJECTION	n/a
WEIGHT	0.6 kg 1.3 lbs
LAMPHOLDER	G9
MAX WATTAGE	6.5W
VOLTAGE	110/120v
ENVIRONMENTAL RATING	Dry Location (IP20)
CLASS PROTECTION	Class I
SHADE	GL196 MLCS063
FLEX BAR CHAIN LENGTH	40"
CABLE TYPE	MLCA028 Black Fabric Braided Cable 2 Core Round

FIXING BRACKET: MLWB17

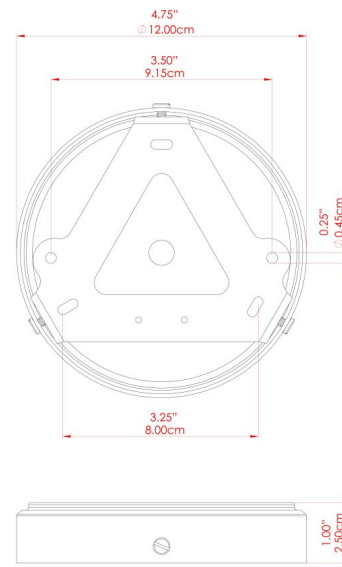

WWW.MULLANLIGHTING.COM

Product Notes:

1) Bulbs not included. 2) Dimensions do not include bulbs. 3) All products are individually made-to-order and therefore may differ slightly within manufacturing tolerances. 4) Cable / chain can be shortened during installation. Longer cable / chain lengths available on request. 5) Additional color finishes may be available on request. 6) Twisted cable is not available for UL wired products. Round cable in black or brown only is supplied instead. 7) Refer to our website for a full list of terms and conditions.





RIVALE Ceramic Pendant

MLCMP056PCMBKCL Matt Black



POWDER-COATED
MATTE BLACK

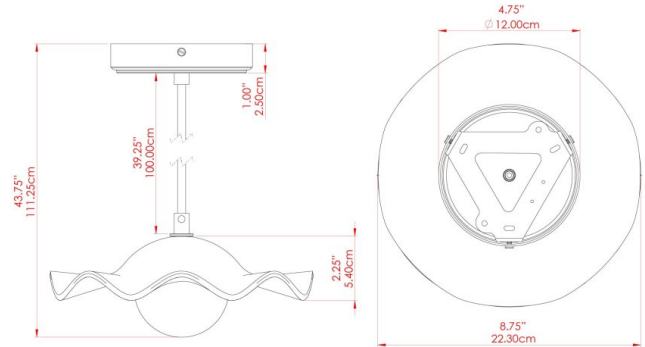

MATERIAL	Ceramic Brass
HEIGHT	3.25"
WIDTH DIAMETER	8.25"
LENGTH PROJECTION	n/a
WEIGHT	0.6 kg 1.3 lbs
LAMPHOLDER	G9
MAX WATTAGE	6.5W
VOLTAGE	110/120v
ENVIRONMENTAL RATING	Dry Location (IP20)
CLASS PROTECTION	Class I
SHADE	GL196 MLCS063
FLEX BAR CHAIN LENGTH	40"
CABLE TYPE	MLCA028 Black Fabric Braided Cable 2 Core Round

FIXING BRACKET: MLWB17

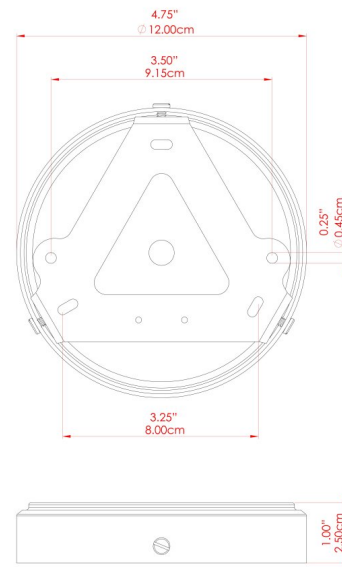

WWW.MULLANLIGHTING.COM

Product Notes:

1) Bulbs not included. 2) Dimensions do not include bulbs. 3) All products are individually made-to-order and therefore may differ slightly within manufacturing tolerances. 4) Cable / chain can be shortened during installation. Longer cable / chain lengths available on request. 5) Additional color finishes may be available on request. 6) Twisted cable is not available for UL wired products. Round cable in black or brown only is supplied instead. 7) Refer to our website for a full list of terms and conditions.





RIVALE Ceramic Pendant

MLCMP056PCMBKFR Matt Black

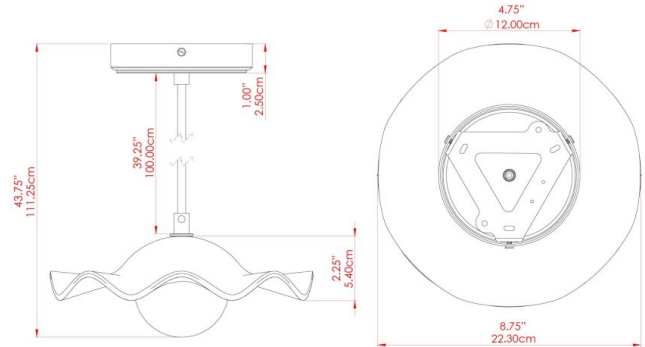

MATERIAL	Ceramic Brass
HEIGHT	3.25"
WIDTH DIAMETER	8.25"
LENGTH PROJECTION	n/a
WEIGHT	0.6 kg 1.3 lbs
LAMPHOLDER	G9
MAX WATTAGE	6.5W
VOLTAGE	110/120v
ENVIRONMENTAL RATING	Dry Location (IP20)
CLASS PROTECTION	Class I
SHADE	GL208 MLCS063
FLEX BAR CHAIN LENGTH	40"
CABLE TYPE	MLCA028 Black Fabric Braided Cable 2 Core Round

FIXING BRACKET: MLWB17

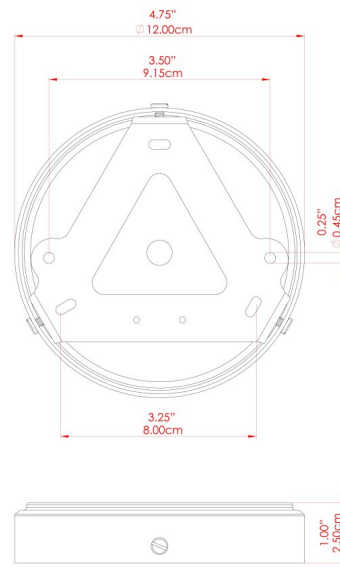

Product Notes:
 1) Bulbs not included. 2) Dimensions do not include bulbs. 3) All products are individually made-to-order and therefore may differ slightly within manufacturing tolerances. 4) Cable / chain can be shortened during installation. Longer cable / chain lengths available on request. 5) Additional color finishes may be available on request. 6) Twisted cable is not available for UL wired products. Round cable in black or brown only is supplied instead. 7) Refer to our website for a full list of terms and conditions.





RIVALE Ceramic Pendant

MLCMP056POLBRSCS Polished Brass

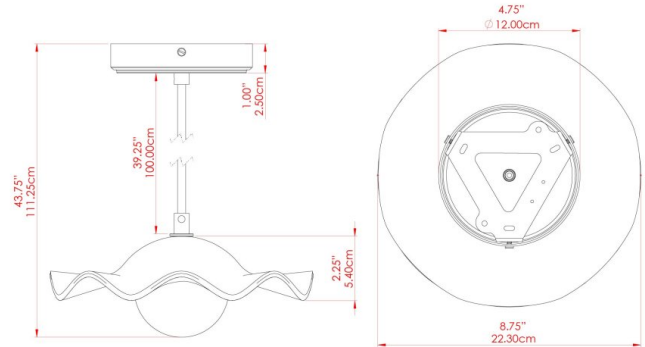

MATERIAL	Ceramic Brass Glass
HEIGHT	3.25"
WIDTH DIAMETER	8.25"
LENGTH PROJECTION	n/a
WEIGHT	0.6 kg 1.3 lbs
LAMPHOLDER	G9
MAX WATTAGE	6.5W
VOLTAGE	110/120v
ENVIRONMENTAL RATING	Dry Location (IP20)
CLASS PROTECTION	Class I
SHADE	GL196 MLCS063
FLEX BAR CHAIN LENGTH	40"
CABLE TYPE	MLCA028 Black Fabric Braided Cable 2 Core Round

FIXING BRACKET: MLWB17

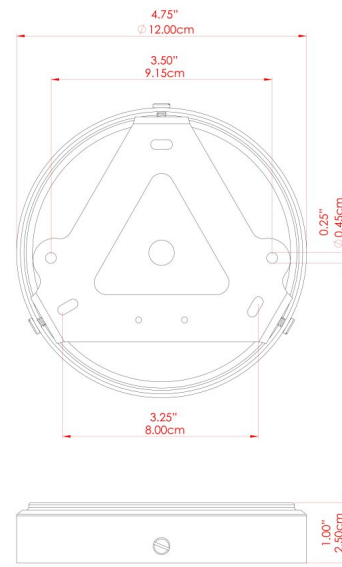

WWW.MULLANLIGHTING.COM

Product Notes:

1) Bulbs not included. 2) Dimensions do not include bulbs. 3) All products are individually made-to-order and therefore may differ slightly within manufacturing tolerances. 4) Cable / chain can be shortened during installation. Longer cable / chain lengths available on request. 5) Additional color finishes may be available on request. 6) Twisted cable is not available for UL wired products. Round cable in black or brown only is supplied instead. 7) Refer to our website for a full list of terms and conditions.





RIVALE Ceramic Pendant

MLCMP056POLBRSFR Polished Brass

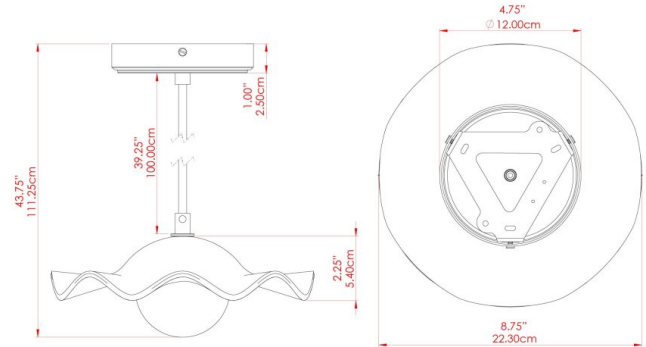

MATERIAL	Ceramic Brass Glass
HEIGHT	3.25"
WIDTH DIAMETER	8.25"
LENGTH PROJECTION	n/a
WEIGHT	0.6 kg 1.3 lbs
LAMPHOLDER	G9
MAX WATTAGE	6.5W
VOLTAGE	110/120v
ENVIRONMENTAL RATING	Dry Location (IP20)
CLASS PROTECTION	Class I
SHADE	GL208 MLCS063
FLEX BAR CHAIN LENGTH	40"
CABLE TYPE	MLCA028 Black Fabric Braided Cable 2 Core Round

FIXING BRACKET: MLWB17

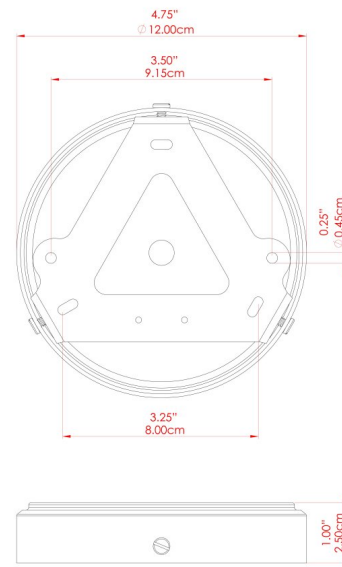

WWW.MULLANLIGHTING.COM

Product Notes:

1) Bulbs not included. 2) Dimensions do not include bulbs. 3) All products are individually made-to-order and therefore may differ slightly within manufacturing tolerances. 4) Cable / chain can be shortened during installation. Longer cable / chain lengths available on request. 5) Additional color finishes may be available on request. 6) Twisted cable is not available for UL wired products. Round cable in black or brown only is supplied instead. 7) Refer to our website for a full list of terms and conditions.





RIVALE Ceramic Pendant

MLCMP056SATBRSL Satin Brass

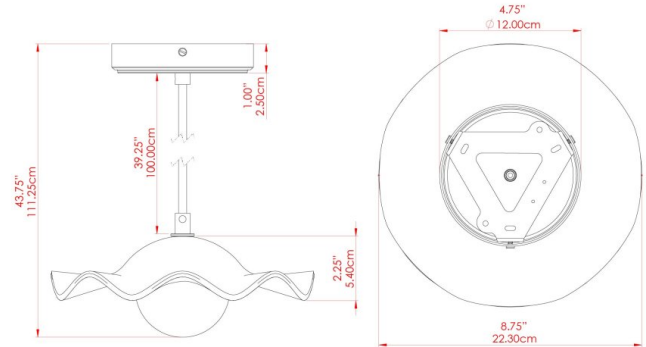

MATERIAL	Ceramic Brass Glass
HEIGHT	3.25"
WIDTH DIAMETER	8.25"
LENGTH PROJECTION	n/a
WEIGHT	0.6 kg 1.3 lbs
LAMPHOLDER	G9
MAX WATTAGE	6.5W
VOLTAGE	110/120v
ENVIRONMENTAL RATING	Dry Location (IP20)
CLASS PROTECTION	Class I
SHADE	GL196 MLCS063
FLEX BAR CHAIN LENGTH	40"
CABLE TYPE	MLCA028 Black Fabric Braided Cable 2 Core Round

FIXING BRACKET: MLWB17

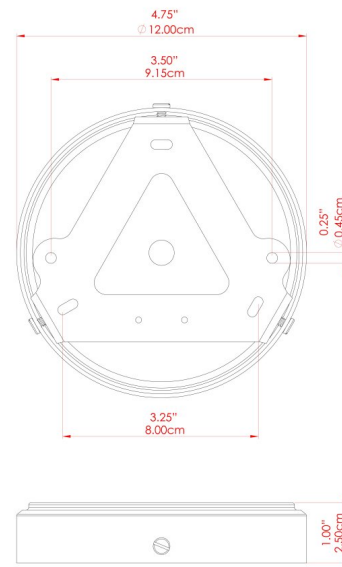

Product Notes:
1) Bulbs not included. 2) Dimensions do not include bulbs. 3) All products are individually made-to-order and therefore may differ slightly within manufacturing tolerances. 4) Cable / chain can be shortened during installation. Longer cable / chain lengths available on request. 5) Additional color finishes may be available on request. 6) Twisted cable is not available for UL wired products. Round cable in black or brown only is supplied instead. 7) Refer to our website for a full list of terms and conditions.





RIVALE Ceramic Pendant

MLCMP056SATBRSFR Satin Brass

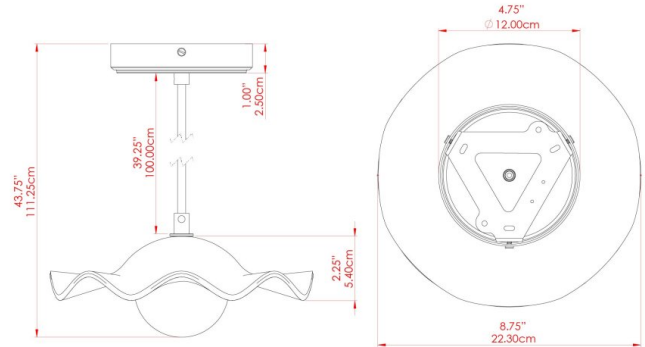

MATERIAL	Ceramic Brass Glass
HEIGHT	3.25"
WIDTH DIAMETER	8.25"
LENGTH PROJECTION	n/a
WEIGHT	0.6 kg 1.3 lbs
LAMPHOLDER	G9
MAX WATTAGE	6.5W
VOLTAGE	110/120v
ENVIRONMENTAL RATING	Dry Location (IP20)
CLASS PROTECTION	Class I
SHADE	GL208 MLCS063
FLEX BAR CHAIN LENGTH	40"
CABLE TYPE	MLCA028 Black Fabric Braided Cable 2 Core Round

FIXING BRACKET: MLWB17

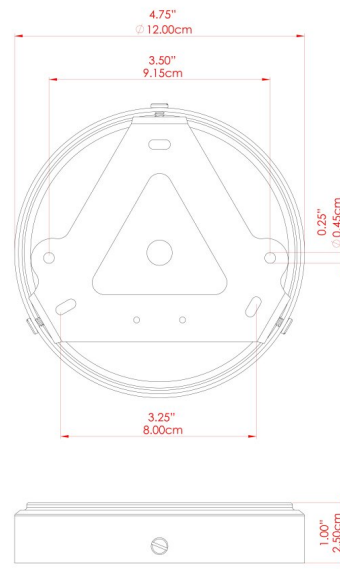

Product Notes:
 1) Bulbs not included. 2) Dimensions do not include bulbs. 3) All products are individually made-to-order and therefore may differ slightly within manufacturing tolerances. 4) Cable / chain can be shortened during installation. Longer cable / chain lengths available on request. 5) Additional color finishes may be available on request. 6) Twisted cable is not available for UL wired products. Round cable in black or brown only is supplied instead. 7) Refer to our website for a full list of terms and conditions.





RIVALE Ceramic Pendant

MLCMP056ANTSLVFR Antique Silver

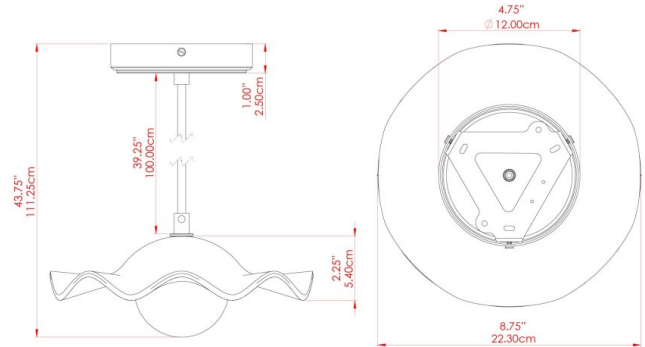

MATERIAL	Ceramic Brass Glass
HEIGHT	3.25"
WIDTH DIAMETER	8.25"
LENGTH PROJECTION	n/a
WEIGHT	0.6 kg 1.3 lbs
LAMPHOLDER	G9
MAX WATTAGE	6.5W
VOLTAGE	110/120v
ENVIRONMENTAL RATING	Dry Location (IP20)
CLASS PROTECTION	Class I
SHADE	GL208 MLCS063
FLEX BAR CHAIN LENGTH	40"
CABLE TYPE	MLCA028 Black Fabric Braided Cable 2 Core Round

FIXING BRACKET: MLWB17

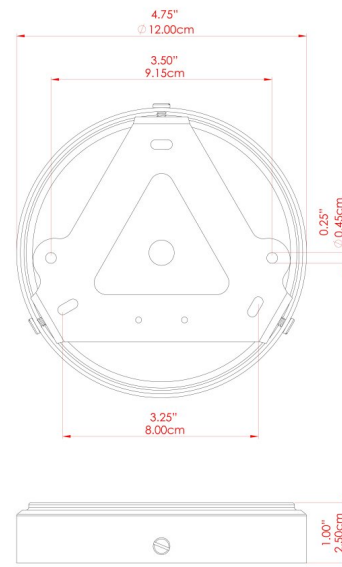

Product Notes:

1) Bulbs not included. 2) Dimensions do not include bulbs. 3) All products are individually made-to-order and therefore may differ slightly within manufacturing tolerances. 4) Cable / chain can be shortened during installation. Longer cable / chain lengths available on request. 5) Additional color finishes may be available on request. 6) Twisted cable is not available for UL wired products. Round cable in black or brown only is supplied instead. 7) Refer to our website for a full list of terms and conditions.

