

ELEGANCE Pendant

MLP327ANTBRS Antique Brass

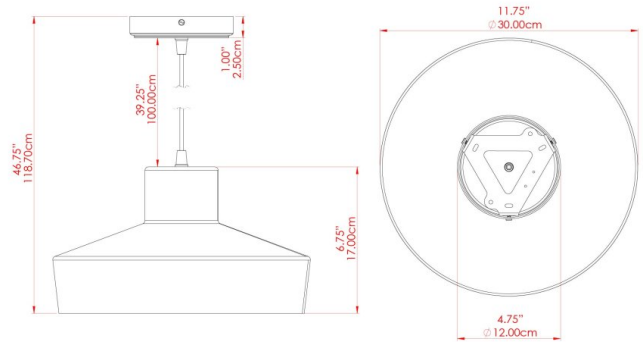

MATERIAL	Brass
HEIGHT	8.25"
WIDTH DIAMETER	12.5"
LENGTH PROJECTION	n/a
WEIGHT	1 kg 2.3 lbs
LAMPHOLDER	E26
MAX WATTAGE	40W
VOLTAGE	110/120v
ENVIRONMENTAL RATING	Dry Location (IP20)
CLASS PROTECTION	Class I
SHADE	-
FLEX BAR CHAIN LENGTH	40"
CABLE TYPE	MLCA002 Brown Fabric Braided Cable 2 Core Twisted

FIXING BRACKET: MLROSE39 | Antique Brass

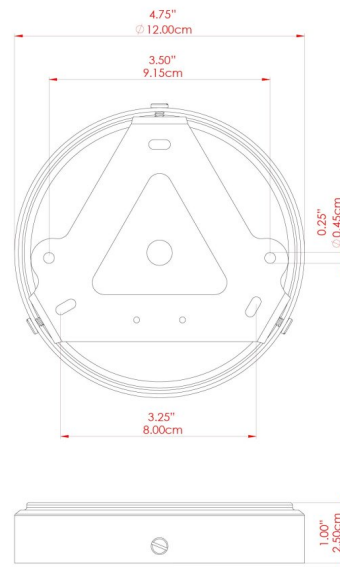

Product Notes:
 1) Bulbs not included. 2) Dimensions do not include bulbs. 3) All products are individually made-to-order and therefore may differ slightly within manufacturing tolerances. 4) Cable / chain can be shortened during installation. Longer cable / chain lengths available on request. 5) Additional color finishes may be available on request. 6) Twisted cable is not available for UL wired products. Round cable in black or brown only is supplied instead. 7) Refer to our website for a full list of terms and conditions.



ELEGANCE Pendant

MLP327ANTSLV Antique Silver

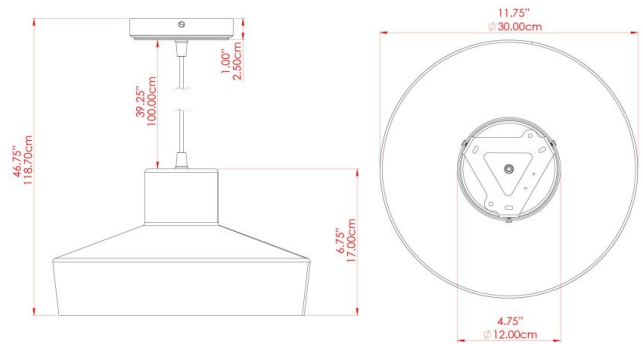

MATERIAL	Brass
HEIGHT	8.25"
WIDTH DIAMETER	12.5"
LENGTH PROJECTION	n/a
WEIGHT	1 kg 2.3 lbs
LAMPHOLDER	E26
MAX WATTAGE	40W
VOLTAGE	110/120v
ENVIRONMENTAL RATING	Dry Location (IP20)
CLASS PROTECTION	Class I
SHADE	-
FLEX BAR CHAIN LENGTH	40"
CABLE TYPE	MLCA001 Black Fabric Braided Cable 2 Core Twisted

FIXING BRACKET: MLROSE39 | Antique Silver

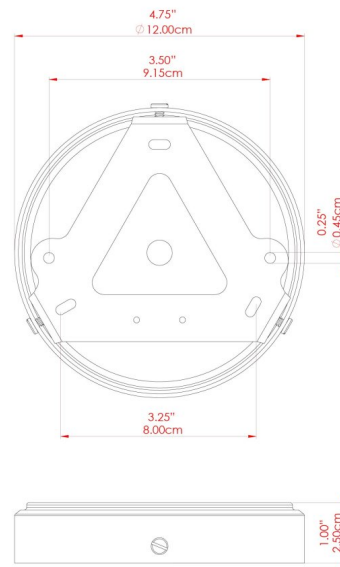

Product Notes:
 1) Bulbs not included. 2) Dimensions do not include bulbs. 3) All products are individually made-to-order and therefore may differ slightly within manufacturing tolerances. 4) Cable / chain can be shortened during installation. Longer cable / chain lengths available on request. 5) Additional color finishes may be available on request. 6) Twisted cable is not available for UL wired products. Round cable in black or brown only is supplied instead. 7) Refer to our website for a full list of terms and conditions.





ELEGANCE Pendant

MLP327POLBRS Polished Brass

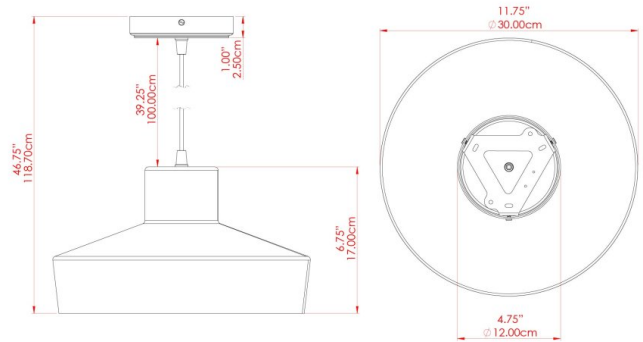

MATERIAL	Brass
HEIGHT	8.25"
WIDTH DIAMETER	12.5"
LENGTH PROJECTION	n/a
WEIGHT	1 kg 2.3 lbs
LAMPHOLDER	E26
MAX WATTAGE	40W
VOLTAGE	110/120v
ENVIRONMENTAL RATING	Dry Location (IP20)
CLASS PROTECTION	Class I
SHADE	-
FLEX BAR CHAIN LENGTH	40"
CABLE TYPE	MLCA001 Black Fabric Braided Cable 2 Core Twisted

FIXING BRACKET: MLROSE39 | Polished Brass

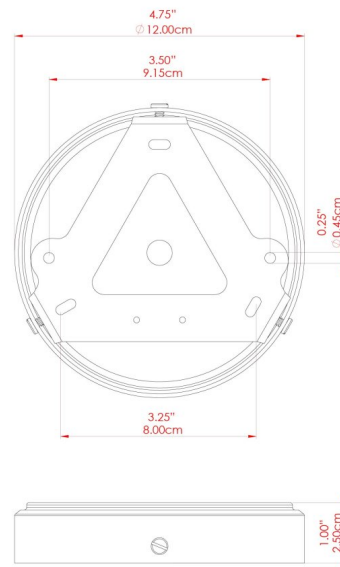

Product Notes:
 1) Bulbs not included. 2) Dimensions do not include bulbs. 3) All products are individually made-to-order and therefore may differ slightly within manufacturing tolerances. 4) Cable / chain can be shortened during installation. Longer cable / chain lengths available on request. 5) Additional color finishes may be available on request. 6) Twisted cable is not available for UL wired products. Round cable in black or brown only is supplied instead. 7) Refer to our website for a full list of terms and conditions.



ELEGANCE Pendant

MLP327SATBRS Satin Brass

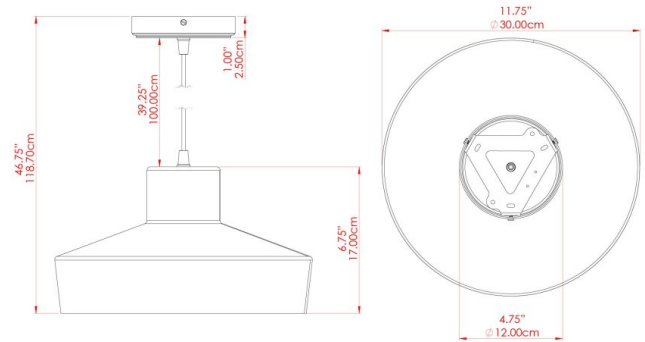

MATERIAL	Brass
HEIGHT	8.25"
WIDTH DIAMETER	12.5"
LENGTH PROJECTION	n/a
WEIGHT	1 kg 2.3 lbs
LAMPHOLDER	E26
MAX WATTAGE	40W
VOLTAGE	110/120v
ENVIRONMENTAL RATING	Dry Location (IP20)
CLASS PROTECTION	Class I
SHADE	-
FLEX BAR CHAIN LENGTH	40"
CABLE TYPE	MLCA001 Black Fabric Braided Cable 2 Core Twisted

FIXING BRACKET: MLROSE39 | Satin Brass

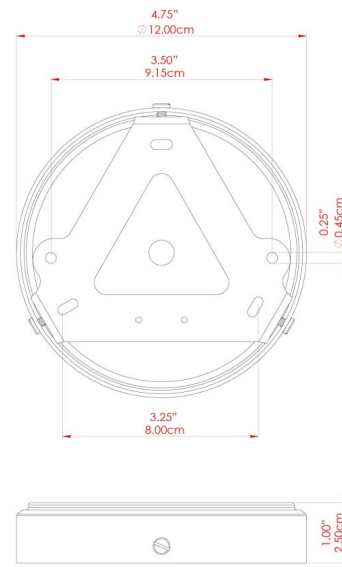

Product Notes:
 1) Bulbs not included. 2) Dimensions do not include bulbs. 3) All products are individually made-to-order and therefore may differ slightly within manufacturing tolerances. 4) Cable / chain can be shortened during installation. Longer cable / chain lengths available on request. 5) Additional color finishes may be available on request. 6) Twisted cable is not available for UL wired products. Round cable in black or brown only is supplied instead. 7) Refer to our website for a full list of terms and conditions.

