

TELAL Pendant

MLP193ANTBRS Antique Brass

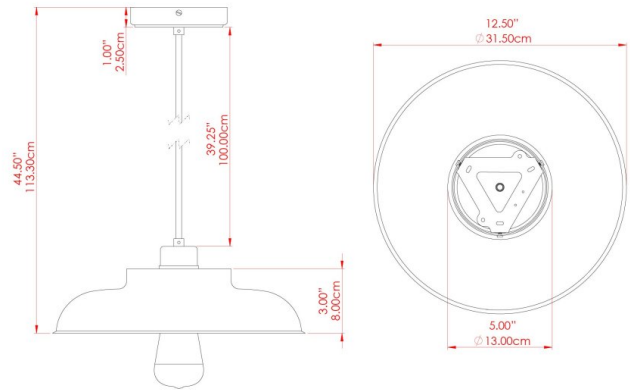

| | |
|---------------------------|---|
| MATERIAL | Brass |
| HEIGHT | 6.75" |
| WIDTH DIAMETER | 12.5" |
| LENGTH PROJECTION | n/a |
| WEIGHT | 0.72 kg 1.5 lbs |
| LAMPHOLDER | E26 |
| MAX WATTAGE | 40W |
| VOLTAGE | 110/120v |
| ENVIRONMENTAL RATING | Dry Location (IP20) |
| CLASS PROTECTION | Class I |
| SHADE | - |
| FLEX BAR CHAIN LENGTH | 40" |
| CABLE TYPE | MLCA002 Brown Fabric Braided Cable 2 Core Twisted |

FIXING BRACKET: MLROSE39 | Antique Brass

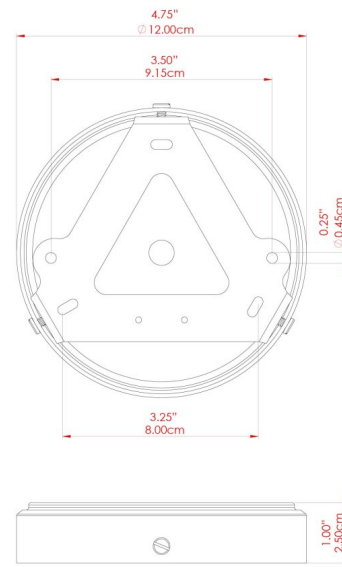

Product Notes:
 1) Bulbs not included. 2) Dimensions do not include bulbs. 3) All products are individually made-to-order and therefore may differ slightly within manufacturing tolerances. 4) Cable / chain can be shortened during installation. Longer cable / chain lengths available on request. 5) Additional color finishes may be available on request. 6) Twisted cable is not available for UL wired products. Round cable in black or brown only is supplied instead. 7) Refer to our website for a full list of terms and conditions.



TELAL Pendant

MLP193ANTSLV Antique Silver

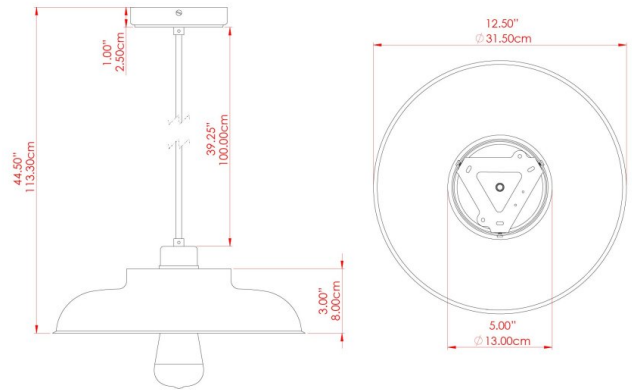

| | |
|---------------------------|---|
| MATERIAL | Brass |
| HEIGHT | 6.75" |
| WIDTH DIAMETER | 12.5" |
| LENGTH PROJECTION | n/a |
| WEIGHT | 0.72 kg 1.5 lbs |
| LAMPHOLDER | E26 |
| MAX WATTAGE | 40W |
| VOLTAGE | 110/120v |
| ENVIRONMENTAL RATING | Dry Location (IP20) |
| CLASS PROTECTION | Class I |
| SHADE | - |
| FLEX BAR CHAIN LENGTH | 40" |
| CABLE TYPE | MLCA001 Black Fabric Braided Cable 2 Core Twisted |

FIXING BRACKET: MLROSE39 | Antique Silver

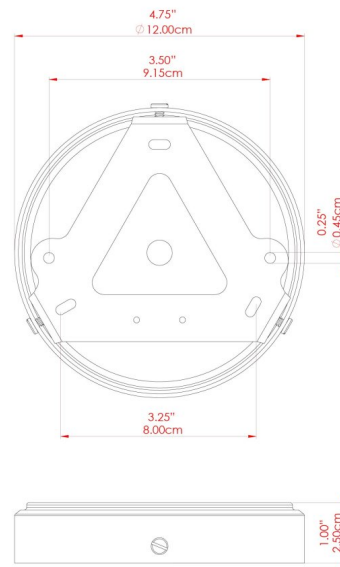

Product Notes:
 1) Bulbs not included. 2) Dimensions do not include bulbs. 3) All products are individually made-to-order and therefore may differ slightly within manufacturing tolerances. 4) Cable / chain can be shortened during installation. Longer cable / chain lengths available on request. 5) Additional color finishes may be available on request. 6) Twisted cable is not available for UL wired products. Round cable in black or brown only is supplied instead. 7) Refer to our website for a full list of terms and conditions.





TELAL Pendant

MLP193PCMBK Matt Black

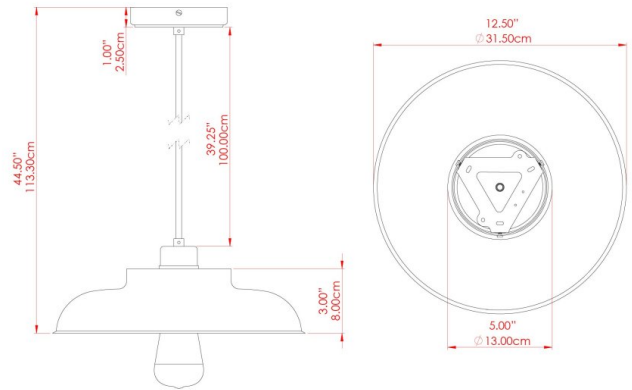

| | |
|---------------------------|---|
| MATERIAL | Brass Aluminium |
| HEIGHT | 6.75" |
| WIDTH DIAMETER | 12.5" |
| LENGTH PROJECTION | n/a |
| WEIGHT | 0.72 kg 1.5 lbs |
| LAMPHOLDER | E26 |
| MAX WATTAGE | 40W |
| VOLTAGE | 110/120v |
| ENVIRONMENTAL RATING | Dry Location (IP20) |
| CLASS PROTECTION | Class I |
| SHADE | |
| FLEX BAR CHAIN LENGTH | 40" |
| CABLE TYPE | MLCA001 Black Fabric Braided Cable 2 Core Twisted |

FIXING BRACKET: MLROSE39 | Matt Black

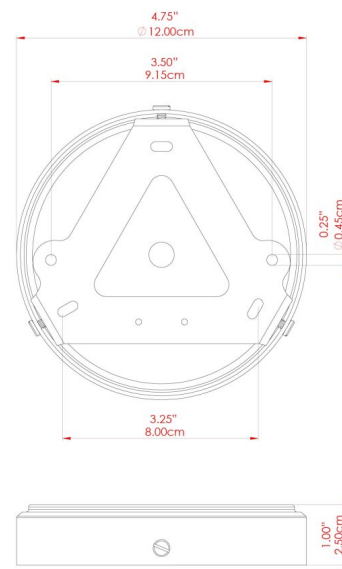

Product Notes:
1) Bulbs not included. 2) Dimensions do not include bulbs. 3) All products are individually made-to-order and therefore may differ slightly within manufacturing tolerances. 4) Cable / chain can be shortened during installation. Longer cable / chain lengths available on request. 5) Additional color finishes may be available on request. 6) Twisted cable is not available for UL wired products. Round cable in black or brown only is supplied instead. 7) Refer to our website for a full list of terms and conditions.





TELAL Pendant

MLP193POLBRS Polished Brass

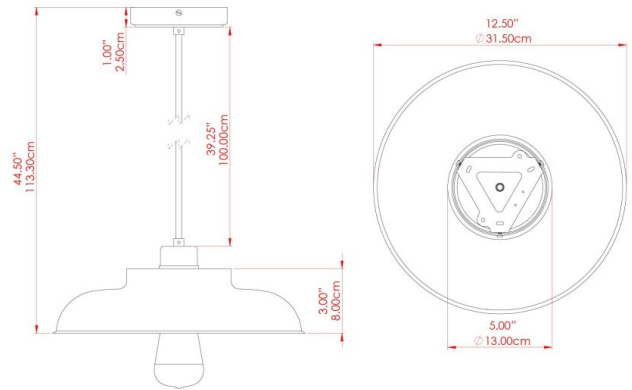

| | |
|---------------------------|---|
| MATERIAL | Brass |
| HEIGHT | 6.75" |
| WIDTH DIAMETER | 12.5" |
| LENGTH PROJECTION | n/a |
| WEIGHT | 0.72 kg 1.5 lbs |
| LAMPHOLDER | E26 |
| MAX WATTAGE | 40W |
| VOLTAGE | 110/120v |
| ENVIRONMENTAL RATING | Dry Location (IP20) |
| CLASS PROTECTION | Class I |
| SHADE | - |
| FLEX BAR CHAIN LENGTH | 40" |
| CABLE TYPE | MLCA001 Black Fabric Braided Cable 2 Core Twisted |

FIXING BRACKET: MLROSE39 | Polished Brass

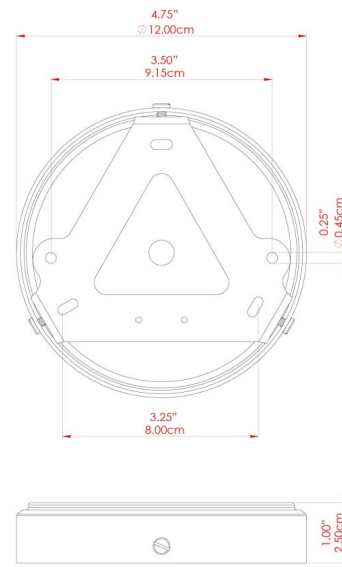

Product Notes:
 1) Bulbs not included. 2) Dimensions do not include bulbs. 3) All products are individually made-to-order and therefore may differ slightly within manufacturing tolerances. 4) Cable / chain can be shortened during installation. Longer cable / chain lengths available on request. 5) Additional color finishes may be available on request. 6) Twisted cable is not available for UL wired products. Round cable in black or brown only is supplied instead. 7) Refer to our website for a full list of terms and conditions.



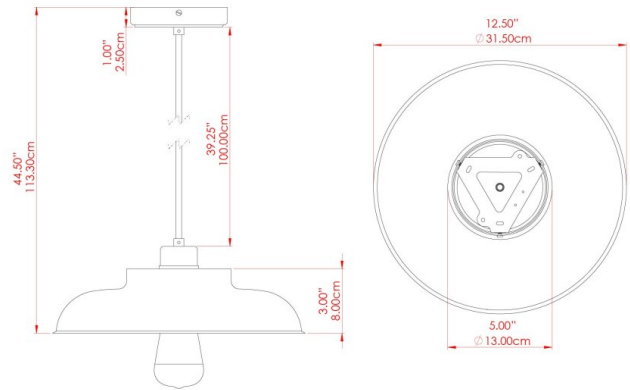

| | |
|---------------------------|---|
| MATERIAL | Brass |
| HEIGHT | 6.75" |
| WIDTH DIAMETER | 12.5" |
| LENGTH PROJECTION | n/a |
| WEIGHT | 0.72 kg 1.5 lbs |
| LAMPHOLDER | E26 |
| MAX WATTAGE | 40W |
| VOLTAGE | 110/120v |
| ENVIRONMENTAL RATING | Dry Location (IP20) |
| CLASS PROTECTION | Class I |
| SHADE | - |
| FLEX BAR CHAIN LENGTH | 40" |
| CABLE TYPE | MLCA001 Black Fabric Braided Cable 2 Core Twisted |

FIXING BRACKET: MLROSE39 | Satin Brass

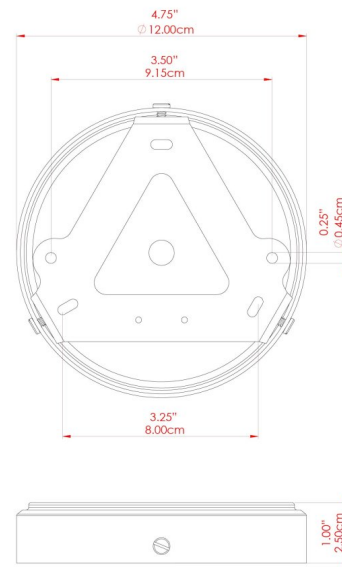

Product Notes:
 1) Bulbs not included. 2) Dimensions do not include bulbs. 3) All products are individually made-to-order and therefore may differ slightly within manufacturing tolerances. 4) Cable / chain can be shortened during installation. Longer cable / chain lengths available on request. 5) Additional color finishes may be available on request. 6) Twisted cable is not available for UL wired products. Round cable in black or brown only is supplied instead. 7) Refer to our website for a full list of terms and conditions.

