

HENLOW Pendant

MLP474ANTBRS Antique Brass

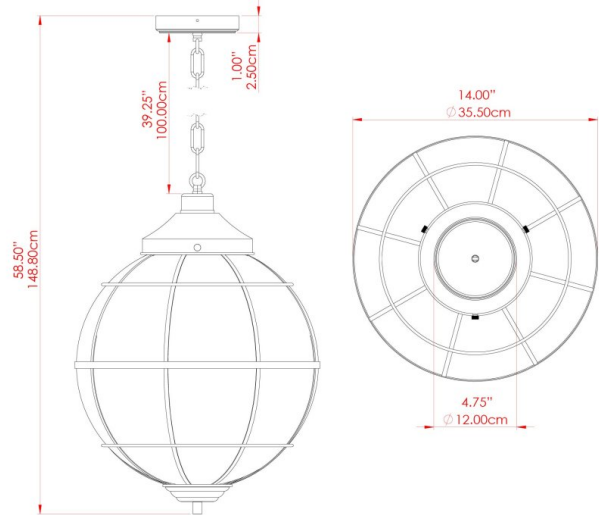

MATERIAL	Brass Glass
HEIGHT	19"
WIDTH DIAMETER	13.75"
LENGTH PROJECTION	n/a
WEIGHT	3.3 kg 7.3 lbs
LAMPHOLDER	E26
MAX WATTAGE	40W
VOLTAGE	110/120v
ENVIRONMENTAL RATING	Dry Location (IP20)
CLASS PROTECTION	Class I
SHADE	GL137
FLEX BAR CHAIN LENGTH	40"
CABLE TYPE	MLCA010 Brown PVC Flexible Cable 2 Core

FIXING BRACKET: MLWB17 | Antique Brass

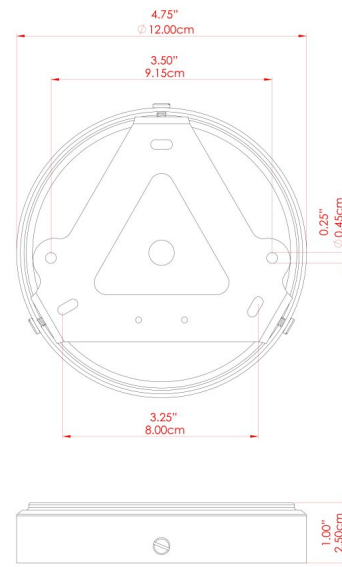

Product Notes:
 1) Bulbs not included. 2) Dimensions do not include bulbs. 3) All products are individually made-to-order and therefore may differ slightly within manufacturing tolerances. 4) Cable / chain can be shortened during installation. Longer cable / chain lengths available on request. 5) Additional color finishes may be available on request. 6) Twisted cable is not available for UL wired products. Round cable in black or brown only is supplied instead. 7) Refer to our website for a full list of terms and conditions.



HENLOW Pendant

MLP474NATBRS Natural Brass

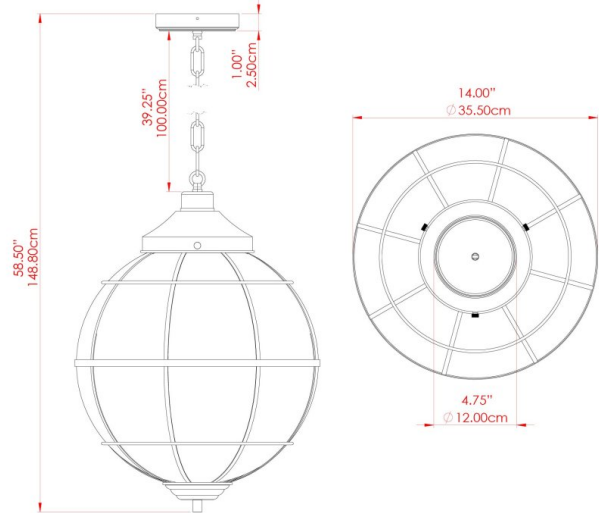

MATERIAL	Brass Glass
HEIGHT	19"
WIDTH DIAMETER	13.75"
LENGTH PROJECTION	n/a
WEIGHT	3.3 kg 7.3 lbs
LAMPHOLDER	E26
MAX WATTAGE	40W
VOLTAGE	110/120v
ENVIRONMENTAL RATING	Dry Location (IP20)
CLASS PROTECTION	Class I
SHADE	GL137
FLEX BAR CHAIN LENGTH	40"
CABLE TYPE	MLCA038 Gold PVC Flexible Cable 2 Core

FIXING BRACKET: MLWB17 | Natural Brass

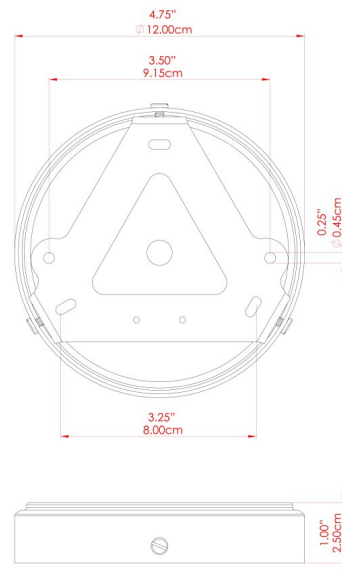

Product Notes:
 1) Bulbs not included. 2) Dimensions do not include bulbs. 3) All products are individually made-to-order and therefore may differ slightly within manufacturing tolerances. 4) Cable / chain can be shortened during installation. Longer cable / chain lengths available on request. 5) Additional color finishes may be available on request. 6) Twisted cable is not available for UL wired products. Round cable in black or brown only is supplied instead. 7) Refer to our website for a full list of terms and conditions.

