

# NOVA Pendant

## MLP256ANTBRS Antique Brass

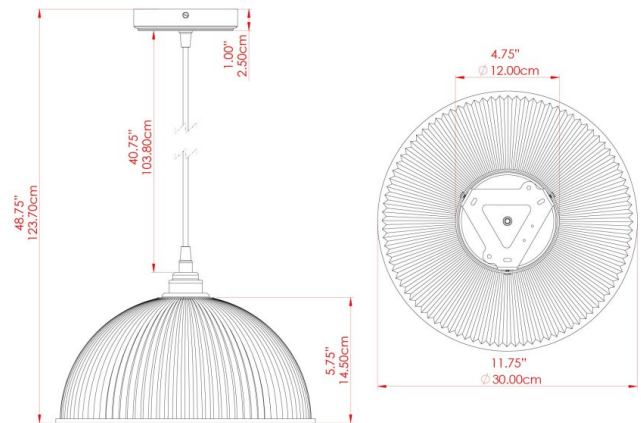

|                           |   |
|---------------------------|---|
| MATERIAL                  | Brass   Glass   |
| HEIGHT                    | 8.75"   |
| WIDTH   DIAMETER          | 11.75"  |
| LENGTH   PROJECTION       | n/a   |
| WEIGHT                    | 2.2 kg   4.8 lbs                                      |
| LAMPHOLDER                | E26   |
| MAX WATTAGE               | 40W   |
| VOLTAGE                   | 110/120v  |
| ENVIRONMENTAL RATING      | Dry Location (IP20)                                   |
| CLASS PROTECTION          | Class I   |
| SHADE                     | GL209   |
| FLEX   BAR   CHAIN LENGTH | 40"   |
| CABLE TYPE                | MLCA002   Brown Fabric Braided Cable   2 Core Twisted |

### FIXING BRACKET: MLROSE39 | Antique Brass

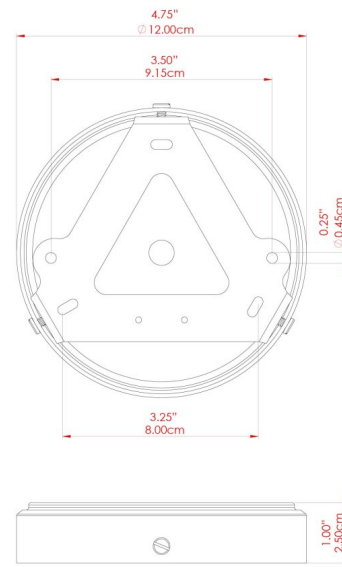

Product Notes:  
 1) Bulbs not included. 2) Dimensions do not include bulbs. 3) All products are individually made-to-order and therefore may differ slightly within manufacturing tolerances. 4) Cable / chain can be shortened during installation. Longer cable / chain lengths available on request. 5) Additional color finishes may be available on request. 6) Twisted cable is not available for UL wired products. Round cable in black or brown only is supplied instead. 7) Refer to our website for a full list of terms and conditions.



# NOVA Pendant

# MLP256ANTSLV Antique Silver

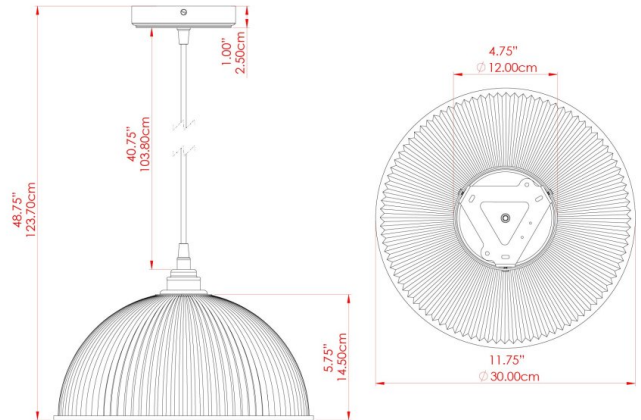

|                           |   |
|---------------------------|---|
| MATERIAL                  | Brass   Glass   |
| HEIGHT                    | 8.75"   |
| WIDTH   DIAMETER          | 11.75"  |
| LENGTH   PROJECTION       | n/a   |
| WEIGHT                    | 2.2 kg   4.8 lbs                                      |
| LAMPHOLDER                | E26   |
| MAX WATTAGE               | 40W   |
| VOLTAGE                   | 110/120v  |
| ENVIRONMENTAL RATING      | Dry Location (IP20)                                   |
| CLASS PROTECTION          | Class I   |
| SHADE                     | GL209   |
| FLEX   BAR   CHAIN LENGTH | 40"   |
| CABLE TYPE                | MLCA001   Black Fabric Braided Cable   2 Core Twisted |

### FIXING BRACKET: MLROSE39 | Antique Silver

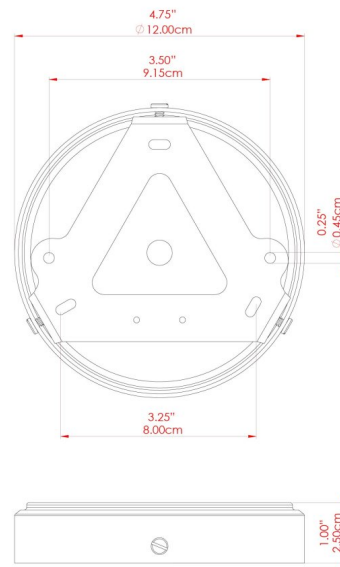

Product Notes:  
 1) Bulbs not included. 2) Dimensions do not include bulbs. 3) All products are individually made-to-order and therefore may differ slightly within manufacturing tolerances. 4) Cable / chain can be shortened during installation. Longer cable / chain lengths available on request. 5) Additional color finishes may be available on request. 6) Twisted cable is not available for UL wired products. Round cable in black or brown only is supplied instead. 7) Refer to our website for a full list of terms and conditions.



# NOVA Pendant

MLP256POLBRS Polished Brass

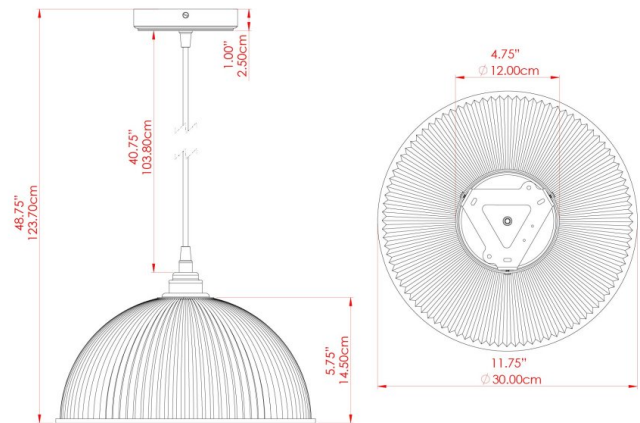

|                           |   |
|---------------------------|---|
| MATERIAL                  | Brass   Glass   |
| HEIGHT                    | 8.75"   |
| WIDTH   DIAMETER          | 11.75"  |
| LENGTH   PROJECTION       | n/a   |
| WEIGHT                    | 2.2 kg   4.8 lbs                                      |
| LAMPHOLDER                | E26   |
| MAX WATTAGE               | 40W   |
| VOLTAGE                   | 110/120v  |
| ENVIRONMENTAL RATING      | Dry Location (IP20)                                   |
| CLASS PROTECTION          | Class I   |
| SHADE                     | GL209   |
| FLEX   BAR   CHAIN LENGTH | 40"   |
| CABLE TYPE                | MLCA001   Black Fabric Braided Cable   2 Core Twisted |

## FIXING BRACKET: MLROSE39 | Polished Brass

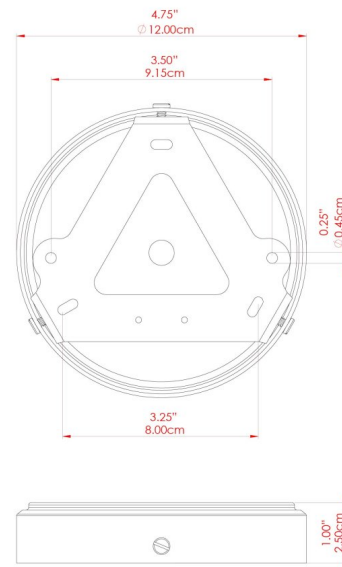

Product Notes:  
 1) Bulbs not included. 2) Dimensions do not include bulbs. 3) All products are individually made-to-order and therefore may differ slightly within manufacturing tolerances. 4) Cable / chain can be shortened during installation. Longer cable / chain lengths available on request. 5) Additional color finishes may be available on request. 6) Twisted cable is not available for UL wired products. Round cable in black or brown only is supplied instead. 7) Refer to our website for a full list of terms and conditions.





## NOVA Pendant

MLP256POLCHR Polished Chrome

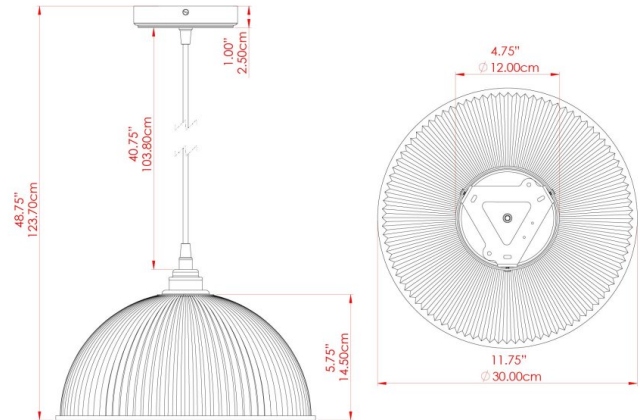

|                           |   |
|---------------------------|---|
| MATERIAL                  | Brass   Glass   |
| HEIGHT                    | 8.75"   |
| WIDTH   DIAMETER          | 11.75"  |
| LENGTH   PROJECTION       | n/a   |
| WEIGHT                    | 2.2 kg   4.8 lbs                                      |
| LAMPHOLDER                | E26   |
| MAX WATTAGE               | 40W   |
| VOLTAGE                   | 110/120v  |
| ENVIRONMENTAL RATING      | Dry Location (IP20)                                   |
| CLASS PROTECTION          | Class I   |
| SHADE                     | GL209   |
| FLEX   BAR   CHAIN LENGTH | 40"   |
| CABLE TYPE                | MLCA001   Black Fabric Braided Cable   2 Core Twisted |

FIXING BRACKET: MLROSE39 | Polished Chrome

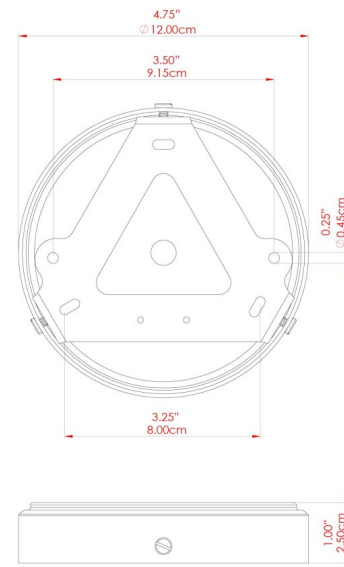

WWW.MULLANLIGHTING.COM

**Product Notes:**

1) Bulbs not included. 2) Dimensions do not include bulbs. 3) All products are individually made-to-order and therefore may differ slightly within manufacturing tolerances. 4) Cable / chain can be shortened during installation. Longer cable / chain lengths available on request. 5) Additional color finishes may be available on request. 6) Twisted cable is not available for UL wired products. Round cable in black or brown only is supplied instead. 7) Refer to our website for a full list of terms and conditions.





## NOVA Pendant

MLP256POLCOP Polished Copper

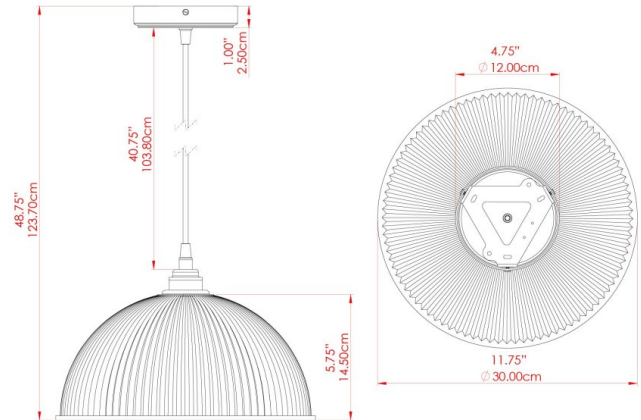

|                           |   |
|---------------------------|---|
| MATERIAL                  | Brass   Copper   Glass                                |
| HEIGHT                    | 8.75"   |
| WIDTH   DIAMETER          | 11.75"  |
| LENGTH   PROJECTION       | n/a   |
| WEIGHT                    | 2.2 kg   4.8 lbs                                      |
| LAMPHOLDER                | E26   |
| MAX WATTAGE               | 40W   |
| VOLTAGE                   | 110/120v  |
| ENVIRONMENTAL RATING      | Dry Location (IP20)                                   |
| CLASS PROTECTION          | Class I   |
| SHADE                     | GL209   |
| FLEX   BAR   CHAIN LENGTH | 40"   |
| CABLE TYPE                | MLCA001   Black Fabric Braided Cable   2 Core Twisted |

### FIXING BRACKET: MLROSE39 | Copper

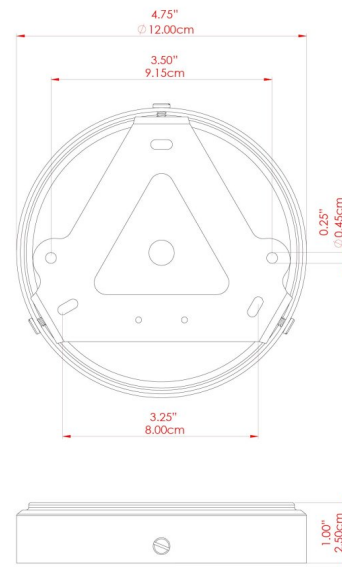

#### Product Notes:

1) Bulbs not included. 2) Dimensions do not include bulbs. 3) All products are individually made-to-order and therefore may differ slightly within manufacturing tolerances. 4) Cable / chain can be shortened during installation. Longer cable / chain lengths available on request. 5) Additional color finishes may be available on request. 6) Twisted cable is not available for UL wired products. Round cable in black or brown only is supplied instead. 7) Refer to our website for a full list of terms and conditions.



WWW.MULLANLIGHTING.COM





## NOVA Pendant

MLP256SATBRS Satin Brass

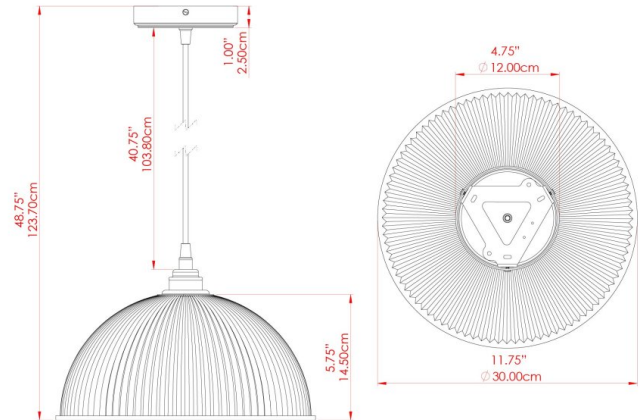

|                           |   |
|---------------------------|---|
| MATERIAL                  | Brass   Glass   |
| HEIGHT                    | 8.75"   |
| WIDTH   DIAMETER          | 11.75"  |
| LENGTH   PROJECTION       | n/a   |
| WEIGHT                    | 2.2 kg   4.8 lbs                                      |
| LAMPHOLDER                | E26   |
| MAX WATTAGE               | 40W   |
| VOLTAGE                   | 110/120v  |
| ENVIRONMENTAL RATING      | Dry Location (IP20)                                   |
| CLASS PROTECTION          | Class I   |
| SHADE                     | GL209   |
| FLEX   BAR   CHAIN LENGTH | 40"   |
| CABLE TYPE                | MLCA001   Black Fabric Braided Cable   2 Core Twisted |

FIXING BRACKET: MLROSE39 | Satin Brass

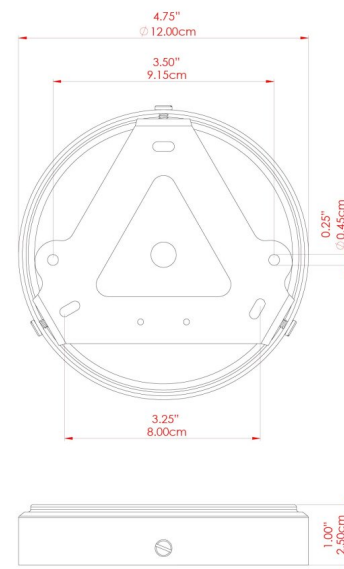

WWW.MULLANLIGHTING.COM

### Product Notes:

1) Bulbs not included. 2) Dimensions do not include bulbs. 3) All products are individually made-to-order and therefore may differ slightly within manufacturing tolerances. 4) Cable / chain can be shortened during installation. Longer cable / chain lengths available on request. 5) Additional color finishes may be available on request. 6) Twisted cable is not available for UL wired products. Round cable in black or brown only is supplied instead. 7) Refer to our website for a full list of terms and conditions.





# NOVA Pendant

MLP256SATCHR Satin Chrome

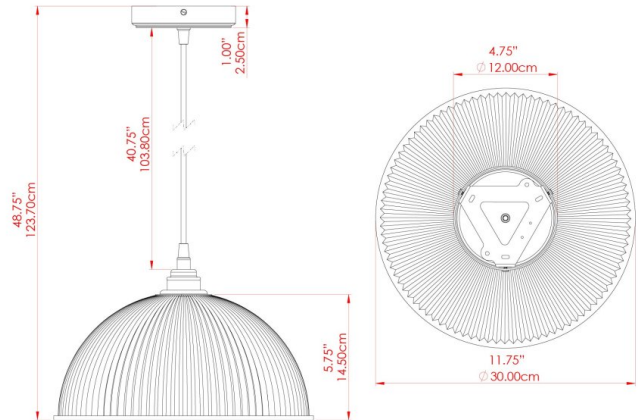

|                           |   |
|---------------------------|---|
| MATERIAL                  | Brass   Glass   |
| HEIGHT                    | 8.75"   |
| WIDTH   DIAMETER          | 11.75"  |
| LENGTH   PROJECTION       | n/a   |
| WEIGHT                    | 2.2 kg   4.8 lbs                                      |
| LAMPHOLDER                | E26   |
| MAX WATTAGE               | 40W   |
| VOLTAGE                   | 110/120v  |
| ENVIRONMENTAL RATING      | Dry Location (IP20)                                   |
| CLASS PROTECTION          | Class I   |
| SHADE                     | GL025   |
| FLEX   BAR   CHAIN LENGTH | 40"   |
| CABLE TYPE                | MLCA001   Black Fabric Braided Cable   2 Core Twisted |

### FIXING BRACKET: MLROSE39 | Satin Chrome

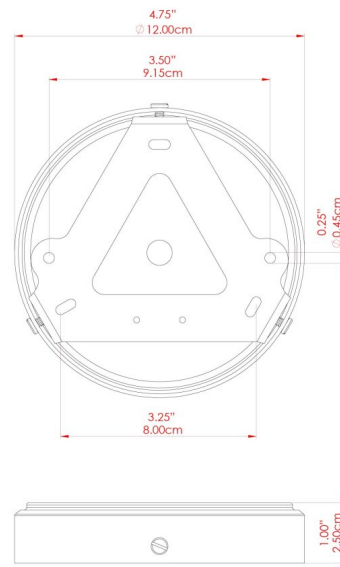

Product Notes:  
 1) Bulbs not included. 2) Dimensions do not include bulbs. 3) All products are individually made-to-order and therefore may differ slightly within manufacturing tolerances. 4) Cable / chain can be shortened during installation. Longer cable / chain lengths available on request. 5) Additional color finishes may be available on request. 6) Twisted cable is not available for UL wired products. Round cable in black or brown only is supplied instead. 7) Refer to our website for a full list of terms and conditions.

