

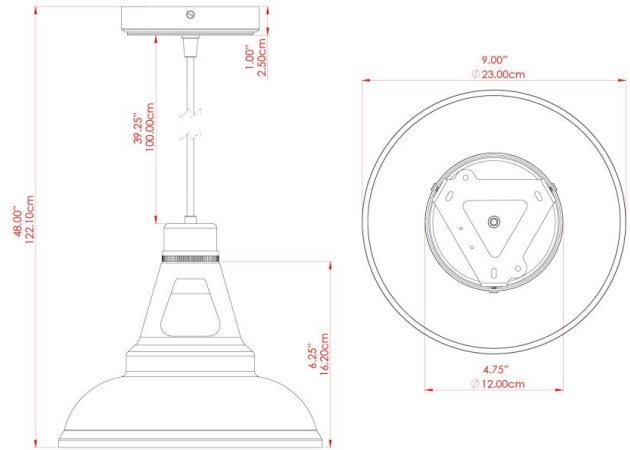

VIENNA Pendant

MLP372PCBLK Black



MATERIAL	Brass Steel
HEIGHT	8.25"
WIDTH DIAMETER	12"
LENGTH PROJECTION	n/a
WEIGHT	0.9 kg 2 lbs
LAMPHOLDER	E26
MAX WATTAGE	60W
VOLTAGE	110/120v
ENVIRONMENTAL RATING	Dry Location (IP20)
CLASS PROTECTION	Class I
SHADE	-
FLEX BAR CHAIN LENGTH	40"
CABLE TYPE	MLCA001 Black Fabric Braided Cable 2 Core Twisted

FIXING BRACKET: MLROSE39 | Black

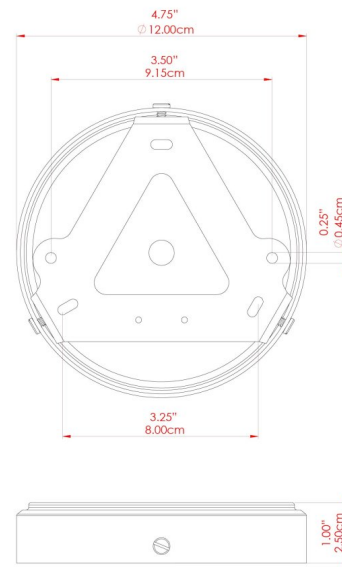

Product Notes:
 1) Bulbs not included. 2) Dimensions do not include bulbs. 3) All products are individually made-to-order and therefore may differ slightly within manufacturing tolerances. 4) Cable / chain can be shortened during installation. Longer cable / chain lengths available on request. 5) Additional color finishes may be available on request. 6) Twisted cable is not available for UL wired products. Round cable in black or brown only is supplied instead. 7) Refer to our website for a full list of terms and conditions.



VIENNA Pendant

MLP372PCBRZ Bronze

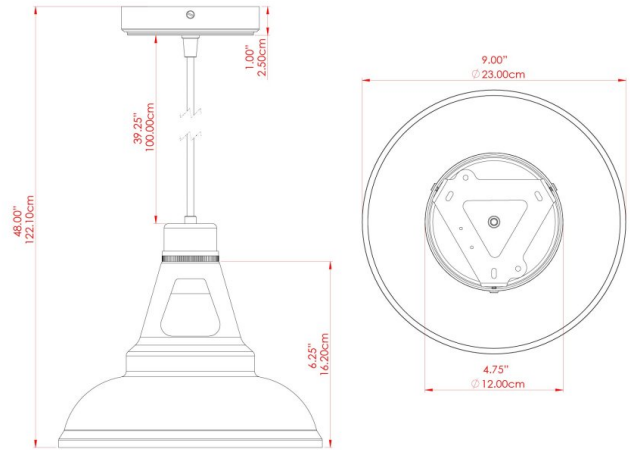

MATERIAL	Brass Steel
HEIGHT	8.25"
WIDTH DIAMETER	12"
LENGTH PROJECTION	n/a
WEIGHT	0.9 kg 2 lbs
LAMPHOLDER	E26
MAX WATTAGE	60W
VOLTAGE	110/120v
ENVIRONMENTAL RATING	Dry Location (IP20)
CLASS PROTECTION	Class I
SHADE	-
FLEX BAR CHAIN LENGTH	40"
CABLE TYPE	MLCA002 Brown Fabric Braided Cable 2 Core Twisted

FIXING BRACKET: MLROSE39 | Bronze

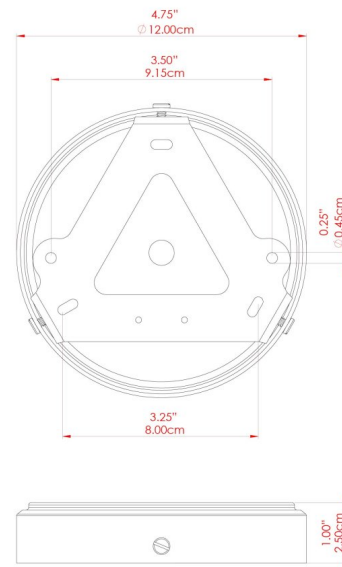

Product Notes:
 1) Bulbs not included. 2) Dimensions do not include bulbs. 3) All products are individually made-to-order and therefore may differ slightly within manufacturing tolerances. 4) Cable / chain can be shortened during installation. Longer cable / chain lengths available on request. 5) Additional color finishes may be available on request. 6) Twisted cable is not available for UL wired products. Round cable in black or brown only is supplied instead. 7) Refer to our website for a full list of terms and conditions.



VIENNA Pendant

MLP372PCGRN Sage Green

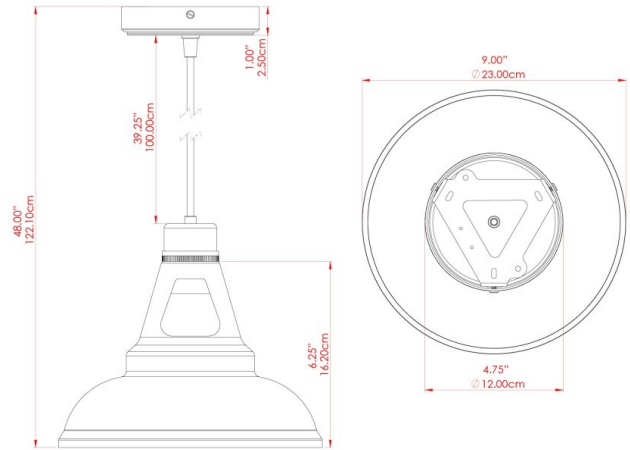

MATERIAL	Brass Steel
HEIGHT	8.25"
WIDTH DIAMETER	12"
LENGTH PROJECTION	n/a
WEIGHT	0.9 kg 2 lbs
LAMPHOLDER	E26
MAX WATTAGE	60W
VOLTAGE	110/120v
ENVIRONMENTAL RATING	Dry Location (IP20)
CLASS PROTECTION	Class I
SHADE	-
FLEX BAR CHAIN LENGTH	40"
CABLE TYPE	MLCA001 Black Fabric Braided Cable 2 Core Twisted

FIXING BRACKET: MLROSE39 | Green

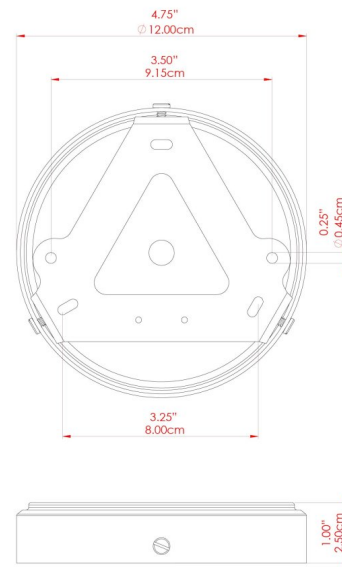

Product Notes:
 1) Bulbs not included. 2) Dimensions do not include bulbs. 3) All products are individually made-to-order and therefore may differ slightly within manufacturing tolerances. 4) Cable / chain can be shortened during installation. Longer cable / chain lengths available on request. 5) Additional color finishes may be available on request. 6) Twisted cable is not available for UL wired products. Round cable in black or brown only is supplied instead. 7) Refer to our website for a full list of terms and conditions.



VIENNA Pendant

MLP372PCGRY Grey

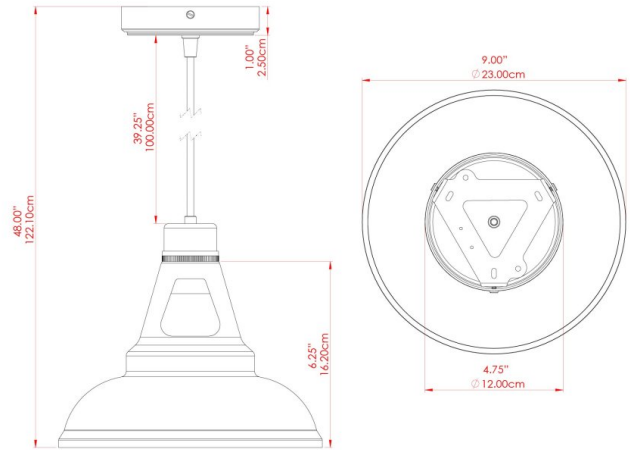

MATERIAL	Brass Steel
HEIGHT	8.25"
WIDTH DIAMETER	12"
LENGTH PROJECTION	n/a
WEIGHT	0.9 kg 2 lbs
LAMPHOLDER	E26
MAX WATTAGE	60W
VOLTAGE	110/120v
ENVIRONMENTAL RATING	Dry Location (IP20)
CLASS PROTECTION	Class I
SHADE	-
FLEX BAR CHAIN LENGTH	40"
CABLE TYPE	MLCA001 Black Fabric Braided Cable 2 Core Twisted

FIXING BRACKET: MLROSE39 | Grey

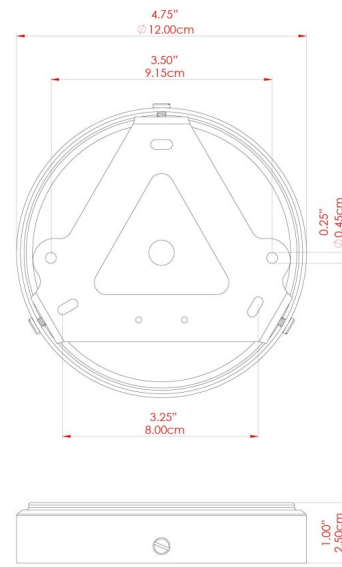

Product Notes:
 1) Bulbs not included. 2) Dimensions do not include bulbs. 3) All products are individually made-to-order and therefore may differ slightly within manufacturing tolerances. 4) Cable / chain can be shortened during installation. Longer cable / chain lengths available on request. 5) Additional color finishes may be available on request. 6) Twisted cable is not available for UL wired products. Round cable in black or brown only is supplied instead. 7) Refer to our website for a full list of terms and conditions.



VIENNA Pendant

MLP372PCMBK Matt Black

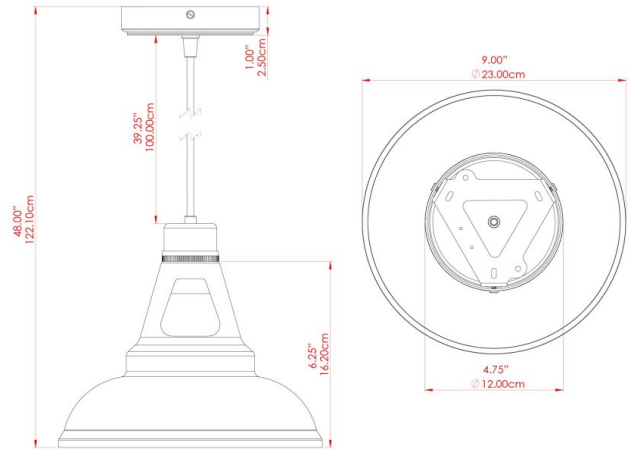

MATERIAL	Brass Steel
HEIGHT	8.25"
WIDTH DIAMETER	12"
LENGTH PROJECTION	n/a
WEIGHT	0.9 kg 2 lbs
LAMPHOLDER	E26
MAX WATTAGE	60W
VOLTAGE	110/120v
ENVIRONMENTAL RATING	Dry Location (IP20)
CLASS PROTECTION	Class I
SHADE	-
FLEX BAR CHAIN LENGTH	40"
CABLE TYPE	MLCA001 Black Fabric Braided Cable 2 Core Twisted

FIXING BRACKET: MLROSE39 | Matt Black

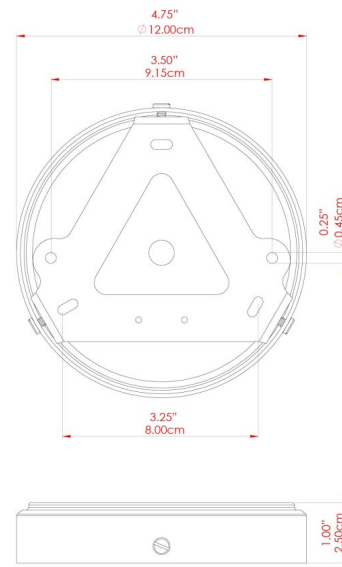

Product Notes:
 1) Bulbs not included. 2) Dimensions do not include bulbs. 3) All products are individually made-to-order and therefore may differ slightly within manufacturing tolerances. 4) Cable / chain can be shortened during installation. Longer cable / chain lengths available on request. 5) Additional color finishes may be available on request. 6) Twisted cable is not available for UL wired products. Round cable in black or brown only is supplied instead. 7) Refer to our website for a full list of terms and conditions.



VIENNA Pendant

MLP372PCORG Orange

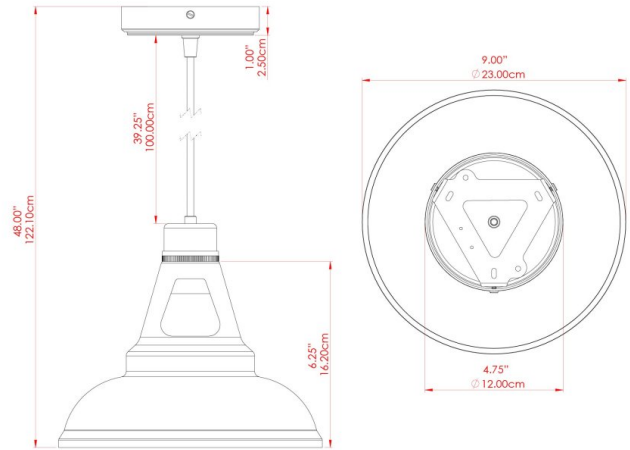

MATERIAL	Brass Steel
HEIGHT	8.25"
WIDTH DIAMETER	12"
LENGTH PROJECTION	n/a
WEIGHT	0.9 kg 2 lbs
LAMPHOLDER	E26
MAX WATTAGE	60W
VOLTAGE	110/120v
ENVIRONMENTAL RATING	Dry Location (IP20)
CLASS PROTECTION	Class I
SHADE	-
FLEX BAR CHAIN LENGTH	40"
CABLE TYPE	MLCA001 Black Fabric Braided Cable 2 Core Twisted

FIXING BRACKET: MLROSE39 | Orange

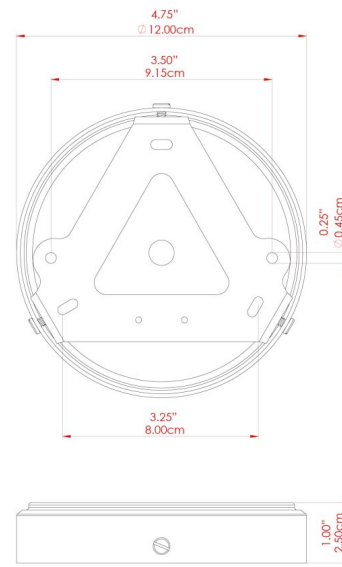

Product Notes:
 1) Bulbs not included. 2) Dimensions do not include bulbs. 3) All products are individually made-to-order and therefore may differ slightly within manufacturing tolerances. 4) Cable / chain can be shortened during installation. Longer cable / chain lengths available on request. 5) Additional color finishes may be available on request. 6) Twisted cable is not available for UL wired products. Round cable in black or brown only is supplied instead. 7) Refer to our website for a full list of terms and conditions.



VIENNA Pendant

MLP372PCRED Red

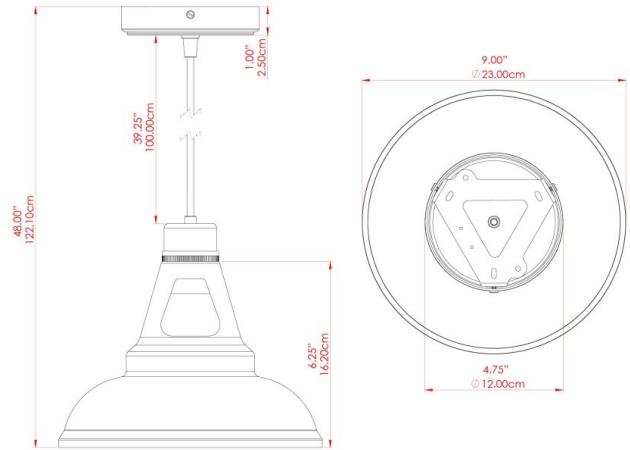

MATERIAL	Brass Steel
HEIGHT	8.25"
WIDTH DIAMETER	12"
LENGTH PROJECTION	n/a
WEIGHT	0.9 kg 2 lbs
LAMPHOLDER	E26
MAX WATTAGE	60W
VOLTAGE	110/120v
ENVIRONMENTAL RATING	Dry Location (IP20)
CLASS PROTECTION	Class I
SHADE	-
FLEX BAR CHAIN LENGTH	40"
CABLE TYPE	MLCA001 Black Fabric Braided Cable 2 Core Twisted

FIXING BRACKET: MLROSE39 | Red

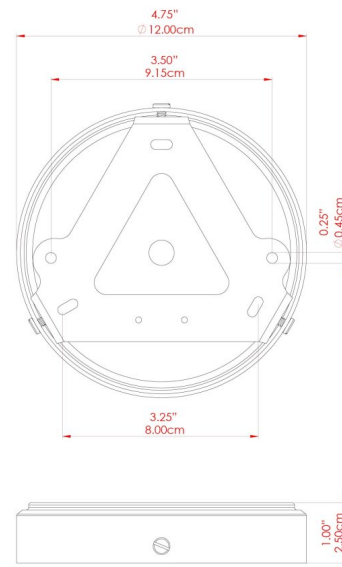

Product Notes:
 1) Bulbs not included. 2) Dimensions do not include bulbs. 3) All products are individually made-to-order and therefore may differ slightly within manufacturing tolerances. 4) Cable / chain can be shortened during installation. Longer cable / chain lengths available on request. 5) Additional color finishes may be available on request. 6) Twisted cable is not available for UL wired products. Round cable in black or brown only is supplied instead. 7) Refer to our website for a full list of terms and conditions.



VIENNA Pendant

MLP372PCRGR Racing Green

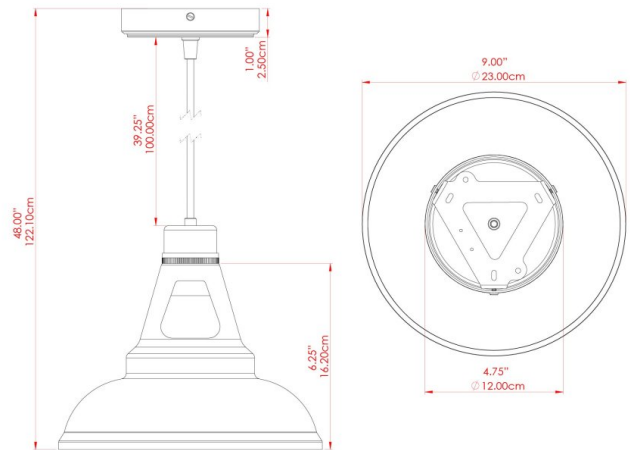

MATERIAL	Brass Steel
HEIGHT	8.25"
WIDTH DIAMETER	12"
LENGTH PROJECTION	n/a
WEIGHT	0.9 kg 2 lbs
LAMPHOLDER	E26
MAX WATTAGE	60W
VOLTAGE	110/120v
ENVIRONMENTAL RATING	Dry Location (IP20)
CLASS PROTECTION	Class I
SHADE	-
FLEX BAR CHAIN LENGTH	40"
CABLE TYPE	MLCA001 Black Fabric Braided Cable 2 Core Twisted

FIXING BRACKET: MLROSE39 | Racing Green

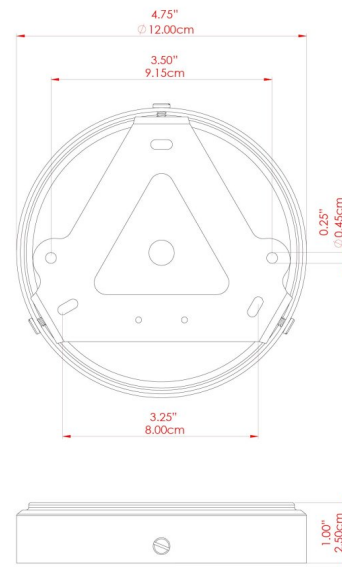

Product Notes:
 1) Bulbs not included. 2) Dimensions do not include bulbs. 3) All products are individually made-to-order and therefore may differ slightly within manufacturing tolerances. 4) Cable / chain can be shortened during installation. Longer cable / chain lengths available on request. 5) Additional color finishes may be available on request. 6) Twisted cable is not available for UL wired products. Round cable in black or brown only is supplied instead. 7) Refer to our website for a full list of terms and conditions.



VIENNA Pendant

MLP372PCWTE White

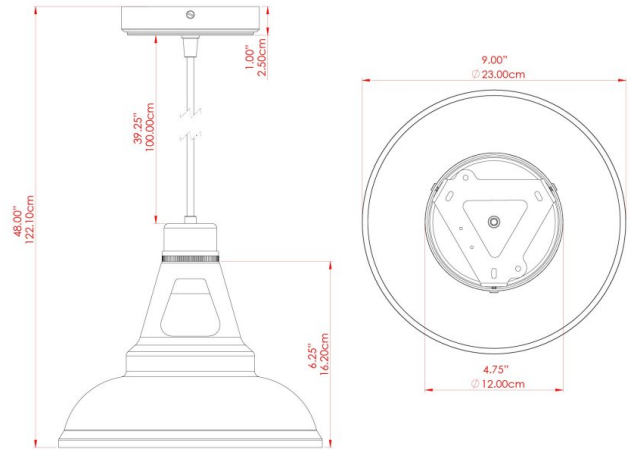

MATERIAL	Brass Steel
HEIGHT	8.25"
WIDTH DIAMETER	12"
LENGTH PROJECTION	n/a
WEIGHT	0.9 kg 2 lbs
LAMPHOLDER	E26
MAX WATTAGE	60W
VOLTAGE	110/120v
ENVIRONMENTAL RATING	Dry Location (IP20)
CLASS PROTECTION	Class I
SHADE	-
FLEX BAR CHAIN LENGTH	40"
CABLE TYPE	MLCA001 Black Fabric Braided Cable 2 Core Twisted

FIXING BRACKET: MLROSE39 | White

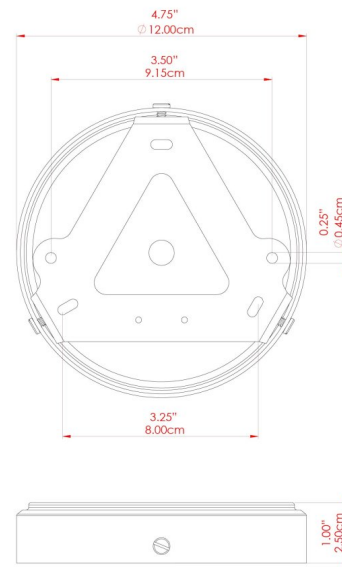

Product Notes:
 1) Bulbs not included. 2) Dimensions do not include bulbs. 3) All products are individually made-to-order and therefore may differ slightly within manufacturing tolerances. 4) Cable / chain can be shortened during installation. Longer cable / chain lengths available on request. 5) Additional color finishes may be available on request. 6) Twisted cable is not available for UL wired products. Round cable in black or brown only is supplied instead. 7) Refer to our website for a full list of terms and conditions.



VIENNA Pendant

MLP372PCYLW Yellow

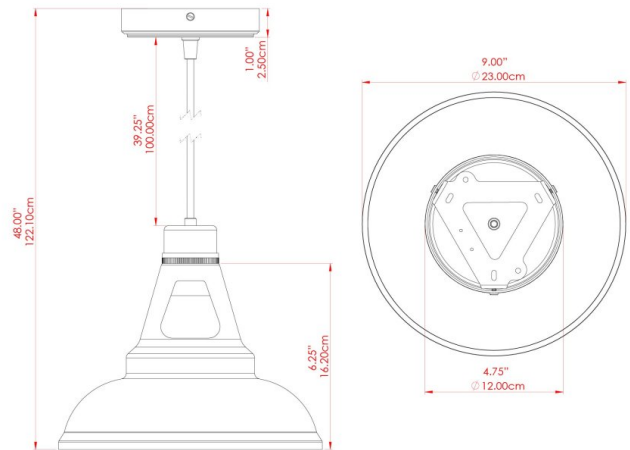

MATERIAL	Brass Steel
HEIGHT	8.25"
WIDTH DIAMETER	12"
LENGTH PROJECTION	n/a
WEIGHT	0.9 kg 2 lbs
LAMPHOLDER	E26
MAX WATTAGE	60W
VOLTAGE	110/120v
ENVIRONMENTAL RATING	Dry Location (IP20)
CLASS PROTECTION	Class I
SHADE	-
FLEX BAR CHAIN LENGTH	40"
CABLE TYPE	MLCA001 Black Fabric Braided Cable 2 Core Twisted

FIXING BRACKET: MLROSE39 | Yellow

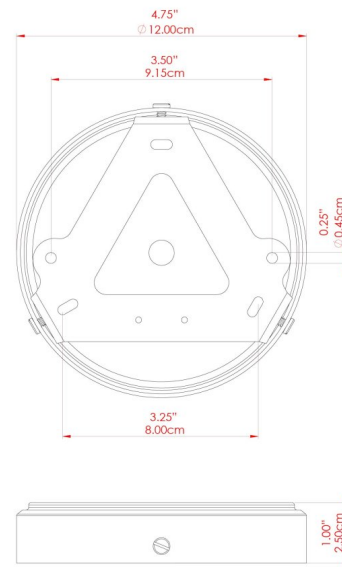

Product Notes:
 1) Bulbs not included. 2) Dimensions do not include bulbs. 3) All products are individually made-to-order and therefore may differ slightly within manufacturing tolerances. 4) Cable / chain can be shortened during installation. Longer cable / chain lengths available on request. 5) Additional color finishes may be available on request. 6) Twisted cable is not available for UL wired products. Round cable in black or brown only is supplied instead. 7) Refer to our website for a full list of terms and conditions.

