

# HELENA Pendant

## MLP460ANTBRSCS Antique Brass

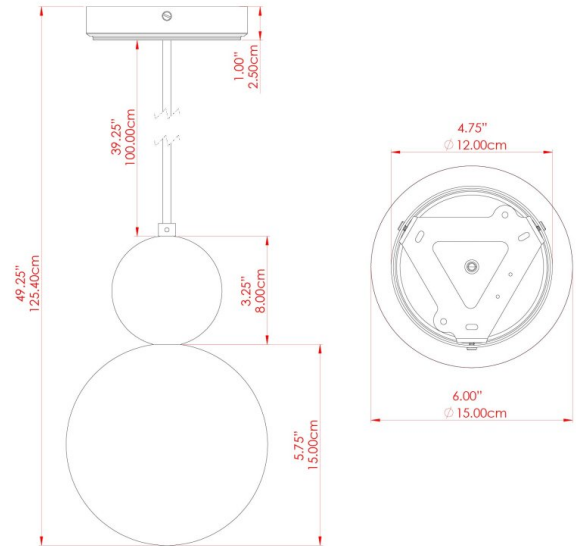

|                           |   |
|---------------------------|---|
| MATERIAL                  | Brass   Steel   Glass                                 |
| HEIGHT                    | 9.5"  |
| WIDTH   DIAMETER          | 6"  |
| LENGTH   PROJECTION       | n/a   |
| WEIGHT                    | 1 kg   2.3 lbs  |
| LAMPHOLDER                | G9  |
| MAX WATTAGE               | 6.5W  |
| VOLTAGE                   | 110/120v  |
| ENVIRONMENTAL RATING      | Dry Location (IP20)                                   |
| CLASS PROTECTION          | Class I   |
| SHADE                     | GL170   |
| FLEX   BAR   CHAIN LENGTH | 40"   |
| CABLE TYPE                | MLCA002   Brown Fabric Braided Cable   2 Core Twisted |

### FIXING BRACKET: MLWB17 | Antique Brass

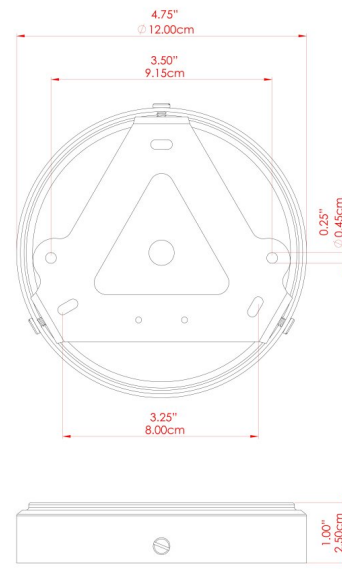

Product Notes:  
 1) Bulbs not included. 2) Dimensions do not include bulbs. 3) All products are individually made-to-order and therefore may differ slightly within manufacturing tolerances. 4) Cable / chain can be shortened during installation. Longer cable / chain lengths available on request. 5) Additional color finishes may be available on request. 6) Twisted cable is not available for UL wired products. Round cable in black or brown only is supplied instead. 7) Refer to our website for a full list of terms and conditions.



# HELENA Pendant

MLP460ANTBRSFR Antique Brass

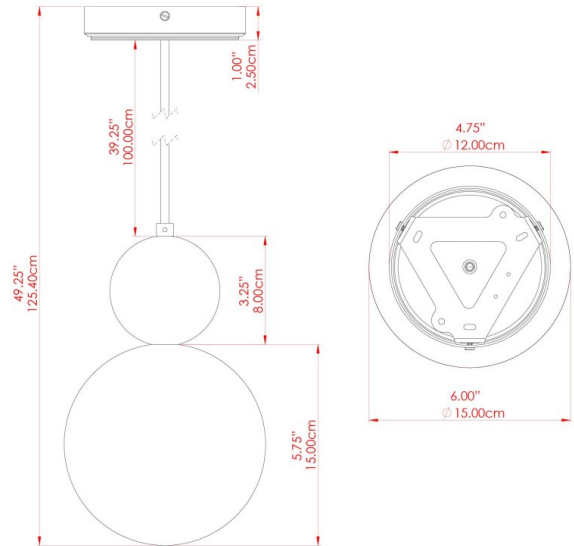

|                           |   |
|---------------------------|---|
| MATERIAL                  | Brass   Steel   Glass                                 |
| HEIGHT                    | 9.5"  |
| WIDTH   DIAMETER          | 6"  |
| LENGTH   PROJECTION       | n/a   |
| WEIGHT                    | 1 kg   2.3 lbs  |
| LAMPHOLDER                | G9  |
| MAX WATTAGE               | 6.5W  |
| VOLTAGE                   | 110/120v  |
| ENVIRONMENTAL RATING      | Dry Location (IP20)                                   |
| CLASS PROTECTION          | Class I   |
| SHADE                     | GL171   |
| FLEX   BAR   CHAIN LENGTH | 40"   |
| CABLE TYPE                | MLCA002   Brown Fabric Braided Cable   2 Core Twisted |

### FIXING BRACKET: MLWB17 | Antique Brass

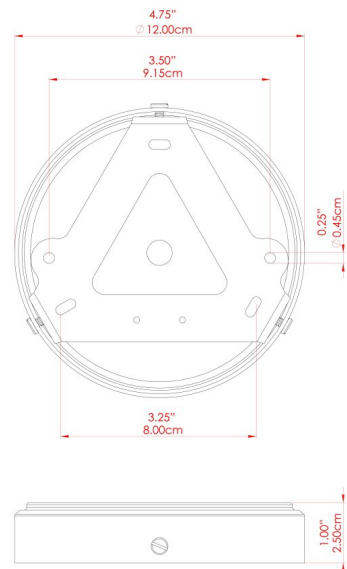

Product Notes:  
 1) Bulbs not included. 2) Dimensions do not include bulbs. 3) All products are individually made-to-order and therefore may differ slightly within manufacturing tolerances. 4) Cable / chain can be shortened during installation. Longer cable / chain lengths available on request. 5) Additional color finishes may be available on request. 6) Twisted cable is not available for UL wired products. Round cable in black or brown only is supplied instead. 7) Refer to our website for a full list of terms and conditions.



# HELENA Pendant

# MLP460ANTSLVCL Antique Silver

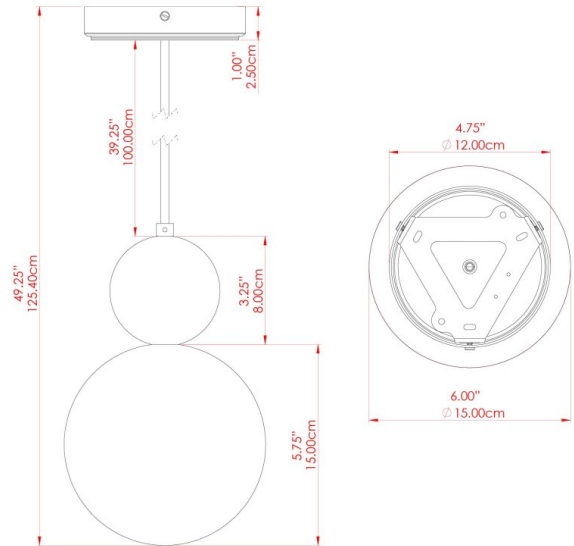

|                           |   |
|---------------------------|---|
| MATERIAL                  | Brass   Steel   Glass                                 |
| HEIGHT                    | 9.5"  |
| WIDTH   DIAMETER          | 6"  |
| LENGTH   PROJECTION       | n/a   |
| WEIGHT                    | 1 kg   2.3 lbs  |
| LAMPHOLDER                | G9  |
| MAX WATTAGE               | 6.5W  |
| VOLTAGE                   | 110/120v  |
| ENVIRONMENTAL RATING      | Dry Location (IP20)                                   |
| CLASS PROTECTION          | Class I   |
| SHADE                     | GL170   |
| FLEX   BAR   CHAIN LENGTH | 40"   |
| CABLE TYPE                | MLCA001   Black Fabric Braided Cable   2 Core Twisted |

### FIXING BRACKET: MLWB17 | Antique Silver

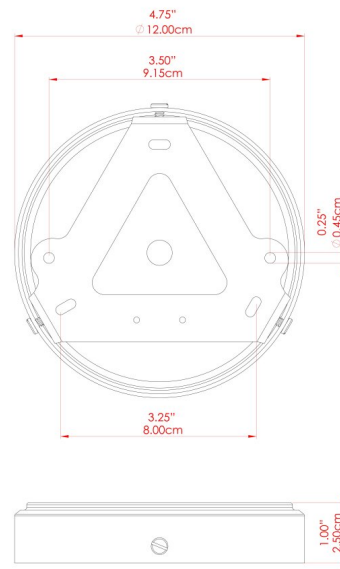

Product Notes:  
 1) Bulbs not included. 2) Dimensions do not include bulbs. 3) All products are individually made-to-order and therefore may differ slightly within manufacturing tolerances. 4) Cable / chain can be shortened during installation. Longer cable / chain lengths available on request. 5) Additional color finishes may be available on request. 6) Twisted cable is not available for UL wired products. Round cable in black or brown only is supplied instead. 7) Refer to our website for a full list of terms and conditions.



# HELENA Pendant

## MLP460ANTSLVFR Antique Silver

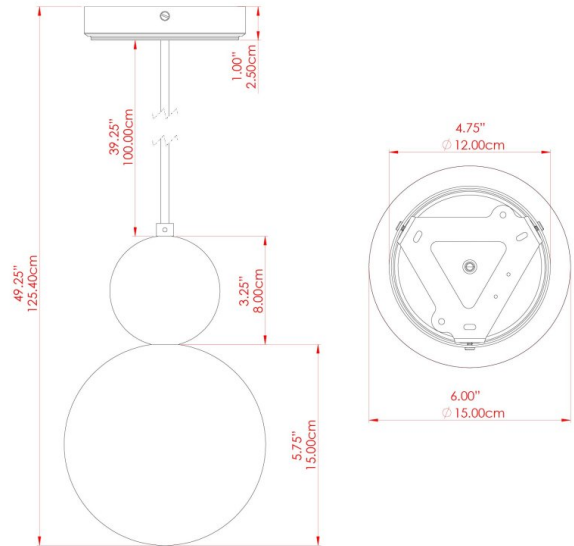

|                           |   |
|---------------------------|---|
| MATERIAL                  | Brass   Steel   Glass                                 |
| HEIGHT                    | 9.5"  |
| WIDTH   DIAMETER          | 6"  |
| LENGTH   PROJECTION       | n/a   |
| WEIGHT                    | 1 kg   2.3 lbs  |
| LAMPHOLDER                | G9  |
| MAX WATTAGE               | 6.5W  |
| VOLTAGE                   | 110/120v  |
| ENVIRONMENTAL RATING      | Dry Location (IP20)                                   |
| CLASS PROTECTION          | Class I   |
| SHADE                     | GL171   |
| FLEX   BAR   CHAIN LENGTH | 40"   |
| CABLE TYPE                | MLCA001   Black Fabric Braided Cable   2 Core Twisted |

### FIXING BRACKET: MLWB17 | Antique Silver

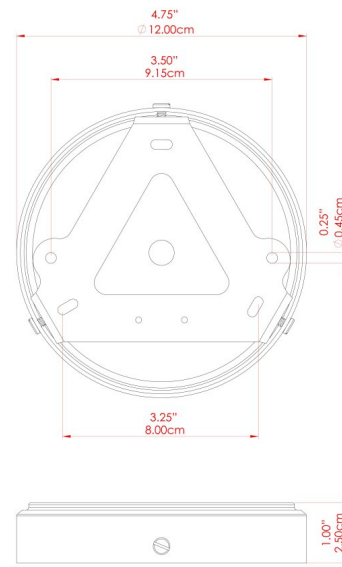

Product Notes:  
 1) Bulbs not included. 2) Dimensions do not include bulbs. 3) All products are individually made-to-order and therefore may differ slightly within manufacturing tolerances. 4) Cable / chain can be shortened during installation. Longer cable / chain lengths available on request. 5) Additional color finishes may be available on request. 6) Twisted cable is not available for UL wired products. Round cable in black or brown only is supplied instead. 7) Refer to our website for a full list of terms and conditions.



# HELENA Pendant

## MLP460POLBRSCS Polished Brass

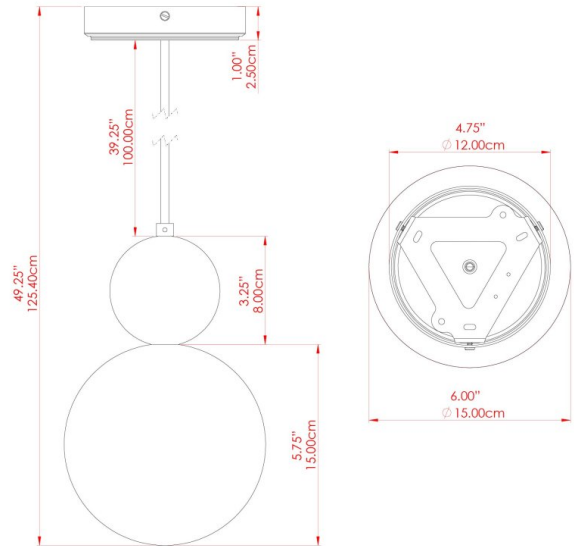

|                           |   |
|---------------------------|---|
| MATERIAL                  | Brass   Steel   Glass                                 |
| HEIGHT                    | 9.5"  |
| WIDTH   DIAMETER          | 6"  |
| LENGTH   PROJECTION       | n/a   |
| WEIGHT                    | 1 kg   2.3 lbs  |
| LAMPHOLDER                | G9  |
| MAX WATTAGE               | 6.5W  |
| VOLTAGE                   | 110/120v  |
| ENVIRONMENTAL RATING      | Dry Location (IP20)                                   |
| CLASS PROTECTION          | Class I   |
| SHADE                     | GL170   |
| FLEX   BAR   CHAIN LENGTH | 40"   |
| CABLE TYPE                | MLCA001   Black Fabric Braided Cable   2 Core Twisted |

### FIXING BRACKET: MLWB17 | Polished Brass

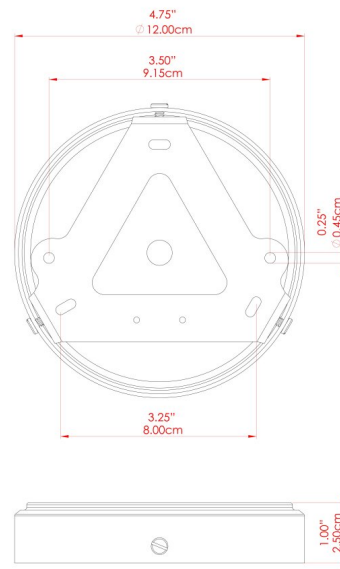

Product Notes:  
 1) Bulbs not included. 2) Dimensions do not include bulbs. 3) All products are individually made-to-order and therefore may differ slightly within manufacturing tolerances. 4) Cable / chain can be shortened during installation. Longer cable / chain lengths available on request. 5) Additional color finishes may be available on request. 6) Twisted cable is not available for UL wired products. Round cable in black or brown only is supplied instead. 7) Refer to our website for a full list of terms and conditions.



# HELENA Pendant

## MLP460POLBRSFR Polished Brass

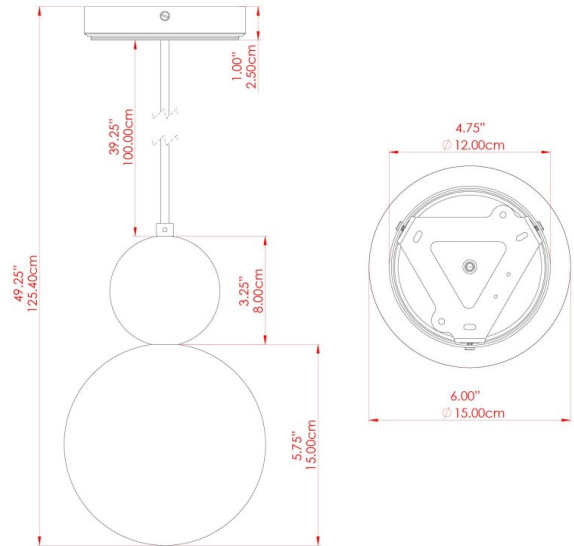

|                           |   |
|---------------------------|---|
| MATERIAL                  | Brass   Steel   Glass                                 |
| HEIGHT                    | 9.5"  |
| WIDTH   DIAMETER          | 6"  |
| LENGTH   PROJECTION       | n/a   |
| WEIGHT                    | 1 kg   2.3 lbs  |
| LAMPHOLDER                | G9  |
| MAX WATTAGE               | 6.5W  |
| VOLTAGE                   | 110/120v  |
| ENVIRONMENTAL RATING      | Dry Location (IP20)                                   |
| CLASS PROTECTION          | Class I   |
| SHADE                     | GL171   |
| FLEX   BAR   CHAIN LENGTH | 40"   |
| CABLE TYPE                | MLCA001   Black Fabric Braided Cable   2 Core Twisted |

### FIXING BRACKET: MLWB17 | Polished Brass

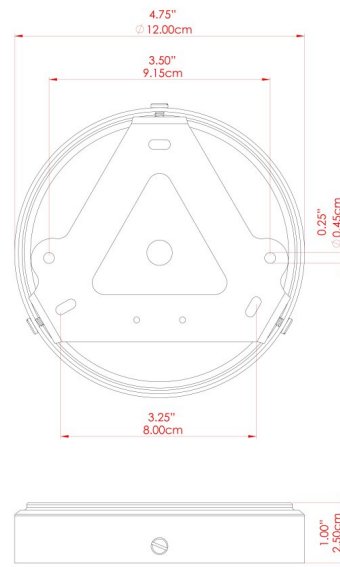

Product Notes:  
 1) Bulbs not included. 2) Dimensions do not include bulbs. 3) All products are individually made-to-order and therefore may differ slightly within manufacturing tolerances. 4) Cable / chain can be shortened during installation. Longer cable / chain lengths available on request. 5) Additional color finishes may be available on request. 6) Twisted cable is not available for UL wired products. Round cable in black or brown only is supplied instead. 7) Refer to our website for a full list of terms and conditions.





# HELENA Pendant

MLP460SATBRSL Satin Brass

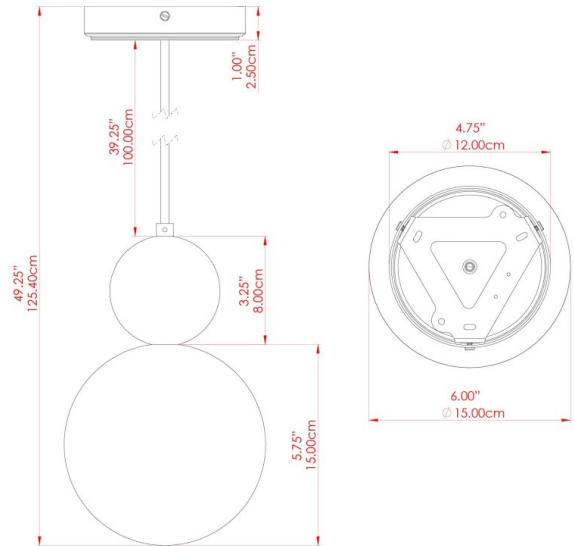

|                           |   |
|---------------------------|---|
| MATERIAL                  | Brass   Steel   Glass                                 |
| HEIGHT                    | 9.5"  |
| WIDTH   DIAMETER          | 6"  |
| LENGTH   PROJECTION       | n/a   |
| WEIGHT                    | 1 kg   2.3 lbs  |
| LAMPHOLDER                | G9  |
| MAX WATTAGE               | 6.5W  |
| VOLTAGE                   | 110/120v  |
| ENVIRONMENTAL RATING      | Dry Location (IP20)                                   |
| CLASS PROTECTION          | Class I   |
| SHADE                     | GL170   |
| FLEX   BAR   CHAIN LENGTH | 40"   |
| CABLE TYPE                | MLCA001   Black Fabric Braided Cable   2 Core Twisted |

### FIXING BRACKET: MLWB17 | Satin Brass

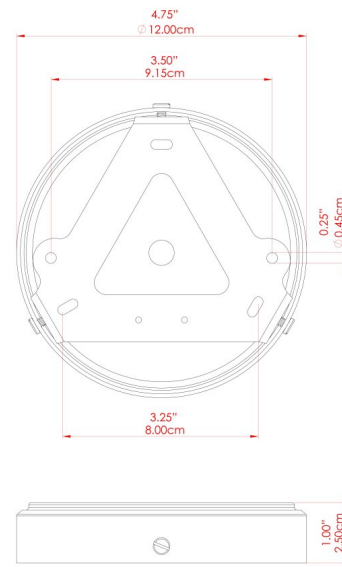

Product Notes:  
 1) Bulbs not included. 2) Dimensions do not include bulbs. 3) All products are individually made-to-order and therefore may differ slightly within manufacturing tolerances. 4) Cable / chain can be shortened during installation. Longer cable / chain lengths available on request. 5) Additional color finishes may be available on request. 6) Twisted cable is not available for UL wired products. Round cable in black or brown only is supplied instead. 7) Refer to our website for a full list of terms and conditions.



# HELENA Pendant

MLP460SATBRSFR Satin Brass

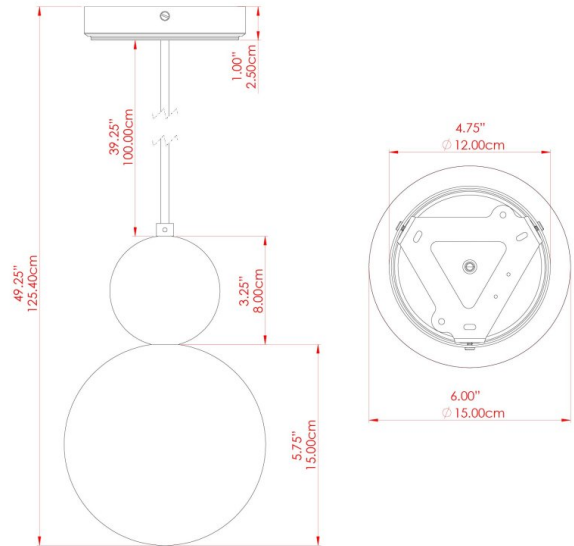

|                           |   |
|---------------------------|---|
| MATERIAL                  | Brass   Steel   Glass                                 |
| HEIGHT                    | 9.5"  |
| WIDTH   DIAMETER          | 6"  |
| LENGTH   PROJECTION       | n/a   |
| WEIGHT                    | 1 kg   2.3 lbs  |
| LAMPHOLDER                | G9  |
| MAX WATTAGE               | 6.5W  |
| VOLTAGE                   | 110/120v  |
| ENVIRONMENTAL RATING      | Dry Location (IP20)                                   |
| CLASS PROTECTION          | Class I   |
| SHADE                     | GL171   |
| FLEX   BAR   CHAIN LENGTH | 40"   |
| CABLE TYPE                | MLCA001   Black Fabric Braided Cable   2 Core Twisted |

### FIXING BRACKET: MLWB17 | Satin Brass

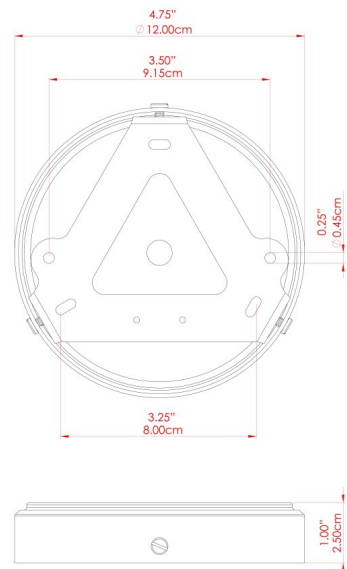

Product Notes:  
 1) Bulbs not included. 2) Dimensions do not include bulbs. 3) All products are individually made-to-order and therefore may differ slightly within manufacturing tolerances. 4) Cable / chain can be shortened during installation. Longer cable / chain lengths available on request. 5) Additional color finishes may be available on request. 6) Twisted cable is not available for UL wired products. Round cable in black or brown only is supplied instead. 7) Refer to our website for a full list of terms and conditions.

