

# GENEVA Pendant

# MLP371ANTBRS Antique Brass

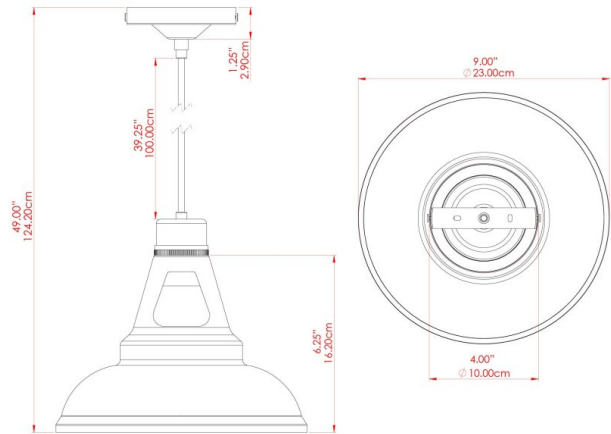

MATERIAL	Brass
HEIGHT	9"
WIDTH   DIAMETER	12"
LENGTH   PROJECTION	n/a
WEIGHT	0.8 kg   1.8 lbs
LAMPHOLDER	E26
MAX WATTAGE	60W
VOLTAGE	110/120v
ENVIRONMENTAL RATING	Dry Location (IP20)
CLASS PROTECTION	Class I
SHADE	-
FLEX   BAR   CHAIN LENGTH	40"
CABLE TYPE	MLCA072   Brown Fabric Braided Cable   2 Core Round   UL

### FIXING BRACKET: MLROSE39 | Antique Brass

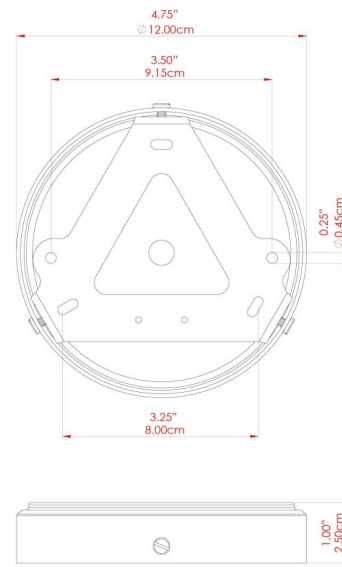

Product Notes:  
 1) Bulbs not included. 2) Dimensions do not include bulbs. 3) All products are individually made-to-order and therefore may differ slightly within manufacturing tolerances. 4) Cable / chain can be shortened during installation. Longer cable / chain lengths available on request. 5) Additional color finishes may be available on request. 6) Twisted cable is not available for UL wired products. Round cable in black or brown only is supplied instead. 7) Refer to our website for a full list of terms and conditions.





# GENEVA Pendant

MLP371ANTSLV Antique Silver

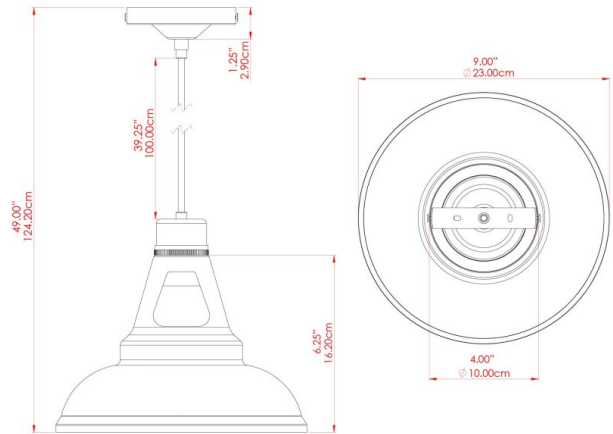

MATERIAL	Brass
HEIGHT	9"
WIDTH   DIAMETER	12"
LENGTH   PROJECTION	n/a
WEIGHT	0.8 kg   1.8 lbs
LAMPHOLDER	E26
MAX WATTAGE	60W
VOLTAGE	110/120v
ENVIRONMENTAL RATING	Dry Location (IP20)
CLASS PROTECTION	Class I
SHADE	-
FLEX   BAR   CHAIN LENGTH	40"
CABLE TYPE	MLCA020   Black Fabric Braided Cable   3 Core Twisted

## FIXING BRACKET: MLROSE39 | Antique Silver

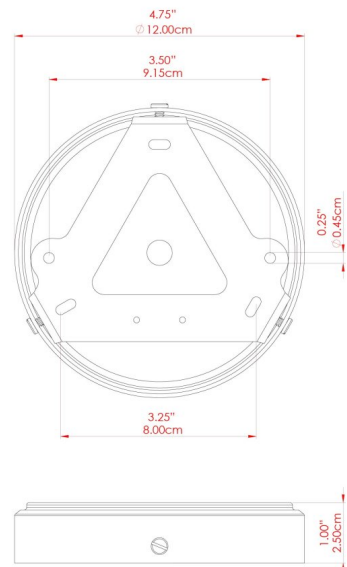

Product Notes:  
 1) Bulbs not included. 2) Dimensions do not include bulbs. 3) All products are individually made-to-order and therefore may differ slightly within manufacturing tolerances. 4) Cable / chain can be shortened during installation. Longer cable / chain lengths available on request. 5) Additional color finishes may be available on request. 6) Twisted cable is not available for UL wired products. Round cable in black or brown only is supplied instead. 7) Refer to our website for a full list of terms and conditions.





# GENEVA Pendant

MLP371POLBRS Polished Brass

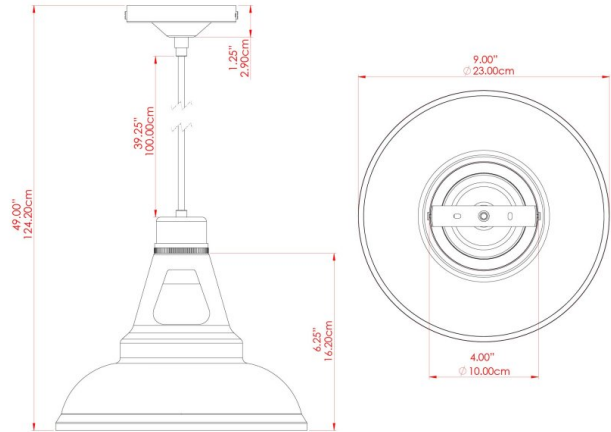

MATERIAL	Brass
HEIGHT	9"
WIDTH   DIAMETER	12"
LENGTH   PROJECTION	n/a
WEIGHT	0.8 kg   1.8 lbs
LAMPHOLDER	E26
MAX WATTAGE	60W
VOLTAGE	110/120v
ENVIRONMENTAL RATING	Dry Location (IP20)
CLASS PROTECTION	Class I
SHADE	-
FLEX   BAR   CHAIN LENGTH	40"
CABLE TYPE	MLCA020   Black Fabric Braided Cable   3 Core Twisted

## FIXING BRACKET: MLROSE39 | Polished Brass

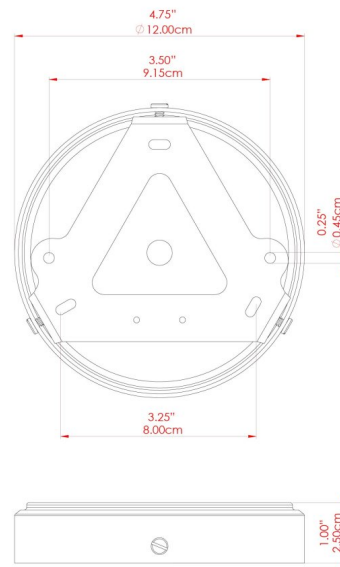

Product Notes:  
 1) Bulbs not included. 2) Dimensions do not include bulbs. 3) All products are individually made-to-order and therefore may differ slightly within manufacturing tolerances. 4) Cable / chain can be shortened during installation. Longer cable / chain lengths available on request. 5) Additional color finishes may be available on request. 6) Twisted cable is not available for UL wired products. Round cable in black or brown only is supplied instead. 7) Refer to our website for a full list of terms and conditions.





# GENEVA Pendant

MLP371SATBRS Satin Brass

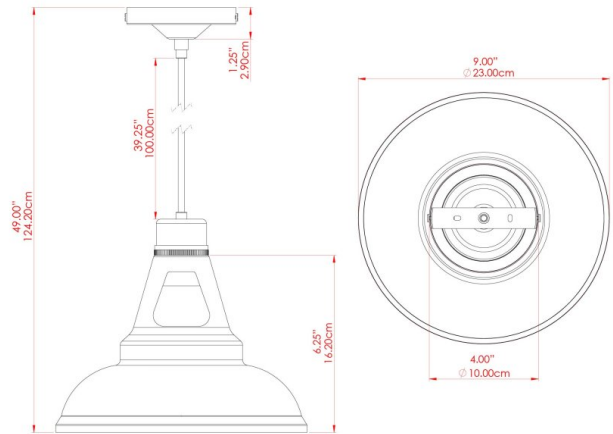

MATERIAL	Brass
HEIGHT	9"
WIDTH   DIAMETER	12"
LENGTH   PROJECTION	n/a
WEIGHT	0.8 kg   1.8 lbs
LAMPHOLDER	E26
MAX WATTAGE	60W
VOLTAGE	110/120v
ENVIRONMENTAL RATING	Dry Location (IP20)
CLASS PROTECTION	Class I
SHADE	-
FLEX   BAR   CHAIN LENGTH	40"
CABLE TYPE	MLCA072   Brown Fabric Braided Cable   2 Core Round   UL

## FIXING BRACKET: MLROSE39 | Satin Brass

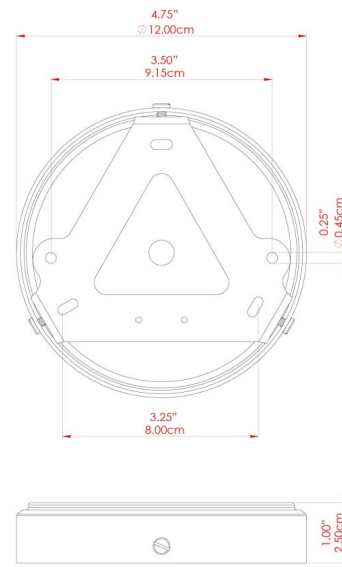

Product Notes:  
 1) Bulbs not included. 2) Dimensions do not include bulbs. 3) All products are individually made-to-order and therefore may differ slightly within manufacturing tolerances. 4) Cable / chain can be shortened during installation. Longer cable / chain lengths available on request. 5) Additional color finishes may be available on request. 6) Twisted cable is not available for UL wired products. Round cable in black or brown only is supplied instead. 7) Refer to our website for a full list of terms and conditions.

