

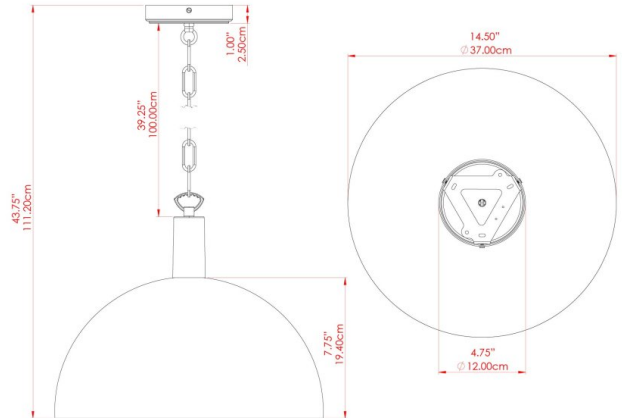

KAURI Ceramic Pendant

MLCMP063ANTBRS Antique Brass



MATERIAL	Brass Ceramic
HEIGHT	11"
WIDTH DIAMETER	14.5"
LENGTH PROJECTION	n/a
WEIGHT	8.5 kg 18.8 lbs
LAMPHOLDER	E26
MAX WATTAGE	40W
VOLTAGE	110/120v
ENVIRONMENTAL RATING	Dry Location (IP20)
CLASS PROTECTION	Class I
SHADE	MLCS050
FLEX BAR CHAIN LENGTH	40"
CABLE TYPE	MLCA010 Brown PVC Flexible Cable 2 Core

FIXING BRACKET: MLWB17

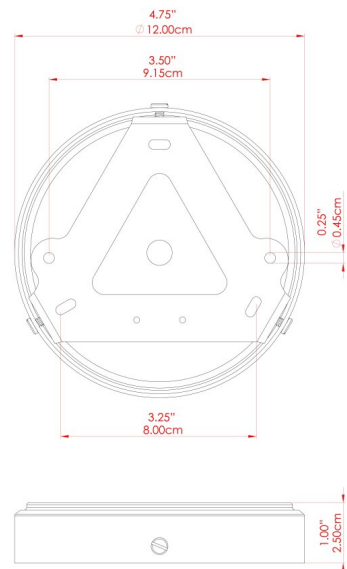

Product Notes:
 1) Bulbs not included. 2) Dimensions do not include bulbs. 3) All products are individually made-to-order and therefore may differ slightly within manufacturing tolerances. 4) Cable / chain can be shortened during installation. Longer cable / chain lengths available on request. 5) Additional color finishes may be available on request. 6) Twisted cable is not available for UL wired products. Round cable in black or brown only is supplied instead. 7) Refer to our website for a full list of terms and conditions.





KAURI Ceramic Pendant

MLCMP063ANTSLV Antique Silver

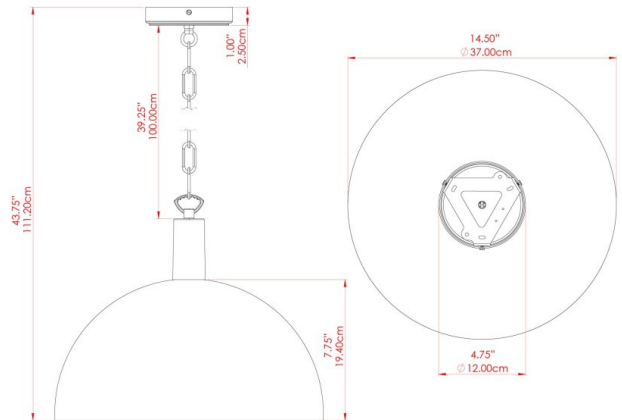

MATERIAL	Brass Ceramic
HEIGHT	11"
WIDTH DIAMETER	14.5"
LENGTH PROJECTION	n/a
WEIGHT	8.5 kg 18.8 lbs
LAMPHOLDER	E26
MAX WATTAGE	40W
VOLTAGE	110/120v
ENVIRONMENTAL RATING	Dry Location (IP20)
CLASS PROTECTION	Class I
SHADE	MLCS050
FLEX BAR CHAIN LENGTH	40"
CABLE TYPE	MLCA014 Clear PVC Flexible Cable 2 Core

FIXING BRACKET: MLWB17

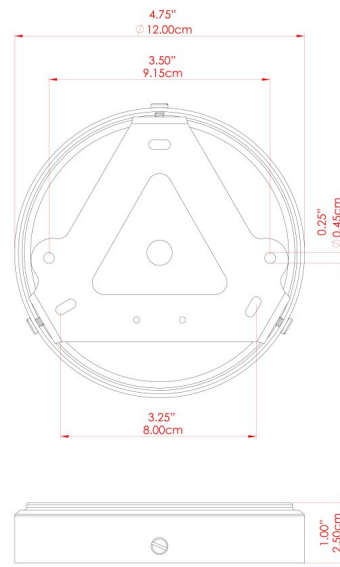

Product Notes:
 1) Bulbs not included. 2) Dimensions do not include bulbs. 3) All products are individually made-to-order and therefore may differ slightly within manufacturing tolerances. 4) Cable / chain can be shortened during installation. Longer cable / chain lengths available on request. 5) Additional color finishes may be available on request. 6) Twisted cable is not available for UL wired products. Round cable in black or brown only is supplied instead. 7) Refer to our website for a full list of terms and conditions.





KAURI Ceramic Pendant

MLCMP063PCMBK Matt Black

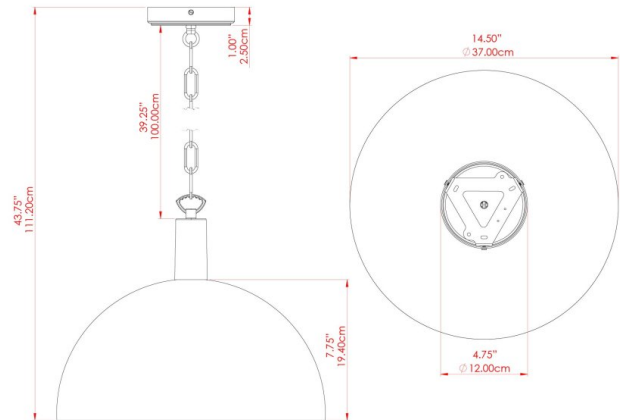

MATERIAL	Brass Ceramic
HEIGHT	11"
WIDTH DIAMETER	14.5"
LENGTH PROJECTION	n/a
WEIGHT	8.5 kg 18.8 lbs
LAMPHOLDER	E26
MAX WATTAGE	40W
VOLTAGE	110/120v
ENVIRONMENTAL RATING	Dry Location (IP20)
CLASS PROTECTION	Class I
SHADE	MLCS050
FLEX BAR CHAIN LENGTH	40"
CABLE TYPE	MLCA009 Black PVC Flexible Cable 2 Core

FIXING BRACKET: MLWB17

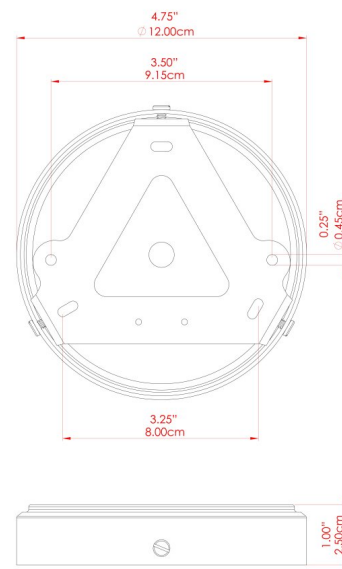

WWW.MULLANLIGHTING.COM

Product Notes:

1) Bulbs not included. 2) Dimensions do not include bulbs. 3) All products are individually made-to-order and therefore may differ slightly within manufacturing tolerances. 4) Cable / chain can be shortened during installation. Longer cable / chain lengths available on request. 5) Additional color finishes may be available on request. 6) Twisted cable is not available for UL wired products. Round cable in black or brown only is supplied instead. 7) Refer to our website for a full list of terms and conditions.





KAURI Ceramic Pendant

MLCMP063POLBRS Polished Brass

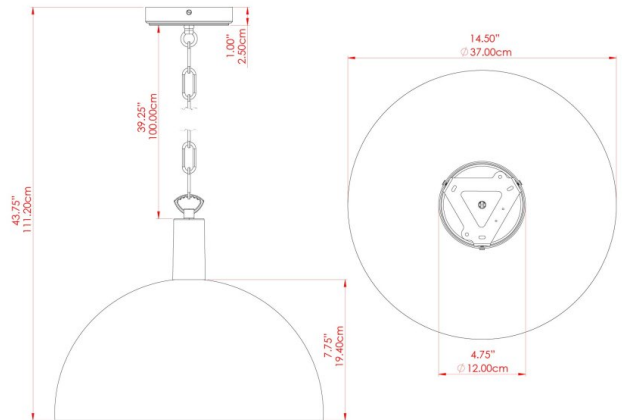

MATERIAL	Brass Ceramic
HEIGHT	11"
WIDTH DIAMETER	14.5"
LENGTH PROJECTION	n/a
WEIGHT	8.5 kg 18.8 lbs
LAMPHOLDER	E26
MAX WATTAGE	40W
VOLTAGE	110/120v
ENVIRONMENTAL RATING	Dry Location (IP20)
CLASS PROTECTION	Class I
SHADE	MLCS050
FLEX BAR CHAIN LENGTH	40"
CABLE TYPE	MLCA038 Gold PVC Flexible Cable 2 Core

FIXING BRACKET: MLWB17

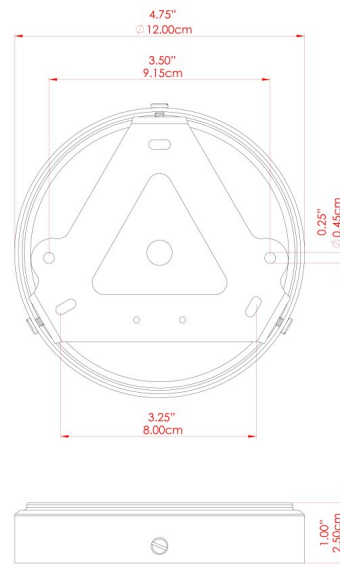

Product Notes:
 1) Bulbs not included. 2) Dimensions do not include bulbs. 3) All products are individually made-to-order and therefore may differ slightly within manufacturing tolerances. 4) Cable / chain can be shortened during installation. Longer cable / chain lengths available on request. 5) Additional color finishes may be available on request. 6) Twisted cable is not available for UL wired products. Round cable in black or brown only is supplied instead. 7) Refer to our website for a full list of terms and conditions.





KAURI Ceramic Pendant

MLCMP063SATBRS Satin Brass

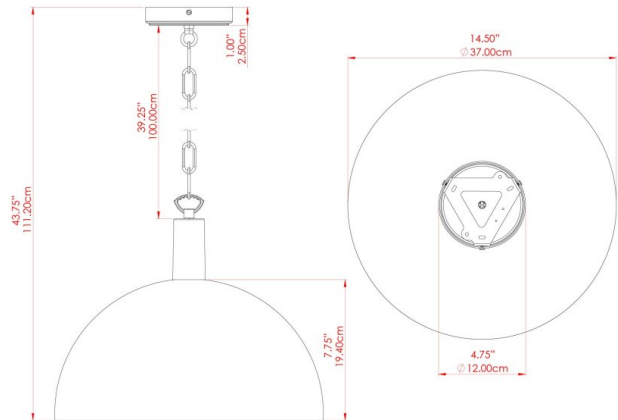

MATERIAL	Brass Ceramic
HEIGHT	11"
WIDTH DIAMETER	14.5"
LENGTH PROJECTION	n/a
WEIGHT	8.5 kg 18.8 lbs
LAMPHOLDER	E26
MAX WATTAGE	40W
VOLTAGE	110/120v
ENVIRONMENTAL RATING	Dry Location (IP20)
CLASS PROTECTION	Class I
SHADE	MLCS050
FLEX BAR CHAIN LENGTH	40"
CABLE TYPE	MLCA038 Gold PVC Flexible Cable 2 Core

FIXING BRACKET: MLWB17

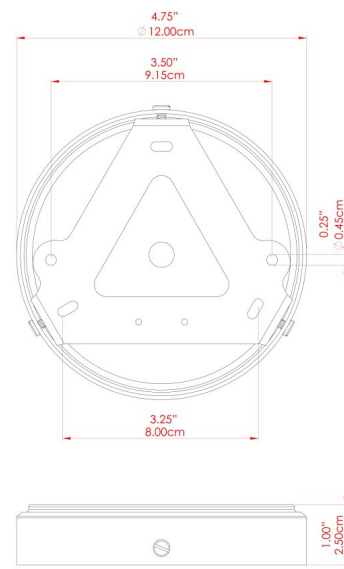

Product Notes:
 1) Bulbs not included. 2) Dimensions do not include bulbs. 3) All products are individually made-to-order and therefore may differ slightly within manufacturing tolerances. 4) Cable / chain can be shortened during installation. Longer cable / chain lengths available on request. 5) Additional color finishes may be available on request. 6) Twisted cable is not available for UL wired products. Round cable in black or brown only is supplied instead. 7) Refer to our website for a full list of terms and conditions.

