

BELFAST Picture Light

MPL037ANTBRS Antique Brass

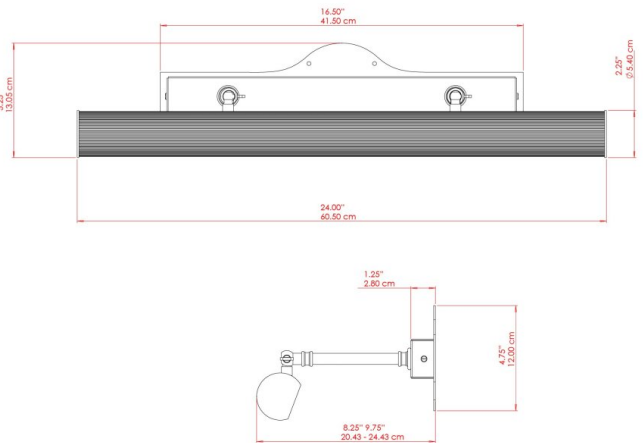

MATERIAL	Brass
HEIGHT	5"
WIDTH DIAMETER	23.75"
LENGTH PROJECTION	7.75"
WEIGHT	0.8 kg 1.8 lbs
LAMPHOLDER	G9
MAX WATTAGE	6.5W
VOLTAGE	110/120v
ENVIRONMENTAL RATING	Dry Location (IP20)
CLASS PROTECTION	Class I
SHADE	-
FLEX BAR CHAIN LENGTH	n/a
CABLE TYPE	

FIXING BRACKET: MLWB32

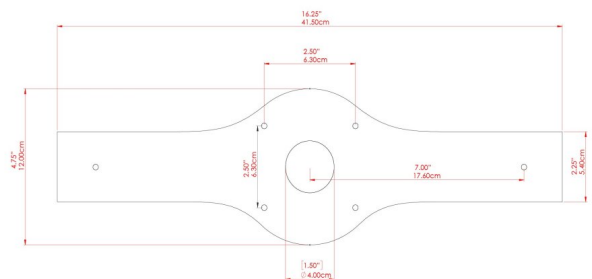

Product Notes:
 1) Bulbs not included. 2) Dimensions do not include bulbs. 3) All products are individually made-to-order and therefore may differ slightly within manufacturing tolerances. 4) Cable / chain can be shortened during installation. Longer cable / chain lengths available on request. 5) Additional color finishes may be available on request. 6) Twisted cable is not available for UL wired products. Round cable in black or brown only is supplied instead. 7) Refer to our website for a full list of terms and conditions.



BELFAST Picture Light

MPL037ANTSLV Antique Silver

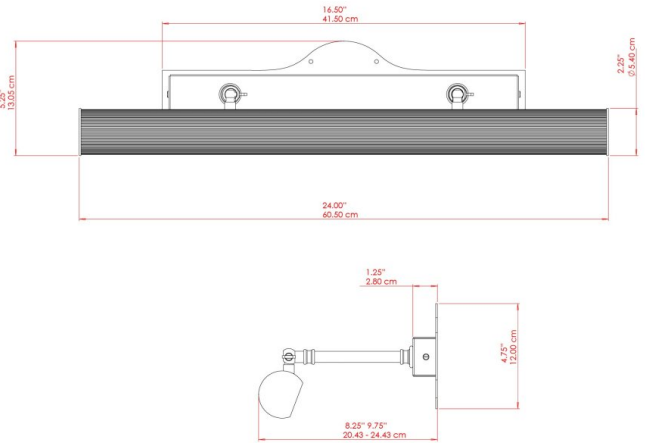

MATERIAL	Brass
HEIGHT	5"
WIDTH DIAMETER	23.75"
LENGTH PROJECTION	7.75"
WEIGHT	0.8 kg 1.8 lbs
LAMPHOLDER	G9
MAX WATTAGE	6.5W
VOLTAGE	110/120v
ENVIRONMENTAL RATING	Dry Location (IP20)
CLASS PROTECTION	Class I
SHADE	-
FLEX BAR CHAIN LENGTH	n/a
CABLE TYPE	

FIXING BRACKET: MLWB32

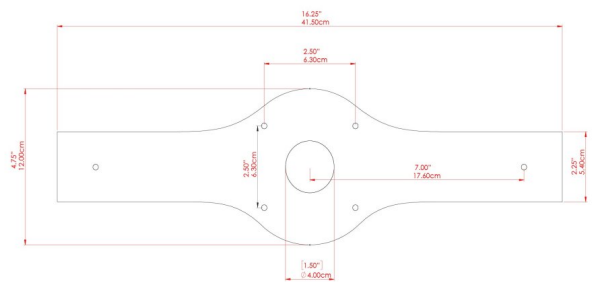

Product Notes:
 1) Bulbs not included. 2) Dimensions do not include bulbs. 3) All products are individually made-to-order and therefore may differ slightly within manufacturing tolerances. 4) Cable / chain can be shortened during installation. Longer cable / chain lengths available on request. 5) Additional color finishes may be available on request. 6) Twisted cable is not available for UL wired products. Round cable in black or brown only is supplied instead. 7) Refer to our website for a full list of terms and conditions.





BELFAST Picture Light

MPL037PCBLK Black

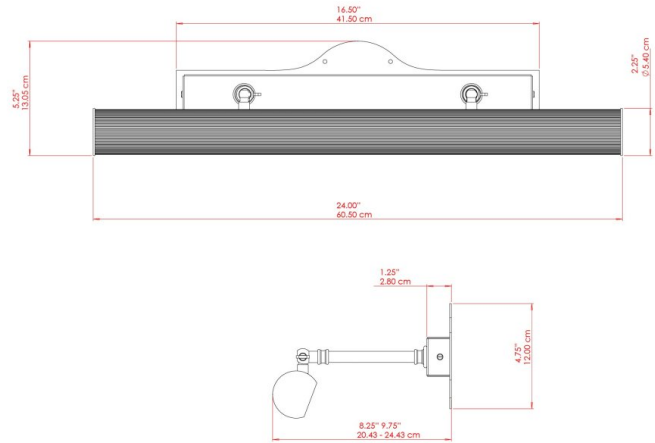

MATERIAL	Brass
HEIGHT	5"
WIDTH DIAMETER	23.75"
LENGTH PROJECTION	7.75"
WEIGHT	0.8 kg 1.8 lbs
LAMPHOLDER	G9
MAX WATTAGE	6.5W
VOLTAGE	110/120v
ENVIRONMENTAL RATING	Dry Location (IP20)
CLASS PROTECTION	Class I
SHADE	-
FLEX BAR CHAIN LENGTH	n/a
CABLE TYPE	

FIXING BRACKET: MLWB32

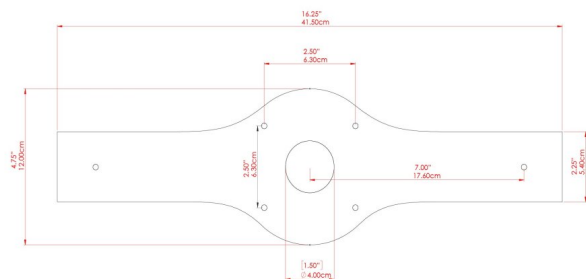

Product Notes:
 1) Bulbs not included. 2) Dimensions do not include bulbs. 3) All products are individually made-to-order and therefore may differ slightly within manufacturing tolerances. 4) Cable / chain can be shortened during installation. Longer cable / chain lengths available on request. 5) Additional color finishes may be available on request. 6) Twisted cable is not available for UL wired products. Round cable in black or brown only is supplied instead. 7) Refer to our website for a full list of terms and conditions.





BELFAST Picture Light

MPL037PCMBK Matt Black

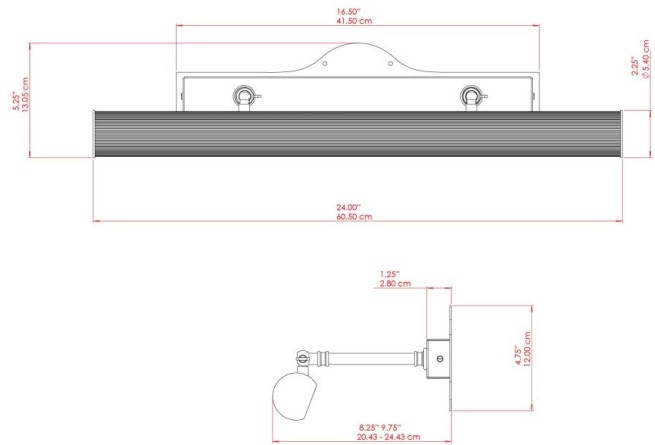

MATERIAL	Brass
HEIGHT	5"
WIDTH DIAMETER	23.75"
LENGTH PROJECTION	7.75"
WEIGHT	0.8 kg 1.8 lbs
LAMPHOLDER	G9
MAX WATTAGE	6.5W
VOLTAGE	110/120v
ENVIRONMENTAL RATING	Dry Location (IP20)
CLASS PROTECTION	Class I
SHADE	-
FLEX BAR CHAIN LENGTH	n/a
CABLE TYPE	

FIXING BRACKET: MLWB32

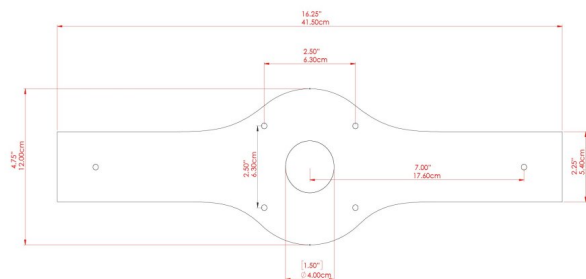

Product Notes:
 1) Bulbs not included. 2) Dimensions do not include bulbs. 3) All products are individually made-to-order and therefore may differ slightly within manufacturing tolerances. 4) Cable / chain can be shortened during installation. Longer cable / chain lengths available on request. 5) Additional color finishes may be available on request. 6) Twisted cable is not available for UL wired products. Round cable in black or brown only is supplied instead. 7) Refer to our website for a full list of terms and conditions.





BELFAST Picture Light

MPL037POLBRS Polished Brass

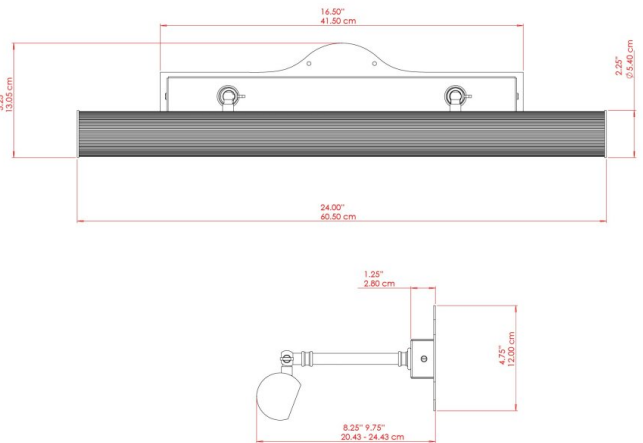

MATERIAL	Brass
HEIGHT	5"
WIDTH DIAMETER	23.75"
LENGTH PROJECTION	7.75"
WEIGHT	0.8 kg 1.8 lbs
LAMPHOLDER	G9
MAX WATTAGE	6.5W
VOLTAGE	110/120v
ENVIRONMENTAL RATING	Dry Location (IP20)
CLASS PROTECTION	Class I
SHADE	-
FLEX BAR CHAIN LENGTH	n/a
CABLE TYPE	

FIXING BRACKET: MLWB32

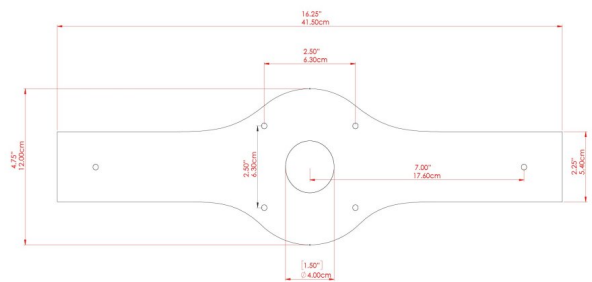

Product Notes:
 1) Bulbs not included. 2) Dimensions do not include bulbs. 3) All products are individually made-to-order and therefore may differ slightly within manufacturing tolerances. 4) Cable / chain can be shortened during installation. Longer cable / chain lengths available on request. 5) Additional color finishes may be available on request. 6) Twisted cable is not available for UL wired products. Round cable in black or brown only is supplied instead. 7) Refer to our website for a full list of terms and conditions.



BELFAST Picture Light

MPL037SATBRS Satin Brass

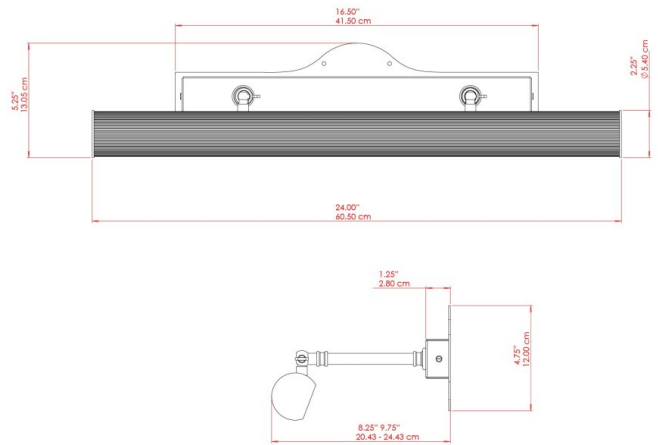

MATERIAL	Brass
HEIGHT	5"
WIDTH DIAMETER	23.75"
LENGTH PROJECTION	7.75"
WEIGHT	0.8 kg 1.8 lbs
LAMPHOLDER	G9
MAX WATTAGE	6.5W
VOLTAGE	110/120v
ENVIRONMENTAL RATING	Dry Location (IP20)
CLASS PROTECTION	Class I
SHADE	-
FLEX BAR CHAIN LENGTH	n/a
CABLE TYPE	

FIXING BRACKET: MLWB32

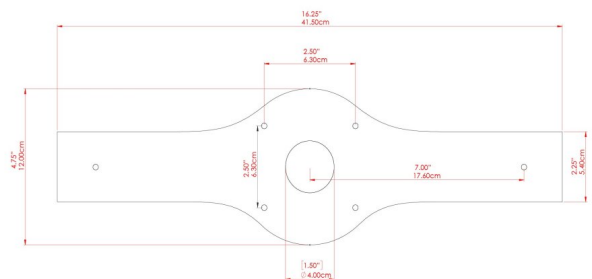

Product Notes:
 1) Bulbs not included. 2) Dimensions do not include bulbs. 3) All products are individually made-to-order and therefore may differ slightly within manufacturing tolerances. 4) Cable / chain can be shortened during installation. Longer cable / chain lengths available on request. 5) Additional color finishes may be available on request. 6) Twisted cable is not available for UL wired products. Round cable in black or brown only is supplied instead. 7) Refer to our website for a full list of terms and conditions.

