

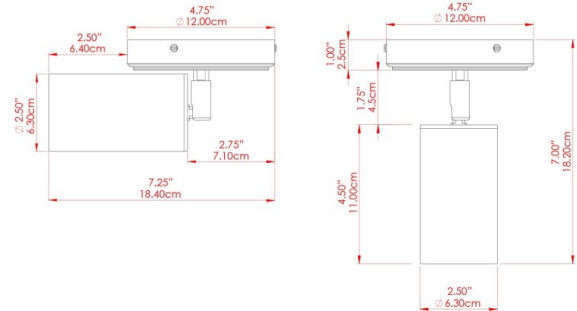

EVANSTON Ceiling Light

MLCF121ANTBRS Antique Brass



MATERIAL	Brass
HEIGHT	7.75"
WIDTH DIAMETER	3.25"
LENGTH PROJECTION	n/a
WEIGHT	0.8 kg 1.8 lbs
LAMPHOLDER	GU10
MAX WATTAGE	5W
VOLTAGE	110/120v
ENVIRONMENTAL RATING	Dry Location (IP20)
CLASS PROTECTION	Class I
SHADE	-
FLEX BAR CHAIN LENGTH	n/a
CABLE TYPE	MLCA009 Black PVC Flexible Cable 2 Core

FIXING BRACKET: MLWB17 | Antique Brass

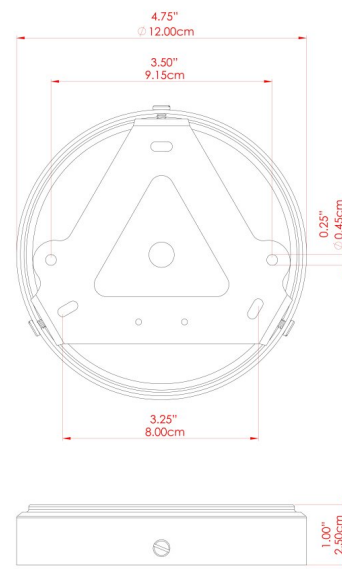

Product Notes:
 1) Bulbs not included. 2) Dimensions do not include bulbs. 3) All products are individually made-to-order and therefore may differ slightly within manufacturing tolerances. 4) Cable / chain can be shortened during installation. Longer cable / chain lengths available on request. 5) Additional color finishes may be available on request. 6) Twisted cable is not available for UL wired products. Round cable in black or brown only is supplied instead. 7) Refer to our website for a full list of terms and conditions.





EVANSTON Ceiling Light

MLCF121ANTSLV Antique Silver

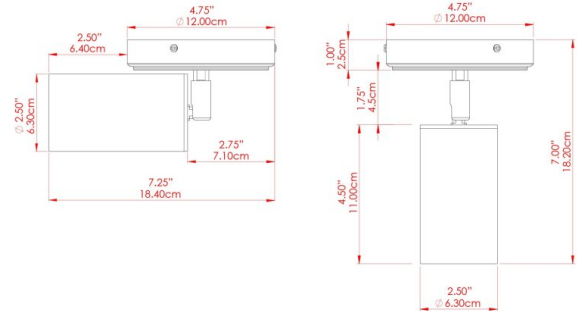

MATERIAL	Brass
HEIGHT	7.75"
WIDTH DIAMETER	3.25"
LENGTH PROJECTION	n/a
WEIGHT	0.8 kg 1.8 lbs
LAMPHOLDER	GU10
MAX WATTAGE	5W
VOLTAGE	110/120v
ENVIRONMENTAL RATING	Dry Location (IP20)
CLASS PROTECTION	Class I
SHADE	-
FLEX BAR CHAIN LENGTH	n/a
CABLE TYPE	MLCA009 Black PVC Flexible Cable 2 Core

FIXING BRACKET: MLWB17 | Antique Silver

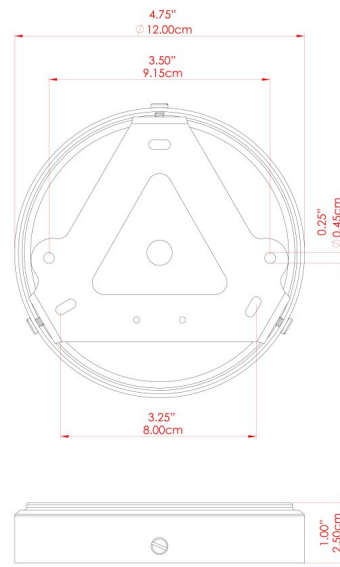

Product Notes:
 1) Bulbs not included. 2) Dimensions do not include bulbs. 3) All products are individually made-to-order and therefore may differ slightly within manufacturing tolerances. 4) Cable / chain can be shortened during installation. Longer cable / chain lengths available on request. 5) Additional color finishes may be available on request. 6) Twisted cable is not available for UL wired products. Round cable in black or brown only is supplied instead. 7) Refer to our website for a full list of terms and conditions.





EVANSTON Ceiling Light

MLCF121POLBRS Polished Brass

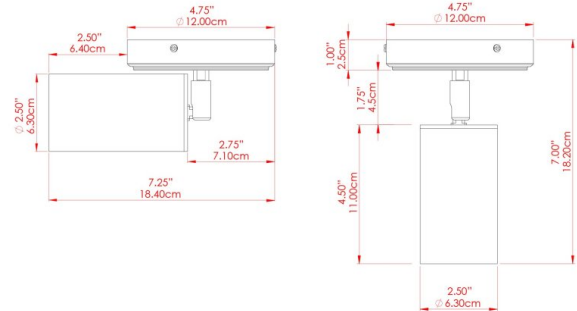

MATERIAL	Brass
HEIGHT	7.75"
WIDTH DIAMETER	3.25"
LENGTH PROJECTION	n/a
WEIGHT	0.8 kg 1.8 lbs
LAMPHOLDER	GU10
MAX WATTAGE	5W
VOLTAGE	110/120v
ENVIRONMENTAL RATING	Dry Location (IP20)
CLASS PROTECTION	Class I
SHADE	-
FLEX BAR CHAIN LENGTH	n/a
CABLE TYPE	MLCA009 Black PVC Flexible Cable 2 Core

FIXING BRACKET: MLWB17 | Polished Brass

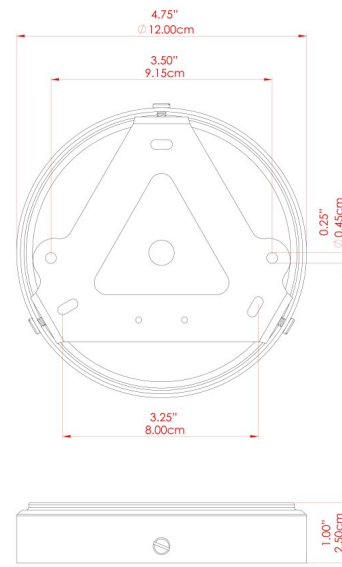

Product Notes:
 1) Bulbs not included. 2) Dimensions do not include bulbs. 3) All products are individually made-to-order and therefore may differ slightly within manufacturing tolerances. 4) Cable / chain can be shortened during installation. Longer cable / chain lengths available on request. 5) Additional color finishes may be available on request. 6) Twisted cable is not available for UL wired products. Round cable in black or brown only is supplied instead. 7) Refer to our website for a full list of terms and conditions.





EVANSTON Ceiling Light

MLCF121SATBRS Satin Brass

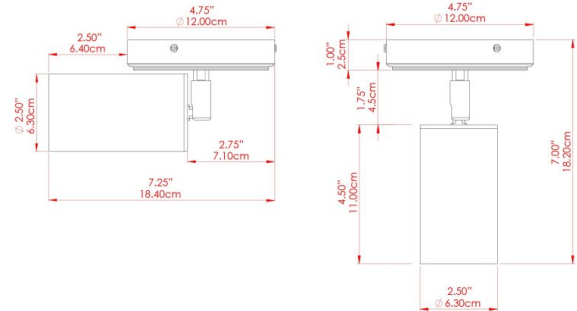

MATERIAL	Brass
HEIGHT	7.75"
WIDTH DIAMETER	3.25"
LENGTH PROJECTION	n/a
WEIGHT	0.8 kg 1.8 lbs
LAMPHOLDER	GU10
MAX WATTAGE	5W
VOLTAGE	110/120v
ENVIRONMENTAL RATING	Dry Location (IP20)
CLASS PROTECTION	Class I
SHADE	-
FLEX BAR CHAIN LENGTH	n/a
CABLE TYPE	MLCA009 Black PVC Flexible Cable 2 Core

FIXING BRACKET: MLWB17 | Satin Brass

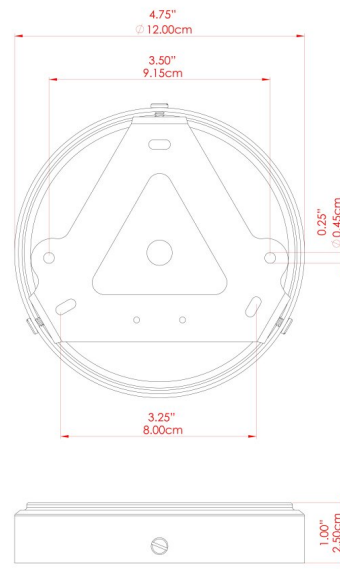

Product Notes:
 1) Bulbs not included. 2) Dimensions do not include bulbs. 3) All products are individually made-to-order and therefore may differ slightly within manufacturing tolerances. 4) Cable / chain can be shortened during installation. Longer cable / chain lengths available on request. 5) Additional color finishes may be available on request. 6) Twisted cable is not available for UL wired products. Round cable in black or brown only is supplied instead. 7) Refer to our website for a full list of terms and conditions.





EVANSTON Ceiling Light

MLCF121PCMBK Matt Black

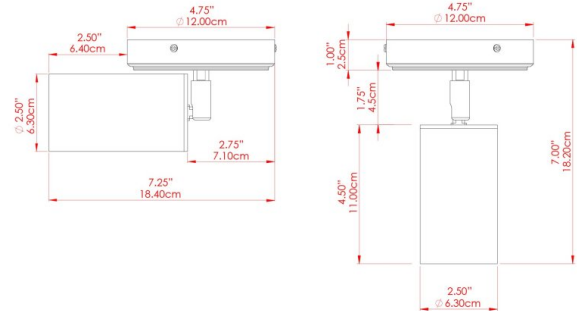

MATERIAL	Brass
HEIGHT	7.75"
WIDTH DIAMETER	3.25"
LENGTH PROJECTION	n/a
WEIGHT	0.8 kg 1.8 lbs
LAMPHOLDER	GU10
MAX WATTAGE	5W
VOLTAGE	110/120v
ENVIRONMENTAL RATING	Dry Location (IP20)
CLASS PROTECTION	Class I
SHADE	-
FLEX BAR CHAIN LENGTH	n/a
CABLE TYPE	MLCA009 Black PVC Flexible Cable 2 Core

FIXING BRACKET: MLWB17 | Matte Black

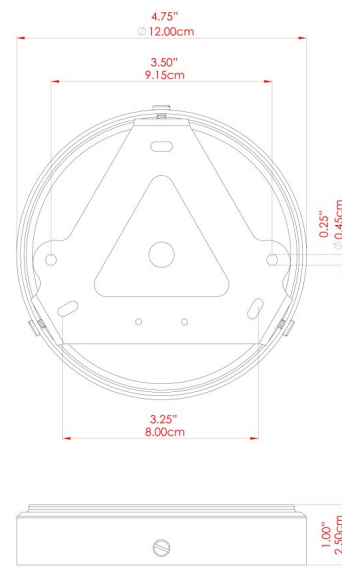

Product Notes:
 1) Bulbs not included. 2) Dimensions do not include bulbs. 3) All products are individually made-to-order and therefore may differ slightly within manufacturing tolerances. 4) Cable / chain can be shortened during installation. Longer cable / chain lengths available on request. 5) Additional color finishes may be available on request. 6) Twisted cable is not available for UL wired products. Round cable in black or brown only is supplied instead. 7) Refer to our website for a full list of terms and conditions.





EVANSTON Ceiling Light

MLCF121PCMMT

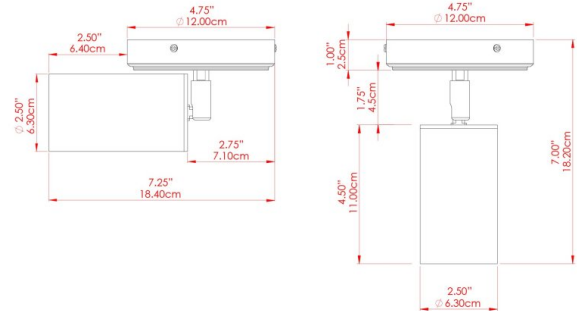

MATERIAL	Brass
HEIGHT	7.75"
WIDTH DIAMETER	3.25"
LENGTH PROJECTION	n/a
WEIGHT	0.8 kg 1.8 lbs
LAMPHOLDER	GU10
MAX WATTAGE	5W
VOLTAGE	110/120v
ENVIRONMENTAL RATING	Dry Location (IP20)
CLASS PROTECTION	Class I
SHADE	
FLEX BAR CHAIN LENGTH	n/a
CABLE TYPE	MLCA009 Black PVC Flexible Cable 2 Core

FIXING BRACKET: MLWB17 | PC Mint Turquoise

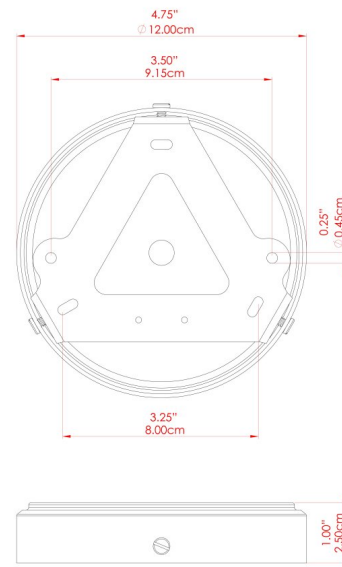

Product Notes:
 1) Bulbs not included. 2) Dimensions do not include bulbs. 3) All products are individually made-to-order and therefore may differ slightly within manufacturing tolerances. 4) Cable / chain can be shortened during installation. Longer cable / chain lengths available on request. 5) Additional color finishes may be available on request. 6) Twisted cable is not available for UL wired products. Round cable in black or brown only is supplied instead. 7) Refer to our website for a full list of terms and conditions.





EVANSTON Ceiling Light

MLCF121PCMSB

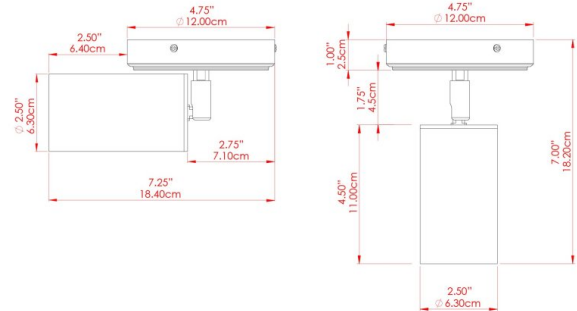

MATERIAL	Brass
HEIGHT	7.75"
WIDTH DIAMETER	3.25"
LENGTH PROJECTION	n/a
WEIGHT	0.8 kg 1.8 lbs
LAMPHOLDER	GU10
MAX WATTAGE	5W
VOLTAGE	110/120v
ENVIRONMENTAL RATING	Dry Location (IP20)
CLASS PROTECTION	Class I
SHADE	
FLEX BAR CHAIN LENGTH	n/a
CABLE TYPE	MLCA009 Black PVC Flexible Cable 2 Core

FIXING BRACKET: MLWB17 | PC Sapphire Blue

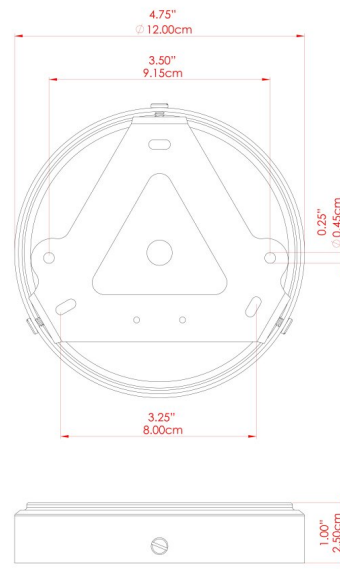

Product Notes:
 1) Bulbs not included. 2) Dimensions do not include bulbs. 3) All products are individually made-to-order and therefore may differ slightly within manufacturing tolerances. 4) Cable / chain can be shortened during installation. Longer cable / chain lengths available on request. 5) Additional color finishes may be available on request. 6) Twisted cable is not available for UL wired products. Round cable in black or brown only is supplied instead. 7) Refer to our website for a full list of terms and conditions.



EVANSTON Ceiling Light

MLCF121PCMAP

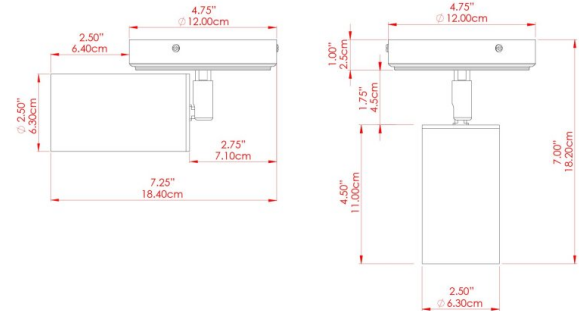

MATERIAL	Brass
HEIGHT	7.75"
WIDTH DIAMETER	3.25"
LENGTH PROJECTION	n/a
WEIGHT	0.8 kg 1.8 lbs
LAMPHOLDER	GU10
MAX WATTAGE	5W
VOLTAGE	110/120v
ENVIRONMENTAL RATING	Dry Location (IP20)
CLASS PROTECTION	Class I
SHADE	
FLEX BAR CHAIN LENGTH	n/a
CABLE TYPE	MLCA009 Black PVC Flexible Cable 2 Core

FIXING BRACKET: MLWB17 | PC Antique Pink

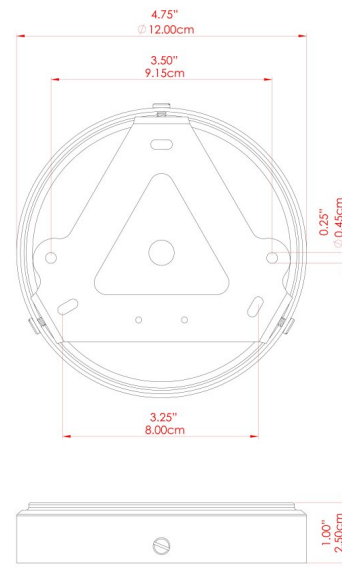

Product Notes:
 1) Bulbs not included. 2) Dimensions do not include bulbs. 3) All products are individually made-to-order and therefore may differ slightly within manufacturing tolerances. 4) Cable / chain can be shortened during installation. Longer cable / chain lengths available on request. 5) Additional color finishes may be available on request. 6) Twisted cable is not available for UL wired products. Round cable in black or brown only is supplied instead. 7) Refer to our website for a full list of terms and conditions.





EVANSTON Ceiling Light

MLCF121PCMHY

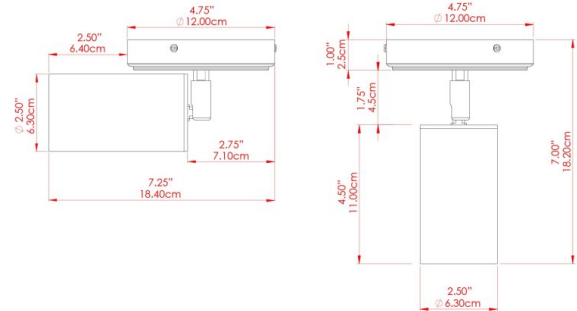

MATERIAL	Brass
HEIGHT	7.75"
WIDTH DIAMETER	3.25"
LENGTH PROJECTION	n/a
WEIGHT	0.8 kg 1.8 lbs
LAMPHOLDER	GU10
MAX WATTAGE	5W
VOLTAGE	110/120v
ENVIRONMENTAL RATING	Dry Location (IP20)
CLASS PROTECTION	Class I
SHADE	
FLEX BAR CHAIN LENGTH	n/a
CABLE TYPE	MLCA009 Black PVC Flexible Cable 2 Core

FIXING BRACKET: MLWB17 | PC Mustard Honey Yellow

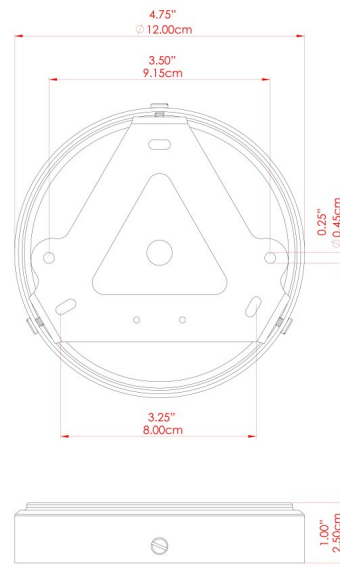

Product Notes:
 1) Bulbs not included. 2) Dimensions do not include bulbs. 3) All products are individually made-to-order and therefore may differ slightly within manufacturing tolerances. 4) Cable / chain can be shortened during installation. Longer cable / chain lengths available on request. 5) Additional color finishes may be available on request. 6) Twisted cable is not available for UL wired products. Round cable in black or brown only is supplied instead. 7) Refer to our website for a full list of terms and conditions.

