

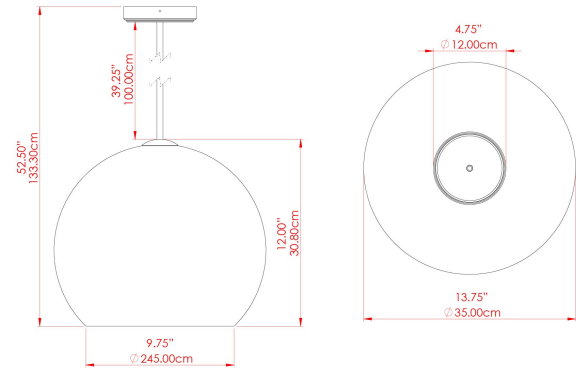

CLERMONT Chandelier

MLF354ANTBRS Antique Brass



MATERIAL	Brass Steel
HEIGHT	37.5"
WIDTH DIAMETER	13.75"
LENGTH PROJECTION	n/a
WEIGHT	2.8 kg 6.3 lbs
LAMPHOLDER	E12
MAX WATTAGE	40W
VOLTAGE	110/120v
ENVIRONMENTAL RATING	Dry Location (IP20)
CLASS PROTECTION	Class I
SHADE	GL134
FLEX BAR CHAIN LENGTH	40"
CABLE TYPE	

FIXING BRACKET: MLWB17

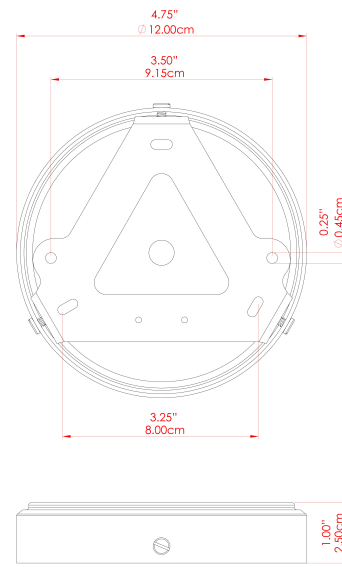

Product Notes:
 1) Bulbs not included. 2) Dimensions do not include bulbs. 3) All products are individually made-to-order and therefore may differ slightly within manufacturing tolerances. 4) Cable / chain can be shortened during installation. Longer cable / chain lengths available on request. 5) Additional color finishes may be available on request. 6) Twisted cable is not available for UL wired products. Round cable in black or brown only is supplied instead. 7) Refer to our website for a full list of terms and conditions.



CLERMONT Chandelier

MLF354ANTSLV Antique Silver

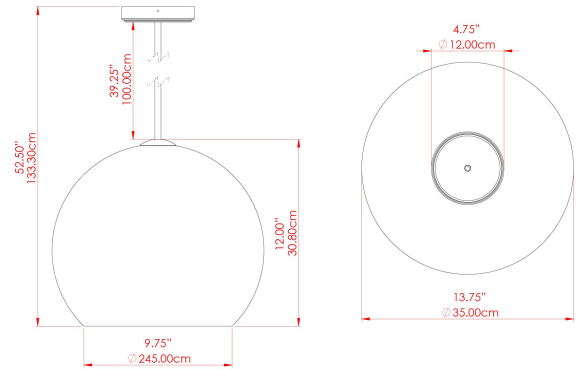

MATERIAL	Brass Steel
HEIGHT	37.5"
WIDTH DIAMETER	13.75"
LENGTH PROJECTION	n/a
WEIGHT	2.8 kg 6.3 lbs
LAMPHOLDER	E12
MAX WATTAGE	40W
VOLTAGE	110/120v
ENVIRONMENTAL RATING	Dry Location (IP20)
CLASS PROTECTION	Class I
SHADE	GL134
FLEX BAR CHAIN LENGTH	40"
CABLE TYPE	

FIXING BRACKET: MLWB17

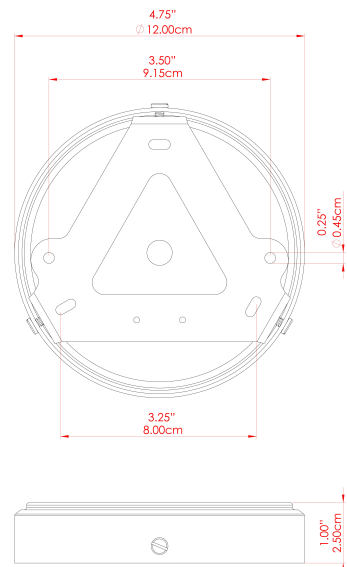

Product Notes:
 1) Bulbs not included. 2) Dimensions do not include bulbs. 3) All products are individually made-to-order and therefore may differ slightly within manufacturing tolerances. 4) Cable / chain can be shortened during installation. Longer cable / chain lengths available on request. 5) Additional color finishes may be available on request. 6) Twisted cable is not available for UL wired products. Round cable in black or brown only is supplied instead. 7) Refer to our website for a full list of terms and conditions.





CLERMONT Chandelier

MLF354PCMBK Matt Black

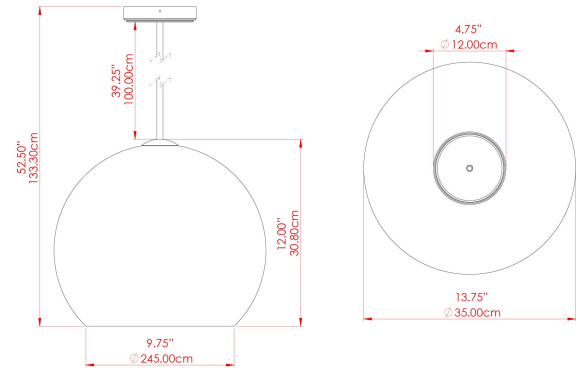

MATERIAL	Brass Steel
HEIGHT	37.5"
WIDTH DIAMETER	13.75"
LENGTH PROJECTION	n/a
WEIGHT	2.8 kg 6.3 lbs
LAMPHOLDER	E12
MAX WATTAGE	40W
VOLTAGE	110/120v
ENVIRONMENTAL RATING	Dry Location (IP20)
CLASS PROTECTION	Class I
SHADE	GL134
FLEX BAR CHAIN LENGTH	40"
CABLE TYPE	

FIXING BRACKET: MLWB17

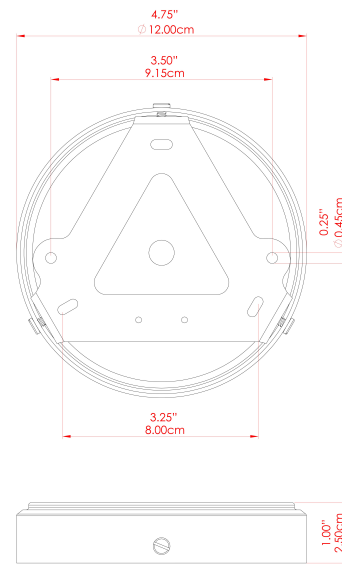

WWW.MULLANLIGHTING.COM

Product Notes:

1) Bulbs not included. 2) Dimensions do not include bulbs. 3) All products are individually made-to-order and therefore may differ slightly within manufacturing tolerances. 4) Cable / chain can be shortened during installation. Longer cable / chain lengths available on request. 5) Additional color finishes may be available on request. 6) Twisted cable is not available for UL wired products. Round cable in black or brown only is supplied instead. 7) Refer to our website for a full list of terms and conditions.





CLERMONT Chandelier

MLF354POLBRS Polished Brass

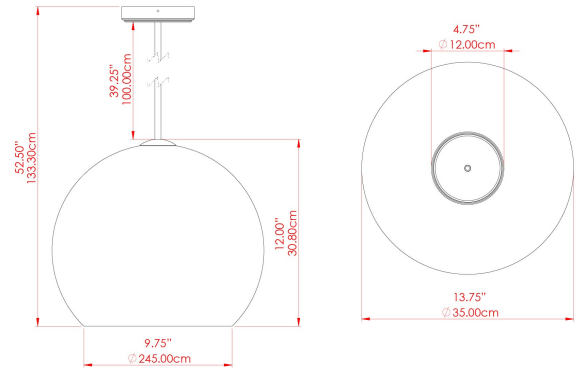

MATERIAL	Brass Steel
HEIGHT	37.5"
WIDTH DIAMETER	13.75"
LENGTH PROJECTION	n/a
WEIGHT	2.8 kg 6.3 lbs
LAMPHOLDER	E12
MAX WATTAGE	40W
VOLTAGE	110/120v
ENVIRONMENTAL RATING	Dry Location (IP20)
CLASS PROTECTION	Class I
SHADE	GL134
FLEX BAR CHAIN LENGTH	40"
CABLE TYPE	

FIXING BRACKET: MLWB17

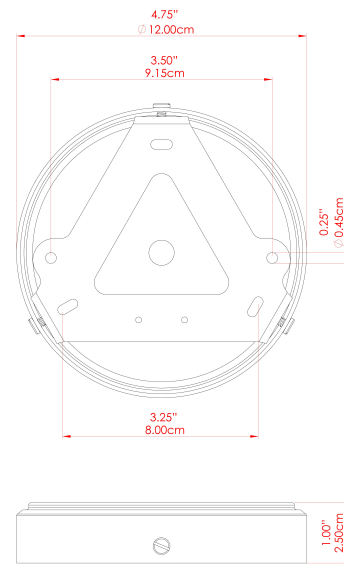

Product Notes:
 1) Bulbs not included. 2) Dimensions do not include bulbs. 3) All products are individually made-to-order and therefore may differ slightly within manufacturing tolerances. 4) Cable / chain can be shortened during installation. Longer cable / chain lengths available on request. 5) Additional color finishes may be available on request. 6) Twisted cable is not available for UL wired products. Round cable in black or brown only is supplied instead. 7) Refer to our website for a full list of terms and conditions.



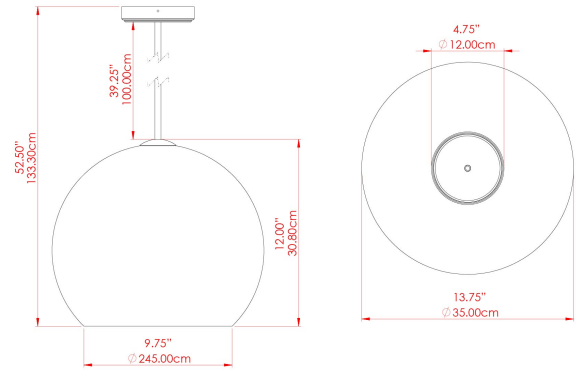

MATERIAL	Brass Steel
HEIGHT	37.5"
WIDTH DIAMETER	13.75"
LENGTH PROJECTION	n/a
WEIGHT	2.8 kg 6.3 lbs
LAMPHOLDER	E12
MAX WATTAGE	40W
VOLTAGE	110/120v
ENVIRONMENTAL RATING	Dry Location (IP20)
CLASS PROTECTION	Class I
SHADE	GL134
FLEX BAR CHAIN LENGTH	40"
CABLE TYPE	

FIXING BRACKET: MLWB17

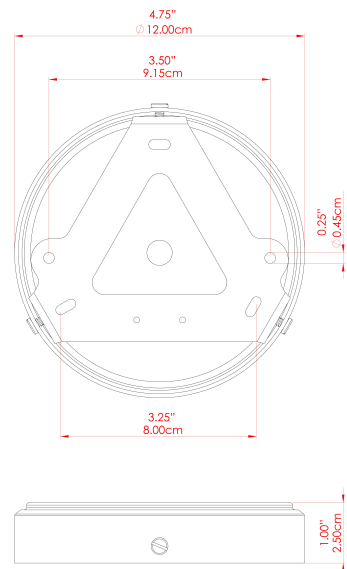

Product Notes:
 1) Bulbs not included. 2) Dimensions do not include bulbs. 3) All products are individually made-to-order and therefore may differ slightly within manufacturing tolerances. 4) Cable / chain can be shortened during installation. Longer cable / chain lengths available on request. 5) Additional color finishes may be available on request. 6) Twisted cable is not available for UL wired products. Round cable in black or brown only is supplied instead. 7) Refer to our website for a full list of terms and conditions.

