

SEVILLE Ceramic Table Lamp

MLCMTL037ANTBRS Antique Brass

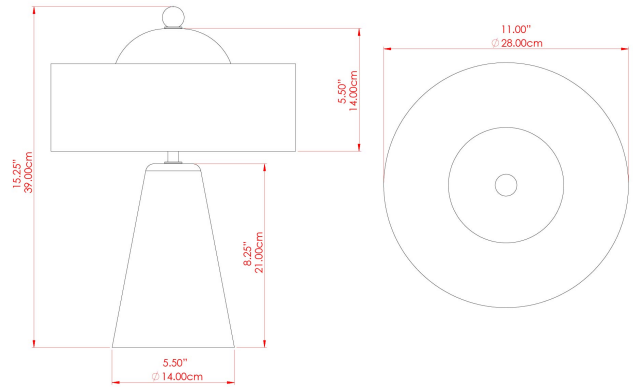

MATERIAL	Ceramic Brass
HEIGHT	15.75"
WIDTH DIAMETER	11"
LENGTH PROJECTION	n/a
WEIGHT	4.9 kg 10.8 lbs
LAMPHOLDER	G9
MAX WATTAGE	5W
VOLTAGE	110/120v
ENVIRONMENTAL RATING	Dry Location (IP20)
CLASS PROTECTION	Class I
SHADE	MLCS081
FLEX BAR CHAIN LENGTH	n/a
CABLE TYPE	MLCA002 Brown Fabric Braided Cable 2 Core Twisted

FIXING BRACKET: -



Product Notes:
 1) Bulbs not included. 2) Dimensions do not include bulbs. 3) All products are individually made-to-order and therefore may differ slightly within manufacturing tolerances. 4) Cable / chain can be shortened during installation. Longer cable / chain lengths available on request. 5) Additional color finishes may be available on request. 6) Twisted cable is not available for UL wired products. Round cable in black or brown only is supplied instead. 7) Refer to our website for a full list of terms and conditions.



SEVILLE Ceramic Table Lamp

MLCMTL037ANTSLV Antique Silver

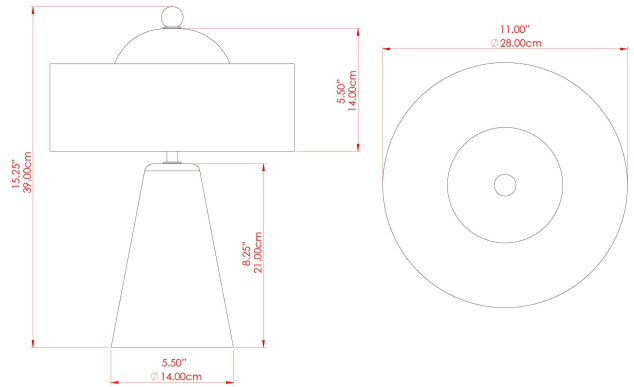

MATERIAL	Ceramic Brass
HEIGHT	15.75"
WIDTH DIAMETER	11"
LENGTH PROJECTION	n/a
WEIGHT	4.9 kg 10.8 lbs
LAMPHOLDER	G9
MAX WATTAGE	5W
VOLTAGE	110/120v
ENVIRONMENTAL RATING	Dry Location (IP20)
CLASS PROTECTION	Class I
SHADE	MLCS081
FLEX BAR CHAIN LENGTH	n/a
CABLE TYPE	MLCA001 Black Fabric Braided Cable 2 Core Twisted

FIXING BRACKET: -



Product Notes:
 1) Bulbs not included. 2) Dimensions do not include bulbs. 3) All products are individually made-to-order and therefore may differ slightly within manufacturing tolerances. 4) Cable / chain can be shortened during installation. Longer cable / chain lengths available on request. 5) Additional color finishes may be available on request. 6) Twisted cable is not available for UL wired products. Round cable in black or brown only is supplied instead. 7) Refer to our website for a full list of terms and conditions.





SEVILLE Ceramic Table Lamp

MLCMTL037PCMBK Matt Black

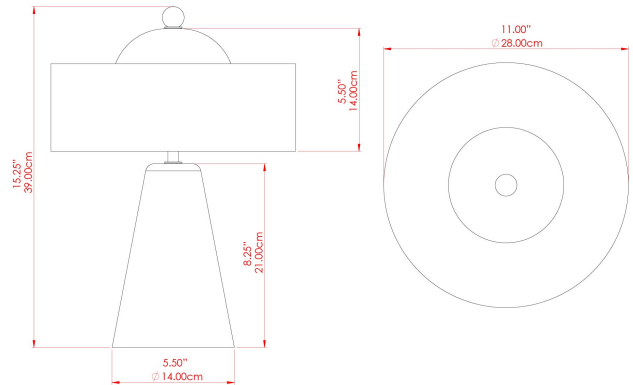

MATERIAL	Ceramic Brass
HEIGHT	15.75"
WIDTH DIAMETER	11"
LENGTH PROJECTION	n/a
WEIGHT	4.9 kg 10.8 lbs
LAMPHOLDER	G9
MAX WATTAGE	5W
VOLTAGE	110/120v
ENVIRONMENTAL RATING	Dry Location (IP20)
CLASS PROTECTION	Class I
SHADE	MLCS081
FLEX BAR CHAIN LENGTH	n/a
CABLE TYPE	MLCA001 Black Fabric Braided Cable 2 Core Twisted

FIXING BRACKET: -



Product Notes:
1) Bulbs not included. 2) Dimensions do not include bulbs. 3) All products are individually made-to-order and therefore may differ slightly within manufacturing tolerances. 4) Cable / chain can be shortened during installation. Longer cable / chain lengths available on request. 5) Additional color finishes may be available on request. 6) Twisted cable is not available for UL wired products. Round cable in black or brown only is supplied instead. 7) Refer to our website for a full list of terms and conditions.





SEVILLE Ceramic Table Lamp

MLCMTL037POLBRS Polished Brass

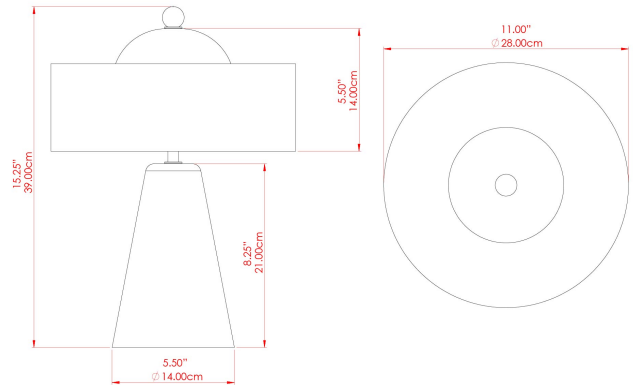

MATERIAL	Ceramic Brass	FIXING BRACKET: -
HEIGHT	15.75"	
WIDTH DIAMETER	11"	
LENGTH PROJECTION	n/a	
WEIGHT	4.9 kg 10.8 lbs	
LAMPHOLDER	G9	
MAX WATTAGE	5W	
VOLTAGE	110/120v	
ENVIRONMENTAL RATING	Dry Location (IP20)	
CLASS PROTECTION	Class I	
SHADE	MLCS081	
FLEX BAR CHAIN LENGTH	n/a	
CABLE TYPE	MLCA001 Black Fabric Braided Cable 2 Core Twisted	



WWW.MULLANLIGHTING.COM

Product Notes:

1) Bulbs not included. 2) Dimensions do not include bulbs. 3) All products are individually made-to-order and therefore may differ slightly within manufacturing tolerances. 4) Cable / chain can be shortened during installation. Longer cable / chain lengths available on request. 5) Additional color finishes may be available on request. 6) Twisted cable is not available for UL wired products. Round cable in black or brown only is supplied instead. 7) Refer to our website for a full list of terms and conditions.



SEVILLE Ceramic Table Lamp

MLCMTL037SATBRS Satin Brass

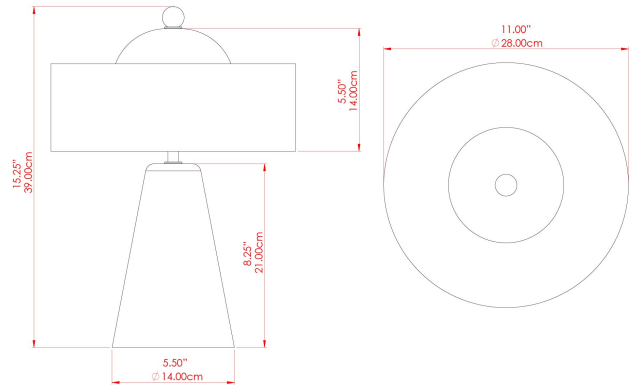

MATERIAL	Ceramic Brass
HEIGHT	15.75"
WIDTH DIAMETER	11"
LENGTH PROJECTION	n/a
WEIGHT	4.9 kg 10.8 lbs
LAMPHOLDER	G9
MAX WATTAGE	5W
VOLTAGE	110/120v
ENVIRONMENTAL RATING	Dry Location (IP20)
CLASS PROTECTION	Class I
SHADE	MLCS081
FLEX BAR CHAIN LENGTH	n/a
CABLE TYPE	MLCA001 Black Fabric Braided Cable 2 Core Twisted

FIXING BRACKET: -



Product Notes:
 1) Bulbs not included. 2) Dimensions do not include bulbs. 3) All products are individually made-to-order and therefore may differ slightly within manufacturing tolerances. 4) Cable / chain can be shortened during installation. Longer cable / chain lengths available on request. 5) Additional color finishes may be available on request. 6) Twisted cable is not available for UL wired products. Round cable in black or brown only is supplied instead. 7) Refer to our website for a full list of terms and conditions.

