

PRALI Ceramic Table Lamp

MLCMTL031ANTBRS Antique Brass

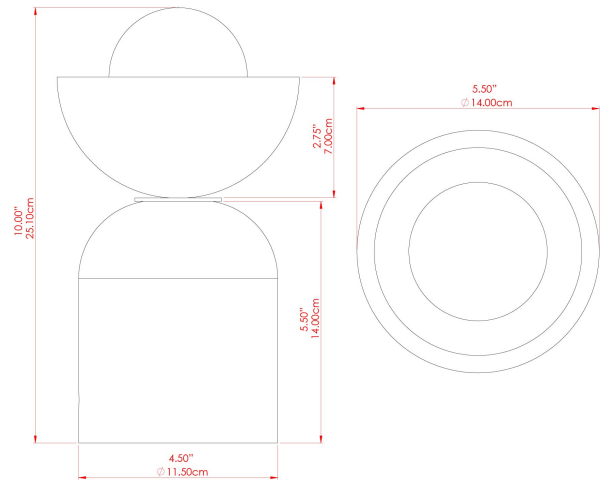

MATERIAL	Ceramic Brass Glass
HEIGHT	9.75"
WIDTH DIAMETER	5.5"
LENGTH PROJECTION	n/a
WEIGHT	1.7 kg 3.8 lbs
LAMPHOLDER	G9
MAX WATTAGE	6.5W
VOLTAGE	110/120v
ENVIRONMENTAL RATING	Dry Location (IP20)
CLASS PROTECTION	Class II
SHADE	MLL031 GL192 MLCS073
FLEX BAR CHAIN LENGTH	n/a
CABLE TYPE	MLCA047 Brown Fabric Braided Cable 2 Core Round

FIXING BRACKET: -



Product Notes:
 1) Bulbs not included. 2) Dimensions do not include bulbs. 3) All products are individually made-to-order and therefore may differ slightly within manufacturing tolerances. 4) Cable / chain can be shortened during installation. Longer cable / chain lengths available on request. 5) Additional color finishes may be available on request. 6) Twisted cable is not available for UL wired products. Round cable in black or brown only is supplied instead. 7) Refer to our website for a full list of terms and conditions.



PRALI Ceramic Table Lamp

MLCMTL031ANTBRACL Antique Brass

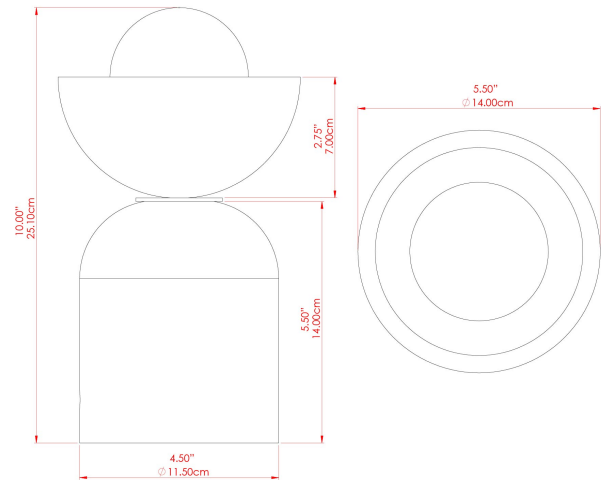

MATERIAL	Ceramic Brass Glass
HEIGHT	9.75"
WIDTH DIAMETER	5.5"
LENGTH PROJECTION	n/a
WEIGHT	1.7 kg 3.8 lbs
LAMPHOLDER	G9
MAX WATTAGE	6.5W
VOLTAGE	110/120v
ENVIRONMENTAL RATING	Dry Location (IP20)
CLASS PROTECTION	Class II
SHADE	MLL031 GL196 MLCS073
FLEX BAR CHAIN LENGTH	n/a
CABLE TYPE	MLCA047 Brown Fabric Braided Cable 2 Core Round

FIXING BRACKET: -



Product Notes:
 1) Bulbs not included. 2) Dimensions do not include bulbs. 3) All products are individually made-to-order and therefore may differ slightly within manufacturing tolerances. 4) Cable / chain can be shortened during installation. Longer cable / chain lengths available on request. 5) Additional color finishes may be available on request. 6) Twisted cable is not available for UL wired products. Round cable in black or brown only is supplied instead. 7) Refer to our website for a full list of terms and conditions.





PRALI Ceramic Table Lamp

MLCMTL031ANTBRSFR Antique Brass

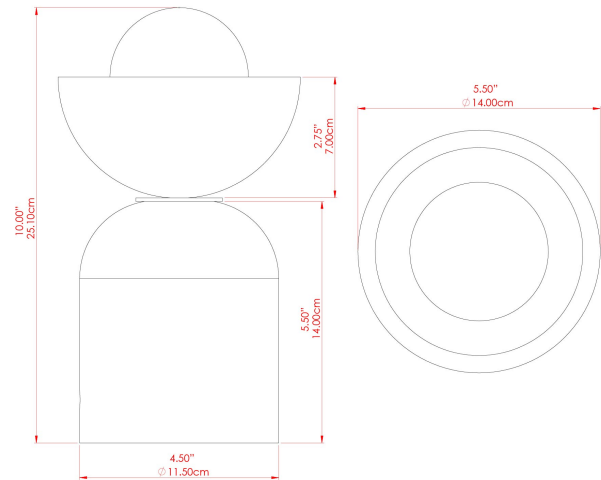

MATERIAL	Ceramic Brass Glass
HEIGHT	9.75"
WIDTH DIAMETER	5.5"
LENGTH PROJECTION	n/a
WEIGHT	1.7 kg 3.8 lbs
LAMPHOLDER	G9
MAX WATTAGE	6.5W
VOLTAGE	110/120v
ENVIRONMENTAL RATING	Dry Location (IP20)
CLASS PROTECTION	Class II
SHADE	MLL031 GL208 MLCS073
FLEX BAR CHAIN LENGTH	n/a
CABLE TYPE	MLCA047 Brown Fabric Braided Cable 2 Core Round

FIXING BRACKET: -



WWW.MULLANLIGHTING.COM

Product Notes:

1) Bulbs not included. 2) Dimensions do not include bulbs. 3) All products are individually made-to-order and therefore may differ slightly within manufacturing tolerances. 4) Cable / chain can be shortened during installation. Longer cable / chain lengths available on request. 5) Additional color finishes may be available on request. 6) Twisted cable is not available for UL wired products. Round cable in black or brown only is supplied instead. 7) Refer to our website for a full list of terms and conditions.



PRALI Ceramic Table Lamp

MLCMTL031ANTSLV Antique Silver

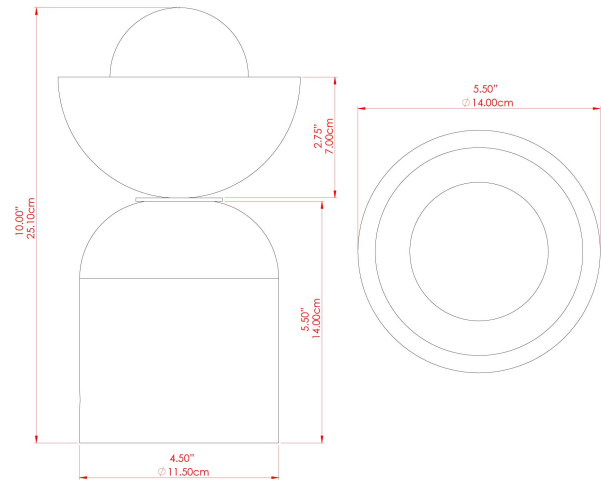

MATERIAL	Ceramic Brass Glass
HEIGHT	9.75"
WIDTH DIAMETER	5.5"
LENGTH PROJECTION	n/a
WEIGHT	1.7 kg 3.8 lbs
LAMPHOLDER	G9
MAX WATTAGE	6.5W
VOLTAGE	110/120v
ENVIRONMENTAL RATING	Dry Location (IP20)
CLASS PROTECTION	Class II
SHADE	MLL031 GL192 MLCS073
FLEX BAR CHAIN LENGTH	n/a
CABLE TYPE	MLCA028 Black Fabric Braided Cable 2 Core Round

FIXING BRACKET: -



Product Notes:
 1) Bulbs not included. 2) Dimensions do not include bulbs. 3) All products are individually made-to-order and therefore may differ slightly within manufacturing tolerances. 4) Cable / chain can be shortened during installation. Longer cable / chain lengths available on request. 5) Additional color finishes may be available on request. 6) Twisted cable is not available for UL wired products. Round cable in black or brown only is supplied instead. 7) Refer to our website for a full list of terms and conditions.





PRALI Ceramic Table Lamp

MLCMTL031ANTSLVCL Antique Silver

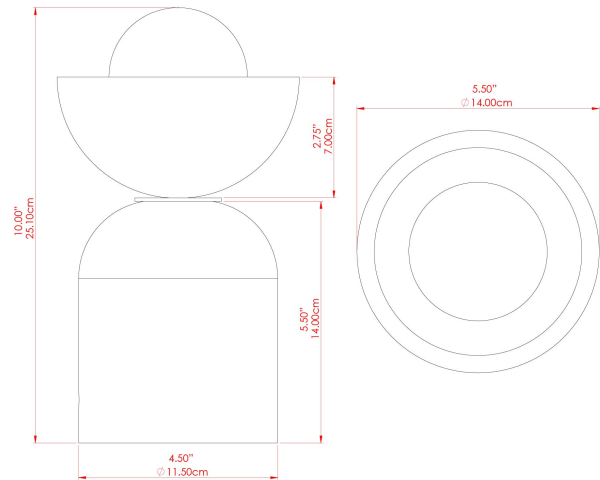

MATERIAL	Ceramic Brass Glass
HEIGHT	9.75"
WIDTH DIAMETER	5.5"
LENGTH PROJECTION	n/a
WEIGHT	1.7 kg 3.8 lbs
LAMPHOLDER	G9
MAX WATTAGE	6.5W
VOLTAGE	110/120v
ENVIRONMENTAL RATING	Dry Location (IP20)
CLASS PROTECTION	Class II
SHADE	MLL031 GL196 MLCS073
FLEX BAR CHAIN LENGTH	n/a
CABLE TYPE	MLCA028 Black Fabric Braided Cable 2 Core Round

FIXING BRACKET: -



Product Notes:
1) Bulbs not included. 2) Dimensions do not include bulbs. 3) All products are individually made-to-order and therefore may differ slightly within manufacturing tolerances. 4) Cable / chain can be shortened during installation. Longer cable / chain lengths available on request. 5) Additional color finishes may be available on request. 6) Twisted cable is not available for UL wired products. Round cable in black or brown only is supplied instead. 7) Refer to our website for a full list of terms and conditions.



PRALI Ceramic Table Lamp

MLCMTL031ANTSLVFR Antique Silver

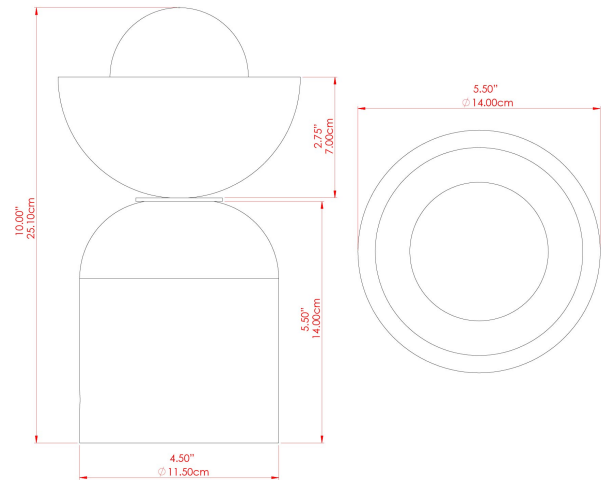

MATERIAL	Ceramic Brass Glass
HEIGHT	9.75"
WIDTH DIAMETER	5.5"
LENGTH PROJECTION	n/a
WEIGHT	1.7 kg 3.8 lbs
LAMPHOLDER	G9
MAX WATTAGE	6.5W
VOLTAGE	110/120v
ENVIRONMENTAL RATING	Dry Location (IP20)
CLASS PROTECTION	Class II
SHADE	MLL031 GL208 MLCS073
FLEX BAR CHAIN LENGTH	n/a
CABLE TYPE	MLCA028 Black Fabric Braided Cable 2 Core Round

FIXING BRACKET: -



Product Notes:
 1) Bulbs not included. 2) Dimensions do not include bulbs. 3) All products are individually made-to-order and therefore may differ slightly within manufacturing tolerances. 4) Cable / chain can be shortened during installation. Longer cable / chain lengths available on request. 5) Additional color finishes may be available on request. 6) Twisted cable is not available for UL wired products. Round cable in black or brown only is supplied instead. 7) Refer to our website for a full list of terms and conditions.





PRALI Ceramic Table Lamp

MLCMTL031PCMBK Matt Black

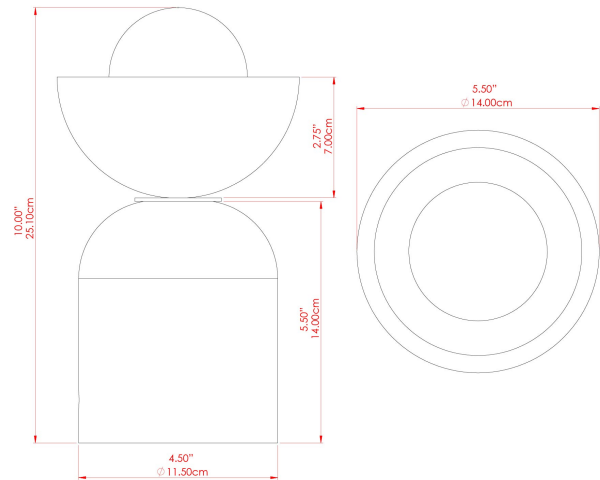

MATERIAL	Ceramic Brass Glass
HEIGHT	9.75"
WIDTH DIAMETER	5.5"
LENGTH PROJECTION	n/a
WEIGHT	1.7 kg 3.8 lbs
LAMPHOLDER	G9
MAX WATTAGE	6.5W
VOLTAGE	110/120v
ENVIRONMENTAL RATING	Dry Location (IP20)
CLASS PROTECTION	Class II
SHADE	MLL031 GL192 MLCS073
FLEX BAR CHAIN LENGTH	n/a
CABLE TYPE	MLCA028 Black Fabric Braided Cable 2 Core Round

FIXING BRACKET: -



Product Notes:
1) Bulbs not included. 2) Dimensions do not include bulbs. 3) All products are individually made-to-order and therefore may differ slightly within manufacturing tolerances. 4) Cable / chain can be shortened during installation. Longer cable / chain lengths available on request. 5) Additional color finishes may be available on request. 6) Twisted cable is not available for UL wired products. Round cable in black or brown only is supplied instead. 7) Refer to our website for a full list of terms and conditions.





PRALI Ceramic Table Lamp

MLCMTL031PCMBKCL Matt Black

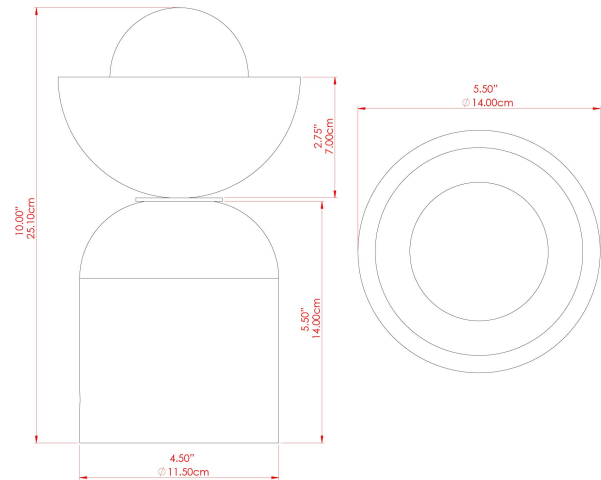

MATERIAL	Ceramic Brass Glass
HEIGHT	9.75"
WIDTH DIAMETER	5.5"
LENGTH PROJECTION	n/a
WEIGHT	1.7 kg 3.8 lbs
LAMPHOLDER	G9
MAX WATTAGE	6.5W
VOLTAGE	110/120v
ENVIRONMENTAL RATING	Dry Location (IP20)
CLASS PROTECTION	Class II
SHADE	MLL031 GL196 MLCS073
FLEX BAR CHAIN LENGTH	n/a
CABLE TYPE	MLCA028 Black Fabric Braided Cable 2 Core Round

FIXING BRACKET: -



WWW.MULLANLIGHTING.COM

Product Notes:

1) Bulbs not included. 2) Dimensions do not include bulbs. 3) All products are individually made-to-order and therefore may differ slightly within manufacturing tolerances. 4) Cable / chain can be shortened during installation. Longer cable / chain lengths available on request. 5) Additional color finishes may be available on request. 6) Twisted cable is not available for UL wired products. Round cable in black or brown only is supplied instead. 7) Refer to our website for a full list of terms and conditions.





PRALI Ceramic Table Lamp

MLCMTL031PCMBKFR Matt Black

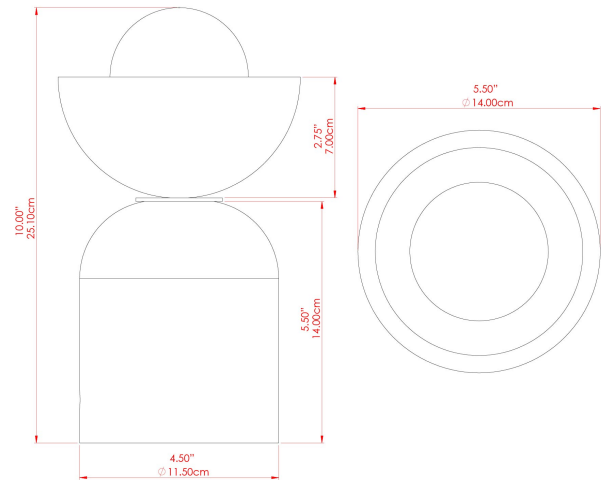

MATERIAL	Ceramic Brass Glass
HEIGHT	9.75"
WIDTH DIAMETER	5.5"
LENGTH PROJECTION	n/a
WEIGHT	1.7 kg 3.8 lbs
LAMPHOLDER	G9
MAX WATTAGE	6.5W
VOLTAGE	110/120v
ENVIRONMENTAL RATING	Dry Location (IP20)
CLASS PROTECTION	Class II
SHADE	MLL031 GL208 MLCS073
FLEX BAR CHAIN LENGTH	n/a
CABLE TYPE	MLCA028 Black Fabric Braided Cable 2 Core Round

FIXING BRACKET: -



WWW.MULLANLIGHTING.COM

Product Notes:

1) Bulbs not included. 2) Dimensions do not include bulbs. 3) All products are individually made-to-order and therefore may differ slightly within manufacturing tolerances. 4) Cable / chain can be shortened during installation. Longer cable / chain lengths available on request. 5) Additional color finishes may be available on request. 6) Twisted cable is not available for UL wired products. Round cable in black or brown only is supplied instead. 7) Refer to our website for a full list of terms and conditions.





PRALI Ceramic Table Lamp

MLCMTL031POLBRS Polished Brass

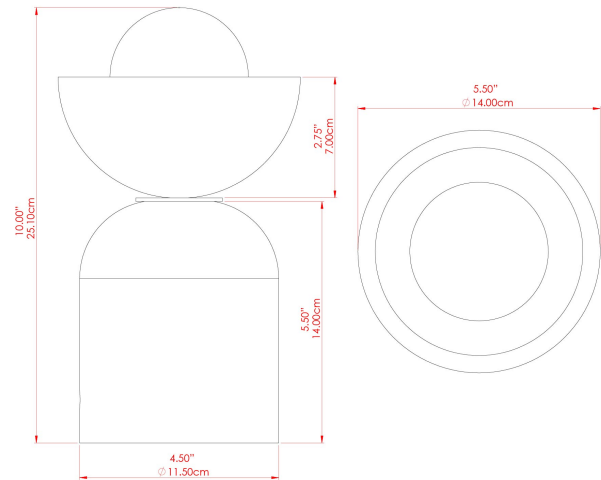

MATERIAL	Ceramic Brass Glass
HEIGHT	9.75"
WIDTH DIAMETER	5.5"
LENGTH PROJECTION	n/a
WEIGHT	1.7 kg 3.8 lbs
LAMPHOLDER	G9
MAX WATTAGE	6.5W
VOLTAGE	110/120v
ENVIRONMENTAL RATING	Dry Location (IP20)
CLASS PROTECTION	Class II
SHADE	MLL031 GL192 MLCS073
FLEX BAR CHAIN LENGTH	n/a
CABLE TYPE	MLCA028 Black Fabric Braided Cable 2 Core Round

FIXING BRACKET: -



Product Notes:

1) Bulbs not included. 2) Dimensions do not include bulbs. 3) All products are individually made-to-order and therefore may differ slightly within manufacturing tolerances. 4) Cable / chain can be shortened during installation. Longer cable / chain lengths available on request. 5) Additional color finishes may be available on request. 6) Twisted cable is not available for UL wired products. Round cable in black or brown only is supplied instead. 7) Refer to our website for a full list of terms and conditions.





PRALI Ceramic Table Lamp

MLCMTL031POLBRSCl Polished Brass

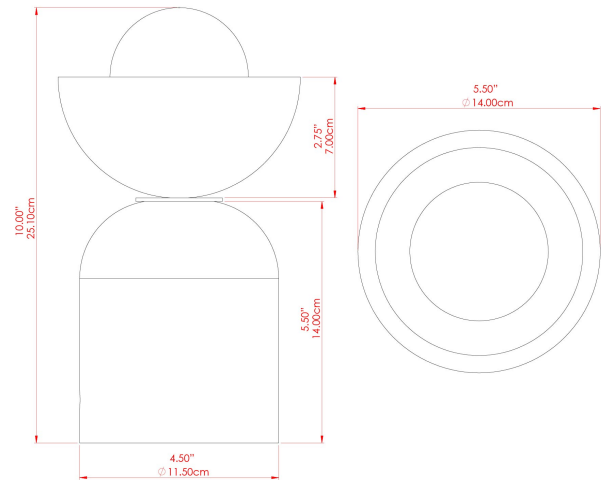

MATERIAL	Ceramic Brass Glass
HEIGHT	9.75"
WIDTH DIAMETER	5.5"
LENGTH PROJECTION	n/a
WEIGHT	1.7 kg 3.8 lbs
LAMPHOLDER	G9
MAX WATTAGE	6.5W
VOLTAGE	110/120v
ENVIRONMENTAL RATING	Dry Location (IP20)
CLASS PROTECTION	Class II
SHADE	MLL031 GL196 MLCS073
FLEX BAR CHAIN LENGTH	n/a
CABLE TYPE	MLCA028 Black Fabric Braided Cable 2 Core Round

FIXING BRACKET: -



Product Notes:
1) Bulbs not included. 2) Dimensions do not include bulbs. 3) All products are individually made-to-order and therefore may differ slightly within manufacturing tolerances. 4) Cable / chain can be shortened during installation. Longer cable / chain lengths available on request. 5) Additional color finishes may be available on request. 6) Twisted cable is not available for UL wired products. Round cable in black or brown only is supplied instead. 7) Refer to our website for a full list of terms and conditions.





PRALI Ceramic Table Lamp

MLCMTL031POLBRSFR Polished Brass

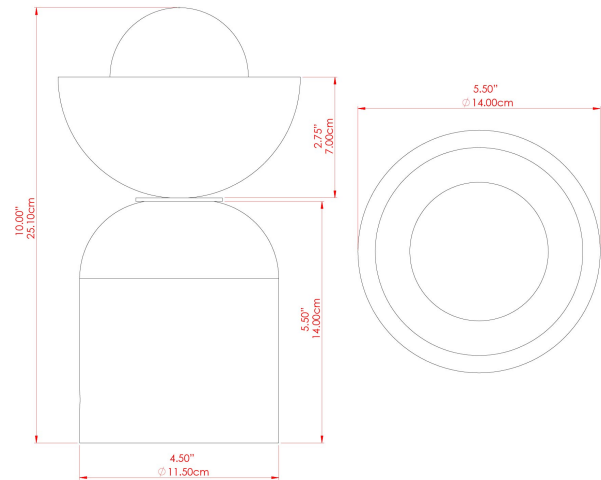

MATERIAL	Ceramic Brass Glass
HEIGHT	9.75"
WIDTH DIAMETER	5.5"
LENGTH PROJECTION	n/a
WEIGHT	1.7 kg 3.8 lbs
LAMPHOLDER	G9
MAX WATTAGE	6.5W
VOLTAGE	110/120v
ENVIRONMENTAL RATING	Dry Location (IP20)
CLASS PROTECTION	Class II
SHADE	MLL031 GL208 MLCS073
FLEX BAR CHAIN LENGTH	n/a
CABLE TYPE	MLCA028 Black Fabric Braided Cable 2 Core Round

FIXING BRACKET: -



Product Notes:
1) Bulbs not included. 2) Dimensions do not include bulbs. 3) All products are individually made-to-order and therefore may differ slightly within manufacturing tolerances. 4) Cable / chain can be shortened during installation. Longer cable / chain lengths available on request. 5) Additional color finishes may be available on request. 6) Twisted cable is not available for UL wired products. Round cable in black or brown only is supplied instead. 7) Refer to our website for a full list of terms and conditions.



PRALI Ceramic Table Lamp

MLCMTL031SATBRS Satin Brass

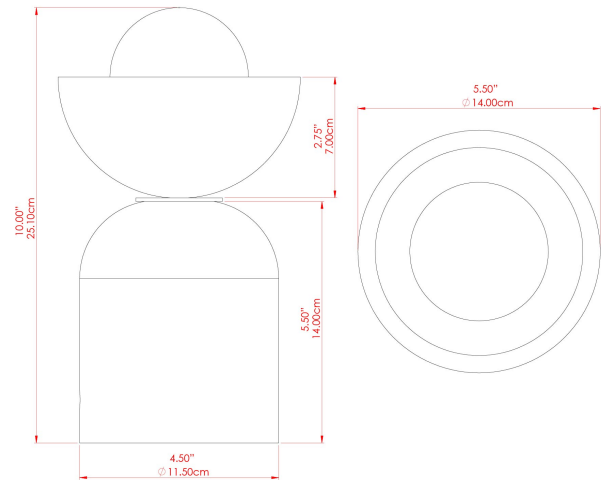

MATERIAL	Ceramic Brass Glass
HEIGHT	9.75"
WIDTH DIAMETER	5.5"
LENGTH PROJECTION	n/a
WEIGHT	1.7 kg 3.8 lbs
LAMPHOLDER	G9
MAX WATTAGE	6.5W
VOLTAGE	110/120v
ENVIRONMENTAL RATING	Dry Location (IP20)
CLASS PROTECTION	Class II
SHADE	MLL031 GL192 MLCS073
FLEX BAR CHAIN LENGTH	n/a
CABLE TYPE	MLCA028 Black Fabric Braided Cable 2 Core Round

FIXING BRACKET: -



Product Notes:
 1) Bulbs not included. 2) Dimensions do not include bulbs. 3) All products are individually made-to-order and therefore may differ slightly within manufacturing tolerances. 4) Cable / chain can be shortened during installation. Longer cable / chain lengths available on request. 5) Additional color finishes may be available on request. 6) Twisted cable is not available for UL wired products. Round cable in black or brown only is supplied instead. 7) Refer to our website for a full list of terms and conditions.



PRALI Ceramic Table Lamp

MLCMTL031SATBRSL Satin Brass

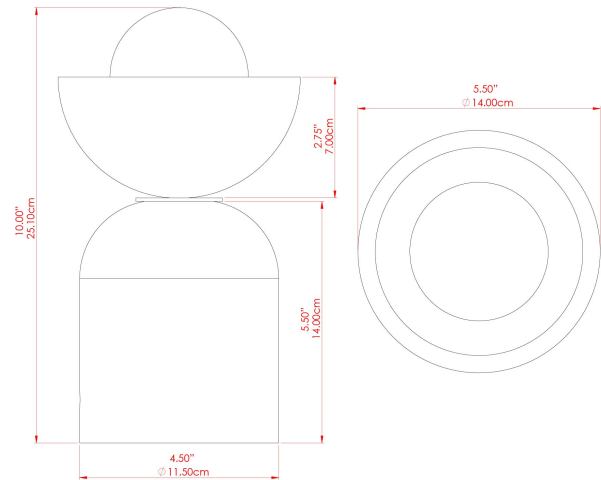

MATERIAL	Ceramic Brass Glass
HEIGHT	9.75"
WIDTH DIAMETER	5.5"
LENGTH PROJECTION	n/a
WEIGHT	1.7 kg 3.8 lbs
LAMPHOLDER	G9
MAX WATTAGE	6.5W
VOLTAGE	110/120v
ENVIRONMENTAL RATING	Dry Location (IP20)
CLASS PROTECTION	Class II
SHADE	MLL031 GL196 MLCS073
FLEX BAR CHAIN LENGTH	n/a
CABLE TYPE	MLCA028 Black Fabric Braided Cable 2 Core Round

FIXING BRACKET: -



Product Notes:
 1) Bulbs not included. 2) Dimensions do not include bulbs. 3) All products are individually made-to-order and therefore may differ slightly within manufacturing tolerances. 4) Cable / chain can be shortened during installation. Longer cable / chain lengths available on request. 5) Additional color finishes may be available on request. 6) Twisted cable is not available for UL wired products. Round cable in black or brown only is supplied instead. 7) Refer to our website for a full list of terms and conditions.



PRALI Ceramic Table Lamp

MLCMTL031SATBRSFR Satin Brass

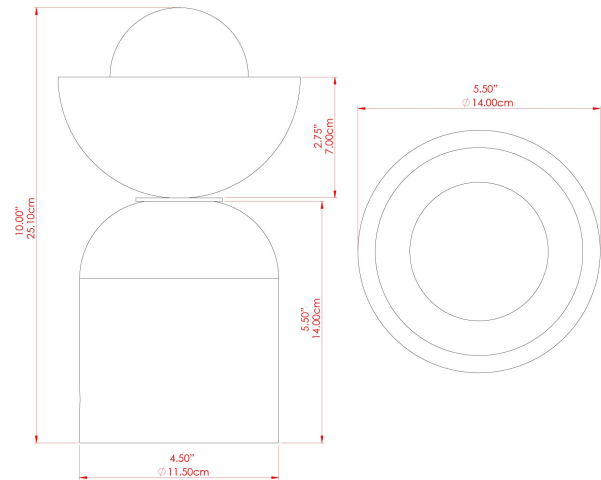

MATERIAL	Ceramic Brass Glass
HEIGHT	9.75"
WIDTH DIAMETER	5.5"
LENGTH PROJECTION	n/a
WEIGHT	1.7 kg 3.8 lbs
LAMPHOLDER	G9
MAX WATTAGE	6.5W
VOLTAGE	110/120v
ENVIRONMENTAL RATING	Dry Location (IP20)
CLASS PROTECTION	Class II
SHADE	MLL031 GL208 MLCS073
FLEX BAR CHAIN LENGTH	n/a
CABLE TYPE	MLCA028 Black Fabric Braided Cable 2 Core Round

FIXING BRACKET: -



Product Notes:
 1) Bulbs not included. 2) Dimensions do not include bulbs. 3) All products are individually made-to-order and therefore may differ slightly within manufacturing tolerances. 4) Cable / chain can be shortened during installation. Longer cable / chain lengths available on request. 5) Additional color finishes may be available on request. 6) Twisted cable is not available for UL wired products. Round cable in black or brown only is supplied instead. 7) Refer to our website for a full list of terms and conditions.

