

AMANITA Ceramic Table Lamp

MLCMTL030ANTBRS Antique Brass

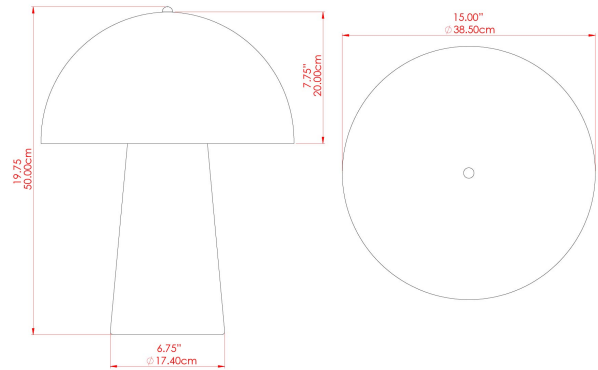

MATERIAL	Brass Ceramic
HEIGHT	19.75"
WIDTH DIAMETER	15.25"
LENGTH PROJECTION	n/a
WEIGHT	7.8 kg 17.3 lbs
LAMPHOLDER	G9
MAX WATTAGE	6.5W
VOLTAGE	110/120v
ENVIRONMENTAL RATING	Dry Location (IP20)
CLASS PROTECTION	Class I
SHADE	MLCS069
FLEX BAR CHAIN LENGTH	n/a
CABLE TYPE	MLCA046 Brown Fabric Braided Cable 3 Core Round

FIXING BRACKET: -



Product Notes:
 1) Bulbs not included. 2) Dimensions do not include bulbs. 3) All products are individually made-to-order and therefore may differ slightly within manufacturing tolerances. 4) Cable / chain can be shortened during installation. Longer cable / chain lengths available on request. 5) Additional color finishes may be available on request. 6) Twisted cable is not available for UL wired products. Round cable in black or brown only is supplied instead. 7) Refer to our website for a full list of terms and conditions.



AMANITA Ceramic Table Lamp

MLCMTL030ANTSLV Antique Silver

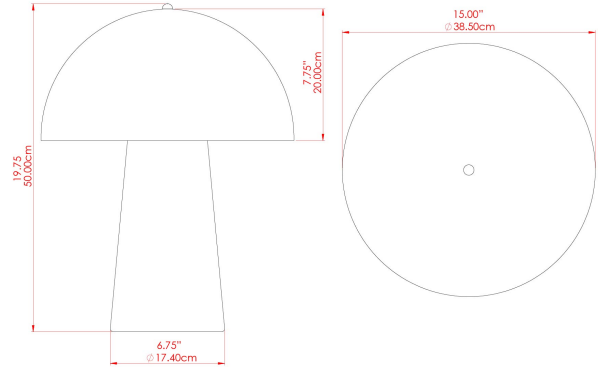

MATERIAL	Brass Ceramic
HEIGHT	19.75"
WIDTH DIAMETER	15.25"
LENGTH PROJECTION	n/a
WEIGHT	7.8 kg 17.3 lbs
LAMPHOLDER	G9
MAX WATTAGE	6.5W
VOLTAGE	110/120v
ENVIRONMENTAL RATING	Dry Location (IP20)
CLASS PROTECTION	Class I
SHADE	MLCS069
FLEX BAR CHAIN LENGTH	n/a
CABLE TYPE	MLCA029 Black Fabric Braided Cable 3 Core Round

FIXING BRACKET: -



Product Notes:
 1) Bulbs not included. 2) Dimensions do not include bulbs. 3) All products are individually made-to-order and therefore may differ slightly within manufacturing tolerances. 4) Cable / chain can be shortened during installation. Longer cable / chain lengths available on request. 5) Additional color finishes may be available on request. 6) Twisted cable is not available for UL wired products. Round cable in black or brown only is supplied instead. 7) Refer to our website for a full list of terms and conditions.





AMANITA Ceramic Table Lamp

MLCMTL030PCMBK Matt Black

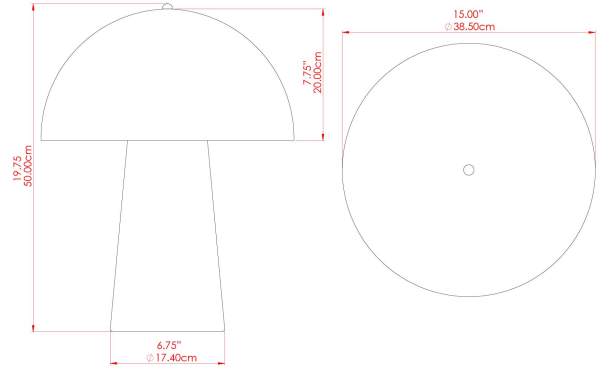

MATERIAL	Brass Ceramic
HEIGHT	19.75"
WIDTH DIAMETER	15.25"
LENGTH PROJECTION	n/a
WEIGHT	7.9 kg 17.5 lbs
LAMPHOLDER	G9
MAX WATTAGE	6.5W
VOLTAGE	110/120v
ENVIRONMENTAL RATING	Dry Location (IP20)
CLASS PROTECTION	Class I
SHADE	MLCS069
FLEX BAR CHAIN LENGTH	n/a
CABLE TYPE	MLCA029 Black Fabric Braided Cable 3 Core Round

FIXING BRACKET: -



WWW.MULLANLIGHTING.COM

Product Notes:

1) Bulbs not included. 2) Dimensions do not include bulbs. 3) All products are individually made-to-order and therefore may differ slightly within manufacturing tolerances. 4) Cable / chain can be shortened during installation. Longer cable / chain lengths available on request. 5) Additional color finishes may be available on request. 6) Twisted cable is not available for UL wired products. Round cable in black or brown only is supplied instead. 7) Refer to our website for a full list of terms and conditions.





AMANITA Ceramic Table Lamp

MLCMTL030POLBRS Polished Brass

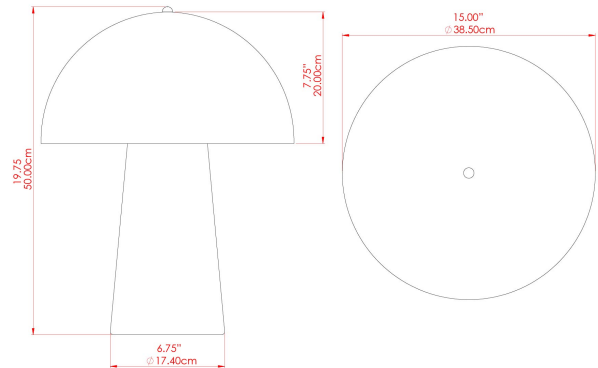

MATERIAL	Brass Ceramic
HEIGHT	19.75"
WIDTH DIAMETER	15.25"
LENGTH PROJECTION	n/a
WEIGHT	7.8 kg 17.3 lbs
LAMPHOLDER	G9
MAX WATTAGE	6.5W
VOLTAGE	110/120v
ENVIRONMENTAL RATING	Dry Location (IP20)
CLASS PROTECTION	Class I
SHADE	MLCS069
FLEX BAR CHAIN LENGTH	n/a
CABLE TYPE	MLCA029 Black Fabric Braided Cable 3 Core Round

FIXING BRACKET: -



WWW.MULLANLIGHTING.COM

Product Notes:

1) Bulbs not included. 2) Dimensions do not include bulbs. 3) All products are individually made-to-order and therefore may differ slightly within manufacturing tolerances. 4) Cable / chain can be shortened during installation. Longer cable / chain lengths available on request. 5) Additional color finishes may be available on request. 6) Twisted cable is not available for UL wired products. Round cable in black or brown only is supplied instead. 7) Refer to our website for a full list of terms and conditions.



AMANITA Ceramic Table Lamp

MLCMTL030SATBRS Satin Brass

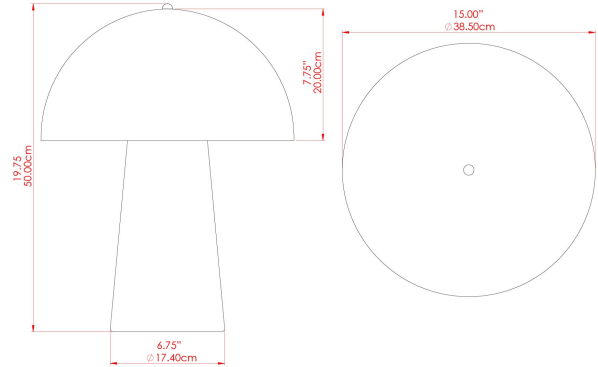

MATERIAL	Brass Ceramic
HEIGHT	19.75"
WIDTH DIAMETER	15.25"
LENGTH PROJECTION	n/a
WEIGHT	7.8 kg 17.3 lbs
LAMPHOLDER	G9
MAX WATTAGE	6.5W
VOLTAGE	110/120v
ENVIRONMENTAL RATING	Dry Location (IP20)
CLASS PROTECTION	Class I
SHADE	MLCS069
FLEX BAR CHAIN LENGTH	n/a
CABLE TYPE	MLCA029 Black Fabric Braided Cable 3 Core Round

FIXING BRACKET: -



WWW.MULLANLIGHTING.COM

Product Notes:

1) Bulbs not included. 2) Dimensions do not include bulbs. 3) All products are individually made-to-order and therefore may differ slightly within manufacturing tolerances. 4) Cable / chain can be shortened during installation. Longer cable / chain lengths available on request. 5) Additional color finishes may be available on request. 6) Twisted cable is not available for UL wired products. Round cable in black or brown only is supplied instead. 7) Refer to our website for a full list of terms and conditions.

