

CASSIA Ceramic Table Lamp

MLCMTL017ANTBRS Antique Brass

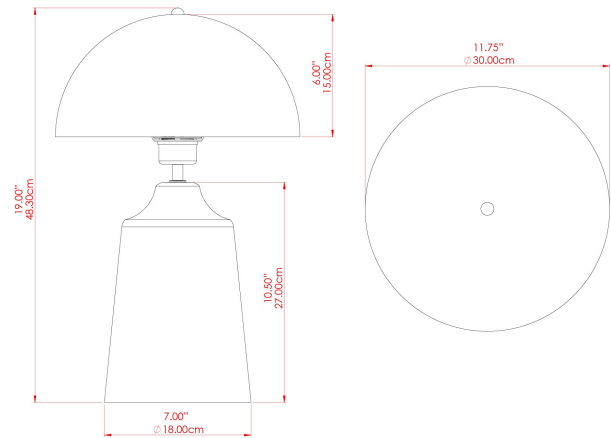

MATERIAL	Brass
HEIGHT	19.75"
WIDTH DIAMETER	11.75"
LENGTH PROJECTION	n/a
WEIGHT	4.2 kg 9.3 lbs
LAMPHOLDER	E26
MAX WATTAGE	40W
VOLTAGE	110/120v
ENVIRONMENTAL RATING	Dry Location (IP20)
CLASS PROTECTION	Class II
SHADE	-
FLEX BAR CHAIN LENGTH	n/a
CABLE TYPE	MLCA028 Black Fabric Braided Cable 2 Core Round

FIXING BRACKET: -



Product Notes:
 1) Bulbs not included. 2) Dimensions do not include bulbs. 3) All products are individually made-to-order and therefore may differ slightly within manufacturing tolerances. 4) Cable / chain can be shortened during installation. Longer cable / chain lengths available on request. 5) Additional color finishes may be available on request. 6) Twisted cable is not available for UL wired products. Round cable in black or brown only is supplied instead. 7) Refer to our website for a full list of terms and conditions.





CASSIA Ceramic Table Lamp

MLCMTL017ANTSLV Antique Silver

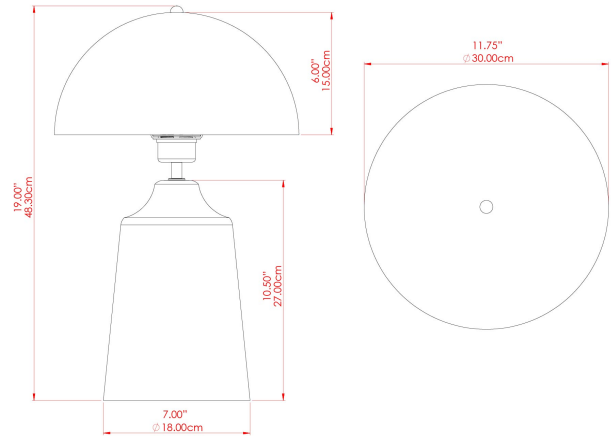

MATERIAL	Brass
HEIGHT	19.75"
WIDTH DIAMETER	11.75"
LENGTH PROJECTION	n/a
WEIGHT	4.2 kg 9.3 lbs
LAMPHOLDER	E26
MAX WATTAGE	40W
VOLTAGE	110/120v
ENVIRONMENTAL RATING	Dry Location (IP20)
CLASS PROTECTION	Class II
SHADE	-
FLEX BAR CHAIN LENGTH	n/a
CABLE TYPE	MLCA047 Brown Fabric Braided Cable 2 Core Round

FIXING BRACKET: -



WWW.MULLANLIGHTING.COM

Product Notes:

1) Bulbs not included. 2) Dimensions do not include bulbs. 3) All products are individually made-to-order and therefore may differ slightly within manufacturing tolerances. 4) Cable / chain can be shortened during installation. Longer cable / chain lengths available on request. 5) Additional color finishes may be available on request. 6) Twisted cable is not available for UL wired products. Round cable in black or brown only is supplied instead. 7) Refer to our website for a full list of terms and conditions.





CASSIA Ceramic Table Lamp

MLCMTL017PCMBK Matt Black

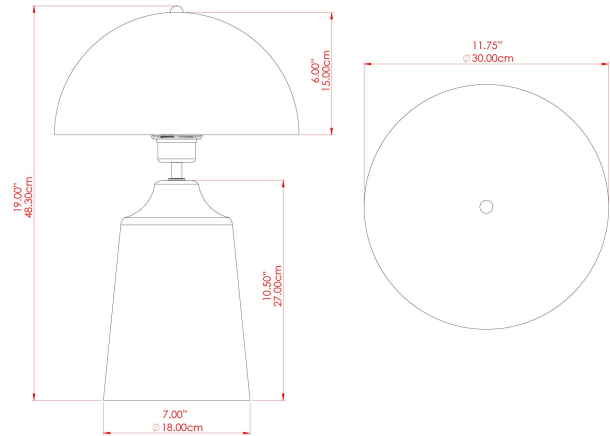

MATERIAL	Brass	FIXING BRACKET: -
HEIGHT	19.75"	
WIDTH DIAMETER	11.75"	
LENGTH PROJECTION	n/a	
WEIGHT	4.2 kg 9.3 lbs	
LAMPHOLDER	E26	
MAX WATTAGE	40W	
VOLTAGE	110/120v	
ENVIRONMENTAL RATING	Dry Location (IP20)	
CLASS PROTECTION	Class II	
SHADE	-	
FLEX BAR CHAIN LENGTH	n/a	
CABLE TYPE	MLCA028 Black Fabric Braided Cable 2 Core Round	



Product Notes:
1) Bulbs not included. 2) Dimensions do not include bulbs. 3) All products are individually made-to-order and therefore may differ slightly within manufacturing tolerances. 4) Cable / chain can be shortened during installation. Longer cable / chain lengths available on request. 5) Additional color finishes may be available on request. 6) Twisted cable is not available for UL wired products. Round cable in black or brown only is supplied instead. 7) Refer to our website for a full list of terms and conditions.





CASSIA Ceramic Table Lamp

MLCMTL017POLBRS Polished Brass

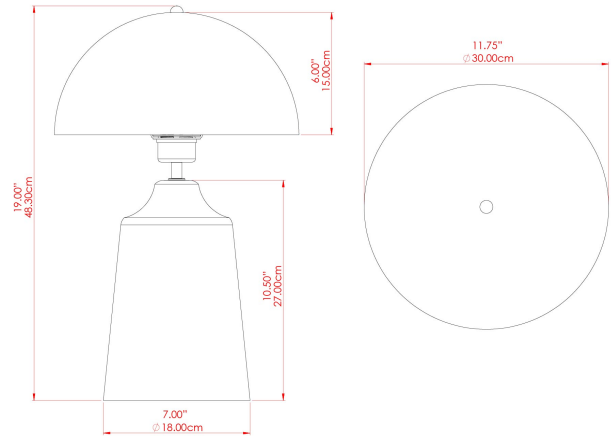

MATERIAL	Brass	FIXING BRACKET: -
HEIGHT	19.75"	
WIDTH DIAMETER	11.75"	
LENGTH PROJECTION	n/a	
WEIGHT	4.2 kg 9.3 lbs	
LAMPHOLDER	E26	
MAX WATTAGE	40W	
VOLTAGE	110/120v	
ENVIRONMENTAL RATING	Dry Location (IP20)	
CLASS PROTECTION	Class II	
SHADE	-	
FLEX BAR CHAIN LENGTH	n/a	
CABLE TYPE	MLCA028 Black Fabric Braided Cable 2 Core Round	



Product Notes:
1) Bulbs not included. 2) Dimensions do not include bulbs. 3) All products are individually made-to-order and therefore may differ slightly within manufacturing tolerances. 4) Cable / chain can be shortened during installation. Longer cable / chain lengths available on request. 5) Additional color finishes may be available on request. 6) Twisted cable is not available for UL wired products. Round cable in black or brown only is supplied instead. 7) Refer to our website for a full list of terms and conditions.





CASSIA Ceramic Table Lamp

MLCMTL017SATBRS Satin Brass

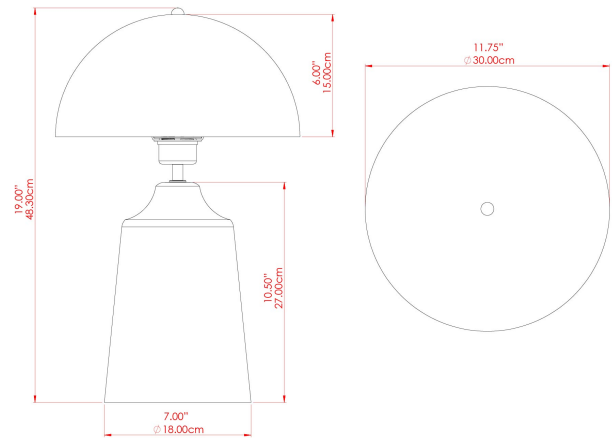

MATERIAL	Brass
HEIGHT	19.75"
WIDTH DIAMETER	11.75"
LENGTH PROJECTION	n/a
WEIGHT	4.2 kg 9.3 lbs
LAMPHOLDER	E26
MAX WATTAGE	40W
VOLTAGE	110/120v
ENVIRONMENTAL RATING	Dry Location (IP20)
CLASS PROTECTION	Class II
SHADE	-
FLEX BAR CHAIN LENGTH	n/a
CABLE TYPE	MLCA028 Black Fabric Braided Cable 2 Core Round

FIXING BRACKET: -



WWW.MULLANLIGHTING.COM

Product Notes:

1) Bulbs not included. 2) Dimensions do not include bulbs. 3) All products are individually made-to-order and therefore may differ slightly within manufacturing tolerances. 4) Cable / chain can be shortened during installation. Longer cable / chain lengths available on request. 5) Additional color finishes may be available on request. 6) Twisted cable is not available for UL wired products. Round cable in black or brown only is supplied instead. 7) Refer to our website for a full list of terms and conditions.

