

LAWSON Ceramic Table Lamp

MLCMTL016ANTBRS Antique Brass

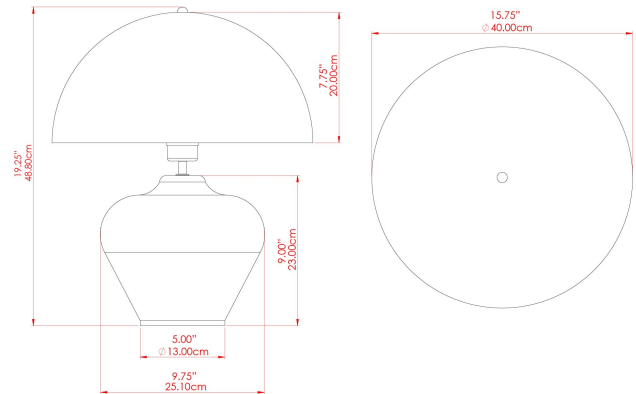

MATERIAL	Brass
HEIGHT	18.5"
WIDTH DIAMETER	15.75"
LENGTH PROJECTION	n/a
WEIGHT	4.8 kg 10.5 lbs
LAMPHOLDER	E26
MAX WATTAGE	40W
VOLTAGE	110/120v
ENVIRONMENTAL RATING	Dry Location (IP20)
CLASS PROTECTION	Class II
SHADE	-
FLEX BAR CHAIN LENGTH	n/a
CABLE TYPE	MLCA028 Black Fabric Braided Cable 2 Core Round

FIXING BRACKET: -



Product Notes:
 1) Bulbs not included. 2) Dimensions do not include bulbs. 3) All products are individually made-to-order and therefore may differ slightly within manufacturing tolerances. 4) Cable / chain can be shortened during installation. Longer cable / chain lengths available on request. 5) Additional color finishes may be available on request. 6) Twisted cable is not available for UL wired products. Round cable in black or brown only is supplied instead. 7) Refer to our website for a full list of terms and conditions.





LAWSON Ceramic Table Lamp

MLCMTL016ANTSLV Antique Silver

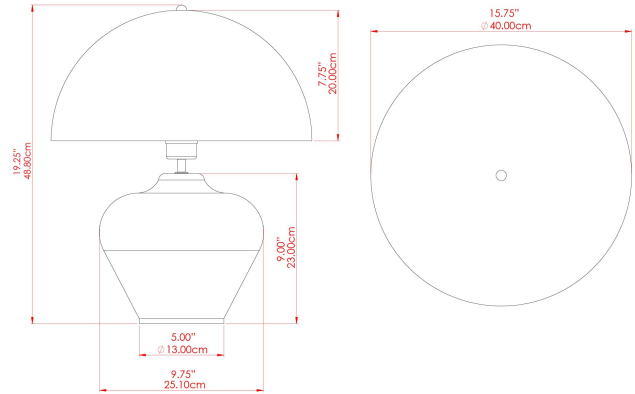

MATERIAL	Brass
HEIGHT	18.5"
WIDTH DIAMETER	15.75"
LENGTH PROJECTION	n/a
WEIGHT	4.8 kg 10.5 lbs
LAMPHOLDER	E26
MAX WATTAGE	40W
VOLTAGE	110/120v
ENVIRONMENTAL RATING	Dry Location (IP20)
CLASS PROTECTION	Class II
SHADE	-
FLEX BAR CHAIN LENGTH	n/a
CABLE TYPE	MLCA047 Brown Fabric Braided Cable 2 Core Round

FIXING BRACKET: -



Product Notes:

1) Bulbs not included. 2) Dimensions do not include bulbs. 3) All products are individually made-to-order and therefore may differ slightly within manufacturing tolerances. 4) Cable / chain can be shortened during installation. Longer cable / chain lengths available on request. 5) Additional color finishes may be available on request. 6) Twisted cable is not available for UL wired products. Round cable in black or brown only is supplied instead. 7) Refer to our website for a full list of terms and conditions.





LAWSON Ceramic Table Lamp

MLCMTL016PCMBK Matt Black

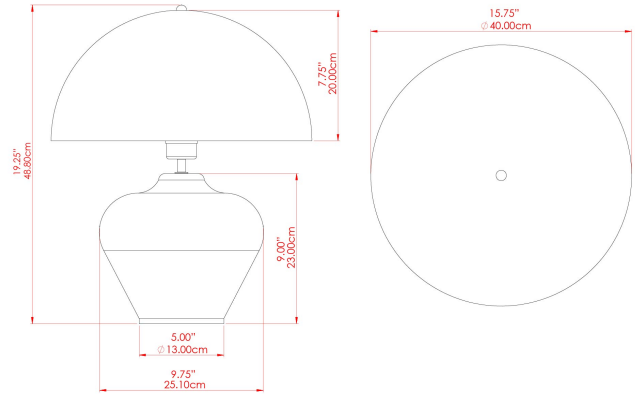

MATERIAL	Brass
HEIGHT	18.5"
WIDTH DIAMETER	15.75"
LENGTH PROJECTION	n/a
WEIGHT	4.8 kg 10.5 lbs
LAMPHOLDER	E26
MAX WATTAGE	40W
VOLTAGE	110/120v
ENVIRONMENTAL RATING	Dry Location (IP20)
CLASS PROTECTION	Class II
SHADE	-
FLEX BAR CHAIN LENGTH	n/a
CABLE TYPE	MLCA028 Black Fabric Braided Cable 2 Core Round

FIXING BRACKET: -



Product Notes:
1) Bulbs not included. 2) Dimensions do not include bulbs. 3) All products are individually made-to-order and therefore may differ slightly within manufacturing tolerances. 4) Cable / chain can be shortened during installation. Longer cable / chain lengths available on request. 5) Additional color finishes may be available on request. 6) Twisted cable is not available for UL wired products. Round cable in black or brown only is supplied instead. 7) Refer to our website for a full list of terms and conditions.



LAWSON Ceramic Table Lamp

MLCMTL016POLBRS Polished Brass

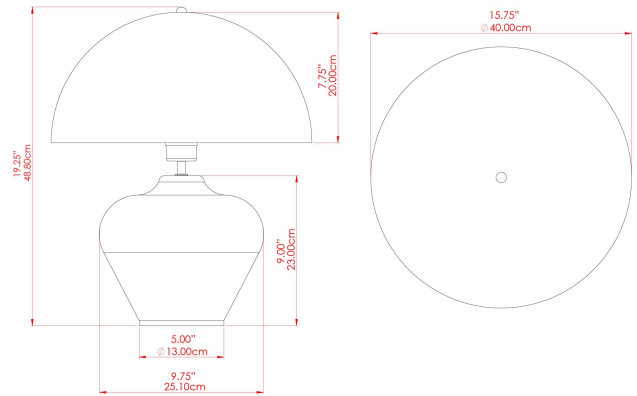

MATERIAL	Brass
HEIGHT	18.5"
WIDTH DIAMETER	15.75"
LENGTH PROJECTION	n/a
WEIGHT	4.8 kg 10.5 lbs
LAMPHOLDER	E26
MAX WATTAGE	40W
VOLTAGE	110/120v
ENVIRONMENTAL RATING	Dry Location (IP20)
CLASS PROTECTION	Class II
SHADE	-
FLEX BAR CHAIN LENGTH	n/a
CABLE TYPE	MLCA028 Black Fabric Braided Cable 2 Core Round

FIXING BRACKET: -



Product Notes:
 1) Bulbs not included. 2) Dimensions do not include bulbs. 3) All products are individually made-to-order and therefore may differ slightly within manufacturing tolerances. 4) Cable / chain can be shortened during installation. Longer cable / chain lengths available on request. 5) Additional color finishes may be available on request. 6) Twisted cable is not available for UL wired products. Round cable in black or brown only is supplied instead. 7) Refer to our website for a full list of terms and conditions.



LAWSON Ceramic Table Lamp

MLCMTL016SATBRS Satin Brass

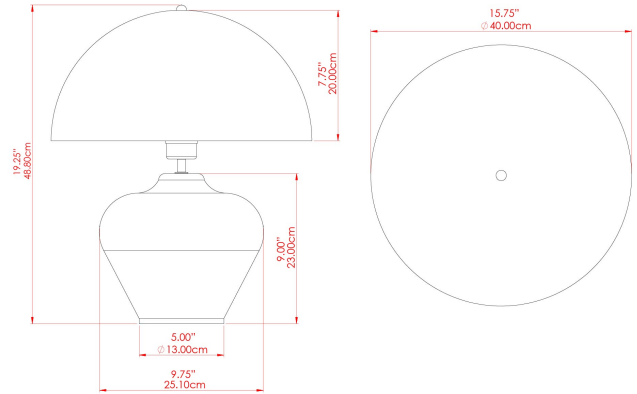

MATERIAL	Brass
HEIGHT	18.5"
WIDTH DIAMETER	15.75"
LENGTH PROJECTION	n/a
WEIGHT	4.8 kg 10.5 lbs
LAMPHOLDER	E26
MAX WATTAGE	40W
VOLTAGE	110/120v
ENVIRONMENTAL RATING	Dry Location (IP20)
CLASS PROTECTION	Class II
SHADE	-
FLEX BAR CHAIN LENGTH	n/a
CABLE TYPE	MLCA028 Black Fabric Braided Cable 2 Core Round

FIXING BRACKET: -



Product Notes:
 1) Bulbs not included. 2) Dimensions do not include bulbs. 3) All products are individually made-to-order and therefore may differ slightly within manufacturing tolerances. 4) Cable / chain can be shortened during installation. Longer cable / chain lengths available on request. 5) Additional color finishes may be available on request. 6) Twisted cable is not available for UL wired products. Round cable in black or brown only is supplied instead. 7) Refer to our website for a full list of terms and conditions.

