

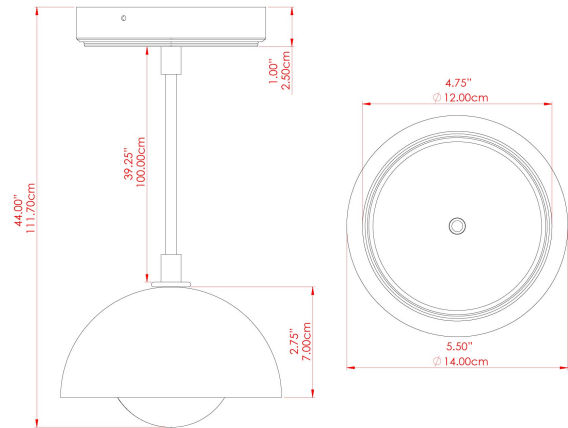

PANDO Ceramic Pendant

MLCMP076ANTBRS Antique Brass



MATERIAL	Brass Ceramic
HEIGHT	11.75"
WIDTH DIAMETER	5.5"
LENGTH PROJECTION	n/a
WEIGHT	1.1 kg 2.5 lbs
LAMPHOLDER	E26
MAX WATTAGE	40W
VOLTAGE	110/120v
ENVIRONMENTAL RATING	Dry Location (IP20)
CLASS PROTECTION	Class I
SHADE	MLCS075
FLEX BAR CHAIN LENGTH	40"
CABLE TYPE	MLCA047 Brown Fabric Braided Cable 2 Core Round

FIXING BRACKET: MLWB17

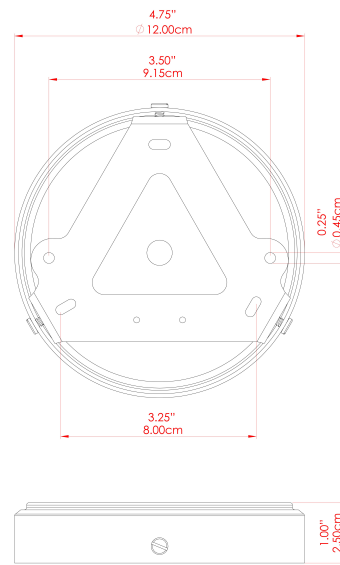

Product Notes:
1) Bulbs not included. 2) Dimensions do not include bulbs. 3) All products are individually made-to-order and therefore may differ slightly within manufacturing tolerances. 4) Cable / chain can be shortened during installation. Longer cable / chain lengths available on request. 5) Additional color finishes may be available on request. 6) Twisted cable is not available for UL wired products. Round cable in black or brown only is supplied instead. 7) Refer to our website for a full list of terms and conditions.





PANDO Ceramic Pendant

MLCMP076ANTSLV Antique Silver

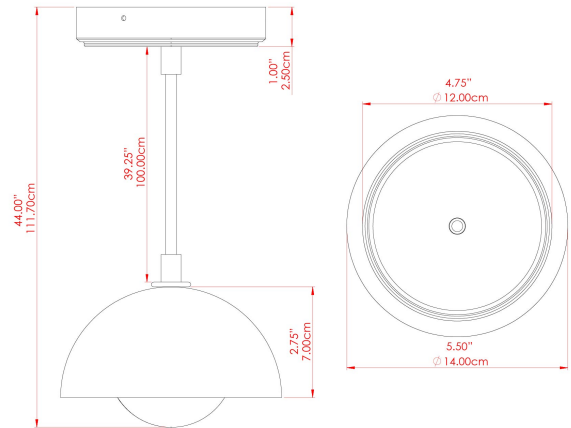

MATERIAL	Brass Ceramic
HEIGHT	11.75"
WIDTH DIAMETER	5.5"
LENGTH PROJECTION	n/a
WEIGHT	1.1 kg 2.5 lbs
LAMPHOLDER	E26
MAX WATTAGE	40W
VOLTAGE	110/120v
ENVIRONMENTAL RATING	Dry Location (IP20)
CLASS PROTECTION	Class I
SHADE	MLCS075
FLEX BAR CHAIN LENGTH	40"
CABLE TYPE	MLCA028 Black Fabric Braided Cable 2 Core Round

FIXING BRACKET: MLWB17

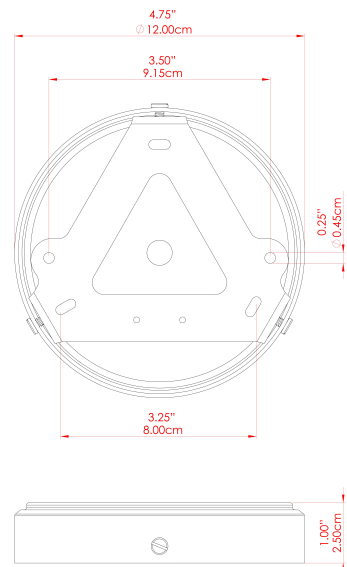

Product Notes:
1) Bulbs not included. 2) Dimensions do not include bulbs. 3) All products are individually made-to-order and therefore may differ slightly within manufacturing tolerances. 4) Cable / chain can be shortened during installation. Longer cable / chain lengths available on request. 5) Additional color finishes may be available on request. 6) Twisted cable is not available for UL wired products. Round cable in black or brown only is supplied instead. 7) Refer to our website for a full list of terms and conditions.





PANDO Ceramic Pendant

MLCMP076PCMBK Matt Black

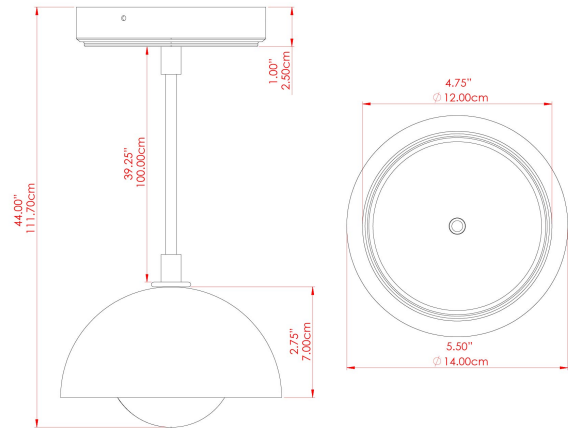

MATERIAL	Brass Ceramic
HEIGHT	11.75"
WIDTH DIAMETER	5.5"
LENGTH PROJECTION	n/a
WEIGHT	1.1 kg 2.5 lbs
LAMPHOLDER	E26
MAX WATTAGE	40W
VOLTAGE	110/120v
ENVIRONMENTAL RATING	Dry Location (IP20)
CLASS PROTECTION	Class I
SHADE	MLCS075
FLEX BAR CHAIN LENGTH	40"
CABLE TYPE	MLCA028 Black Fabric Braided Cable 2 Core Round

FIXING BRACKET: MLWB17



Product Notes:
 1) Bulbs not included. 2) Dimensions do not include bulbs. 3) All products are individually made-to-order and therefore may differ slightly within manufacturing tolerances. 4) Cable / chain can be shortened during installation. Longer cable / chain lengths available on request. 5) Additional color finishes may be available on request. 6) Twisted cable is not available for UL wired products. Round cable in black or brown only is supplied instead. 7) Refer to our website for a full list of terms and conditions.





PANDO Ceramic Pendant

MLCMP076POLBRS Polished Brass

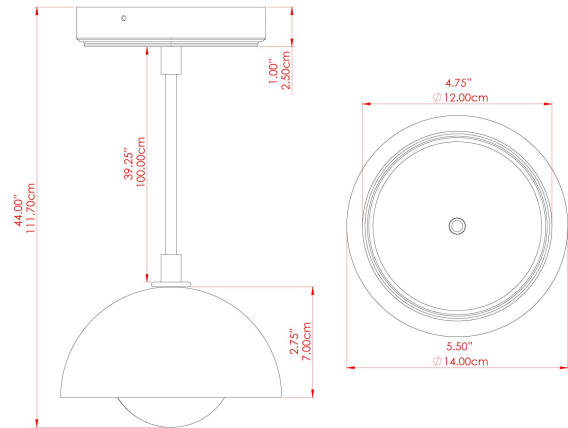

MATERIAL	Brass Ceramic
HEIGHT	11.75"
WIDTH DIAMETER	5.5"
LENGTH PROJECTION	n/a
WEIGHT	1.1 kg 2.5 lbs
LAMPHOLDER	E26
MAX WATTAGE	40W
VOLTAGE	110/120v
ENVIRONMENTAL RATING	Dry Location (IP20)
CLASS PROTECTION	Class I
SHADE	MLCS075
FLEX BAR CHAIN LENGTH	40"
CABLE TYPE	MLCA028 Black Fabric Braided Cable 2 Core Round

FIXING BRACKET: MLWB17



Product Notes:
 1) Bulbs not included. 2) Dimensions do not include bulbs. 3) All products are individually made-to-order and therefore may differ slightly within manufacturing tolerances. 4) Cable / chain can be shortened during installation. Longer cable / chain lengths available on request. 5) Additional color finishes may be available on request. 6) Twisted cable is not available for UL wired products. Round cable in black or brown only is supplied instead. 7) Refer to our website for a full list of terms and conditions.





PANDO Ceramic Pendant

MLCMP076SATBRS Satin Brass

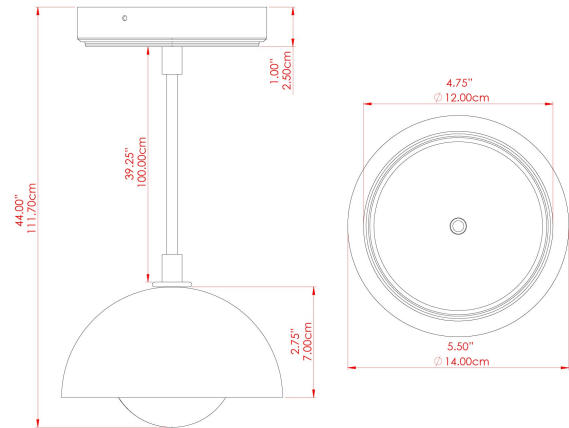

MATERIAL	Brass Ceramic
HEIGHT	11.75"
WIDTH DIAMETER	5.5"
LENGTH PROJECTION	n/a
WEIGHT	1.1 kg 2.5 lbs
LAMPHOLDER	E26
MAX WATTAGE	40W
VOLTAGE	110/120v
ENVIRONMENTAL RATING	Dry Location (IP20)
CLASS PROTECTION	Class I
SHADE	MLCS075
FLEX BAR CHAIN LENGTH	40"
CABLE TYPE	MLCA028 Black Fabric Braided Cable 2 Core Round

FIXING BRACKET: MLWB17



Product Notes:
 1) Bulbs not included. 2) Dimensions do not include bulbs. 3) All products are individually made-to-order and therefore may differ slightly within manufacturing tolerances. 4) Cable / chain can be shortened during installation. Longer cable / chain lengths available on request. 5) Additional color finishes may be available on request. 6) Twisted cable is not available for UL wired products. Round cable in black or brown only is supplied instead. 7) Refer to our website for a full list of terms and conditions.

