

NAKAI Ceramic Pendant

MLCMP070ANTBRSL Antique Brass

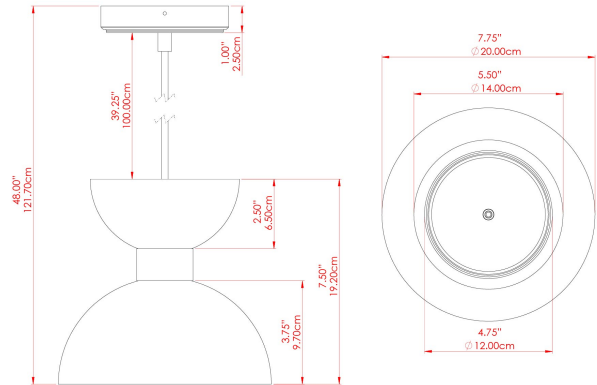

MATERIAL	Brass Ceramic
HEIGHT	7.75"
WIDTH DIAMETER	7.75"
LENGTH PROJECTION	n/a
WEIGHT	2 kg 4.5 lbs
LAMPHOLDER	G9
MAX WATTAGE	6.5W
VOLTAGE	110/120v
ENVIRONMENTAL RATING	Dry Location (IP20)
CLASS PROTECTION	Class I
SHADE	GL196 MLCS001 MLCS070
FLEX BAR CHAIN LENGTH	40"
CABLE TYPE	MLCA047 Brown Fabric Braided Cable 2 Core Round

FIXING BRACKET: MLWB17

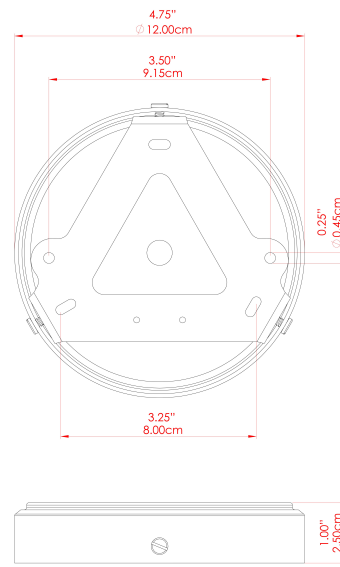

Product Notes:
 1) Bulbs not included. 2) Dimensions do not include bulbs. 3) All products are individually made-to-order and therefore may differ slightly within manufacturing tolerances. 4) Cable / chain can be shortened during installation. Longer cable / chain lengths available on request. 5) Additional color finishes may be available on request. 6) Twisted cable is not available for UL wired products. Round cable in black or brown only is supplied instead. 7) Refer to our website for a full list of terms and conditions.





NAKAI Ceramic Pendant

MLCMP070ANTBRSFR Antique Brass

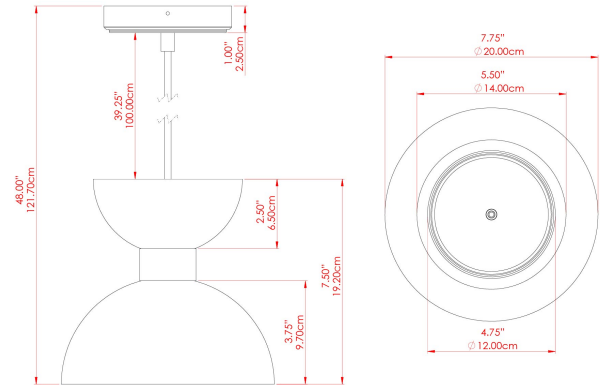

MATERIAL	Brass Ceramic
HEIGHT	7.75"
WIDTH DIAMETER	7.75"
LENGTH PROJECTION	n/a
WEIGHT	2 kg 4.5 lbs
LAMPHOLDER	G9
MAX WATTAGE	6.5W
VOLTAGE	110/120v
ENVIRONMENTAL RATING	Dry Location (IP20)
CLASS PROTECTION	Class I
SHADE	GL208 MLCS001 MLCS070
FLEX BAR CHAIN LENGTH	40"
CABLE TYPE	MLCA047 Brown Fabric Braided Cable 2 Core Round

FIXING BRACKET: MLWB17

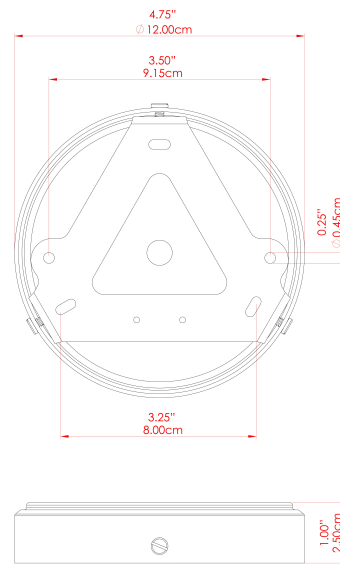

Product Notes:
 1) Bulbs not included. 2) Dimensions do not include bulbs. 3) All products are individually made-to-order and therefore may differ slightly within manufacturing tolerances. 4) Cable / chain can be shortened during installation. Longer cable / chain lengths available on request. 5) Additional color finishes may be available on request. 6) Twisted cable is not available for UL wired products. Round cable in black or brown only is supplied instead. 7) Refer to our website for a full list of terms and conditions.





NAKAI Ceramic Pendant

MLCMP070ANTBRSOP Antique Brass

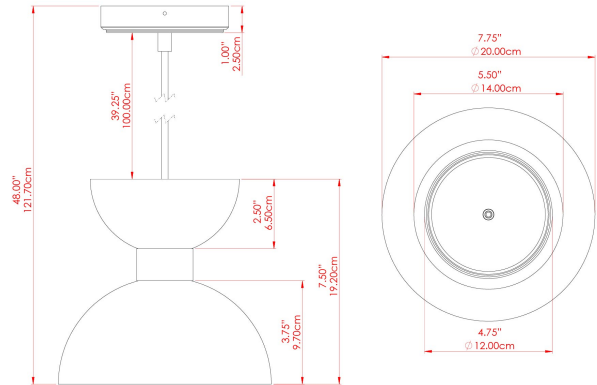

MATERIAL	Brass Ceramic
HEIGHT	7.75"
WIDTH DIAMETER	7.75"
LENGTH PROJECTION	n/a
WEIGHT	2 kg 4.5 lbs
LAMPHOLDER	G9
MAX WATTAGE	6.5W
VOLTAGE	110/120v
ENVIRONMENTAL RATING	Dry Location (IP20)
CLASS PROTECTION	Class I
SHADE	GL192 MLCS001 MLCS070
FLEX BAR CHAIN LENGTH	40"
CABLE TYPE	MLCA047 Brown Fabric Braided Cable 2 Core Round

FIXING BRACKET: MLWB17

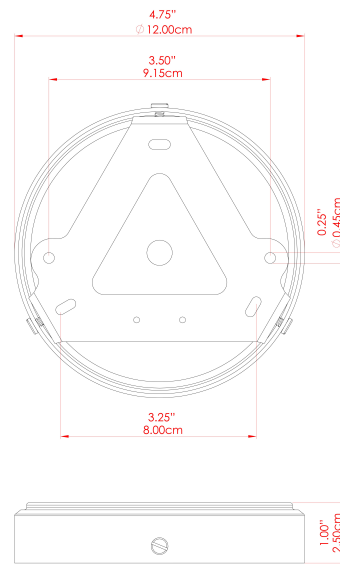

Product Notes:
 1) Bulbs not included. 2) Dimensions do not include bulbs. 3) All products are individually made-to-order and therefore may differ slightly within manufacturing tolerances. 4) Cable / chain can be shortened during installation. Longer cable / chain lengths available on request. 5) Additional color finishes may be available on request. 6) Twisted cable is not available for UL wired products. Round cable in black or brown only is supplied instead. 7) Refer to our website for a full list of terms and conditions.





NAKAI Ceramic Pendant

MLCMP070ANTSLVCL Antique Silver

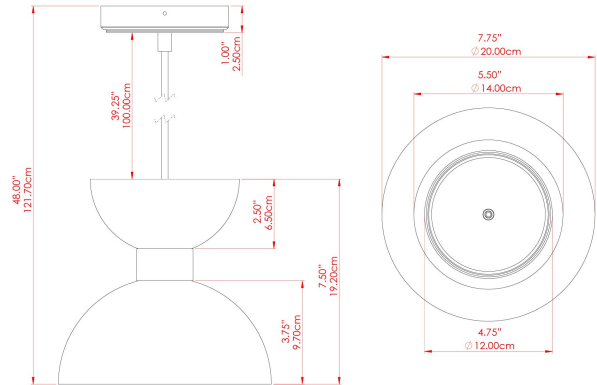

MATERIAL	Brass Ceramic
HEIGHT	7.75"
WIDTH DIAMETER	7.75"
LENGTH PROJECTION	n/a
WEIGHT	2 kg 4.5 lbs
LAMPHOLDER	G9
MAX WATTAGE	6.5W
VOLTAGE	110/120v
ENVIRONMENTAL RATING	Dry Location (IP20)
CLASS PROTECTION	Class I
SHADE	GL196 MLCS001 MLCS070
FLEX BAR CHAIN LENGTH	40"
CABLE TYPE	MLCA028 Black Fabric Braided Cable 2 Core Round

FIXING BRACKET: MLWB17

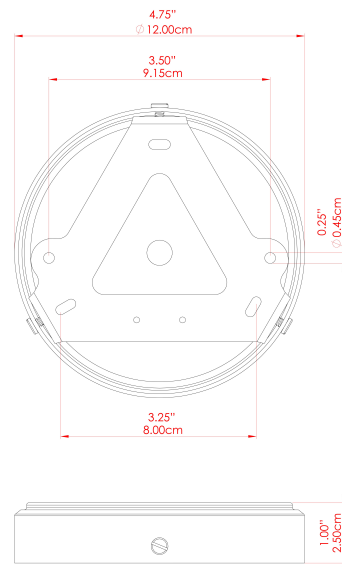

Product Notes:
1) Bulbs not included. 2) Dimensions do not include bulbs. 3) All products are individually made-to-order and therefore may differ slightly within manufacturing tolerances. 4) Cable / chain can be shortened during installation. Longer cable / chain lengths available on request. 5) Additional color finishes may be available on request. 6) Twisted cable is not available for UL wired products. Round cable in black or brown only is supplied instead. 7) Refer to our website for a full list of terms and conditions.





NAKAI Ceramic Pendant

MLCMP070ANTSLVFR Antique Silver

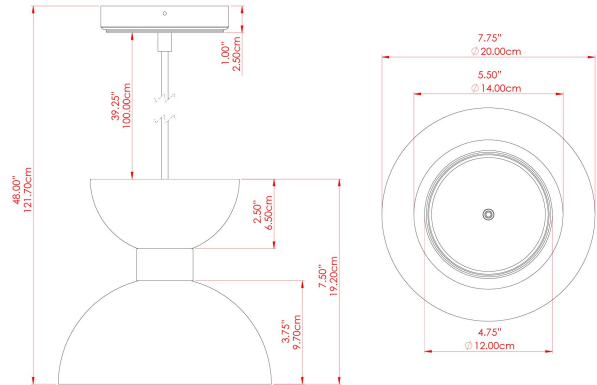

MATERIAL	Brass Ceramic
HEIGHT	7.75"
WIDTH DIAMETER	7.75"
LENGTH PROJECTION	n/a
WEIGHT	2 kg 4.5 lbs
LAMPHOLDER	G9
MAX WATTAGE	6.5W
VOLTAGE	110/120v
ENVIRONMENTAL RATING	Dry Location (IP20)
CLASS PROTECTION	Class I
SHADE	GL208 MLCS001 MLCS070
FLEX BAR CHAIN LENGTH	40"
CABLE TYPE	MLCA028 Black Fabric Braided Cable 2 Core Round

FIXING BRACKET: MLWB17

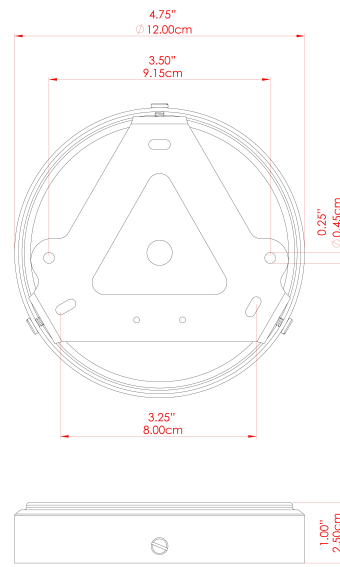

Product Notes:
 1) Bulbs not included. 2) Dimensions do not include bulbs. 3) All products are individually made-to-order and therefore may differ slightly within manufacturing tolerances. 4) Cable / chain can be shortened during installation. Longer cable / chain lengths available on request. 5) Additional color finishes may be available on request. 6) Twisted cable is not available for UL wired products. Round cable in black or brown only is supplied instead. 7) Refer to our website for a full list of terms and conditions.





NAKAI Ceramic Pendant

MLCMP070ANTSLVOP Antique Silver

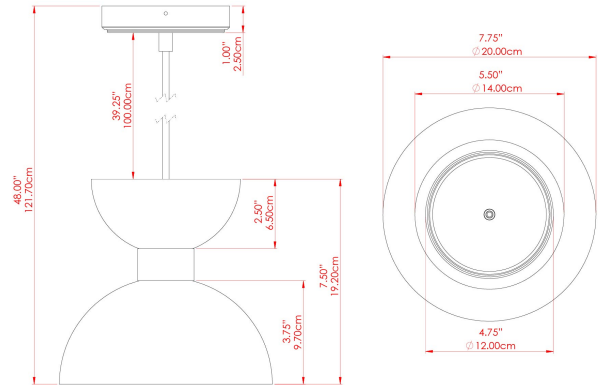

MATERIAL	Brass Ceramic
HEIGHT	7.75"
WIDTH DIAMETER	7.75"
LENGTH PROJECTION	n/a
WEIGHT	2 kg 4.5 lbs
LAMPHOLDER	G9
MAX WATTAGE	6.5W
VOLTAGE	110/120v
ENVIRONMENTAL RATING	Dry Location (IP20)
CLASS PROTECTION	Class I
SHADE	GL192 MLCS001 MLCS070
FLEX BAR CHAIN LENGTH	40"
CABLE TYPE	MLCA028 Black Fabric Braided Cable 2 Core Round

FIXING BRACKET: MLWB17

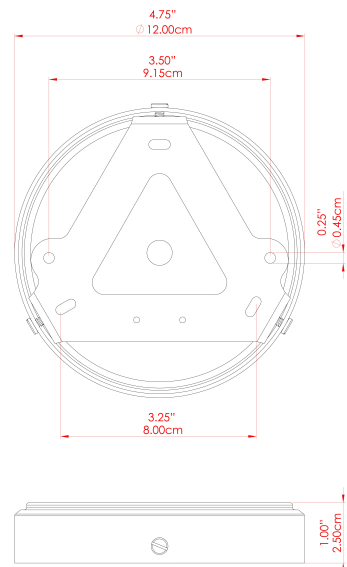

Product Notes:
 1) Bulbs not included. 2) Dimensions do not include bulbs. 3) All products are individually made-to-order and therefore may differ slightly within manufacturing tolerances. 4) Cable / chain can be shortened during installation. Longer cable / chain lengths available on request. 5) Additional color finishes may be available on request. 6) Twisted cable is not available for UL wired products. Round cable in black or brown only is supplied instead. 7) Refer to our website for a full list of terms and conditions.





NAKAI Ceramic Pendant

MLCMP070PCMBKCL Matt Black

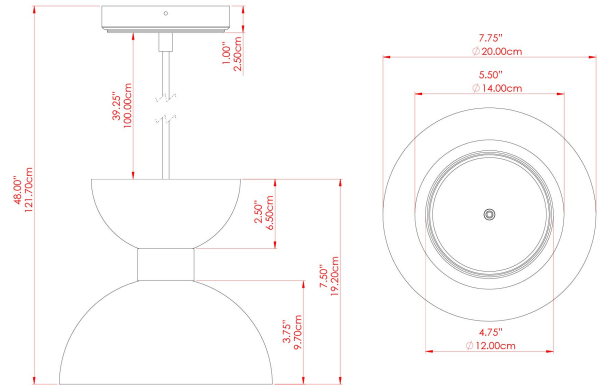

MATERIAL	Brass Ceramic
HEIGHT	7.75"
WIDTH DIAMETER	7.75"
LENGTH PROJECTION	n/a
WEIGHT	2 kg 4.5 lbs
LAMPHOLDER	G9
MAX WATTAGE	6.5W
VOLTAGE	110/120v
ENVIRONMENTAL RATING	Dry Location (IP20)
CLASS PROTECTION	Class I
SHADE	GL196 MLCS001 MLCS070
FLEX BAR CHAIN LENGTH	40"
CABLE TYPE	MLCA028 Black Fabric Braided Cable 2 Core Round

FIXING BRACKET: MLWB17

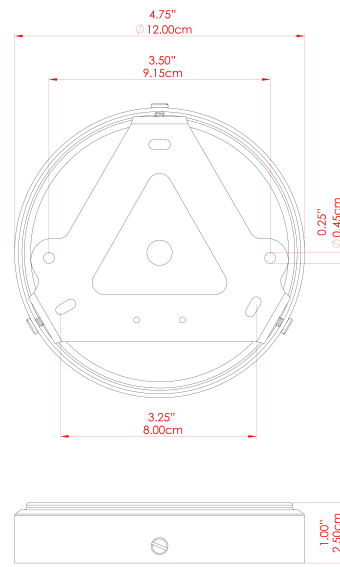

Product Notes:
 1) Bulbs not included. 2) Dimensions do not include bulbs. 3) All products are individually made-to-order and therefore may differ slightly within manufacturing tolerances. 4) Cable / chain can be shortened during installation. Longer cable / chain lengths available on request. 5) Additional color finishes may be available on request. 6) Twisted cable is not available for UL wired products. Round cable in black or brown only is supplied instead. 7) Refer to our website for a full list of terms and conditions.





NAKAI Ceramic Pendant

MLCMP070PCMBKFR Matt Black

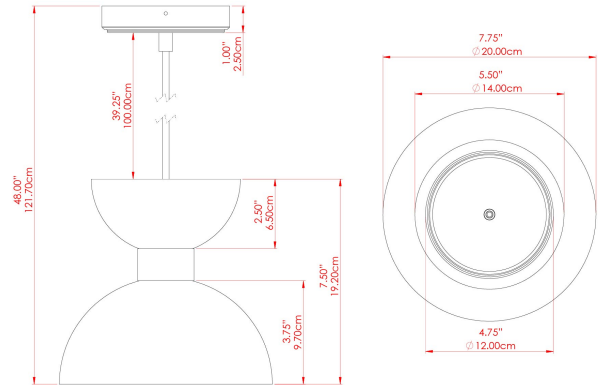

MATERIAL	Brass Ceramic
HEIGHT	7.75"
WIDTH DIAMETER	7.75"
LENGTH PROJECTION	n/a
WEIGHT	2 kg 4.5 lbs
LAMPHOLDER	G9
MAX WATTAGE	6.5W
VOLTAGE	110/120v
ENVIRONMENTAL RATING	Dry Location (IP20)
CLASS PROTECTION	Class I
SHADE	GL208 MLCS001 MLCS070
FLEX BAR CHAIN LENGTH	40"
CABLE TYPE	MLCA028 Black Fabric Braided Cable 2 Core Round

FIXING BRACKET: MLWB17

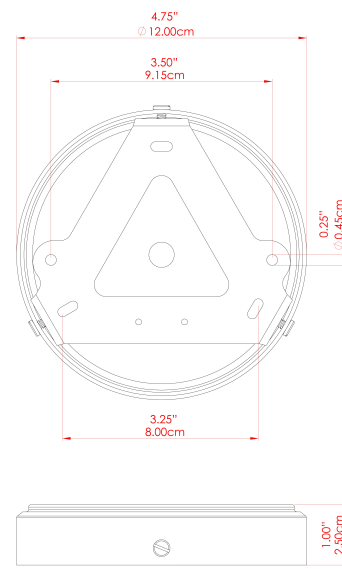

Product Notes:

1) Bulbs not included. 2) Dimensions do not include bulbs. 3) All products are individually made-to-order and therefore may differ slightly within manufacturing tolerances. 4) Cable / chain can be shortened during installation. Longer cable / chain lengths available on request. 5) Additional color finishes may be available on request. 6) Twisted cable is not available for UL wired products. Round cable in black or brown only is supplied instead. 7) Refer to our website for a full list of terms and conditions.





NAKAI Ceramic Pendant

MLCMP070PCMBKOP Matt Black

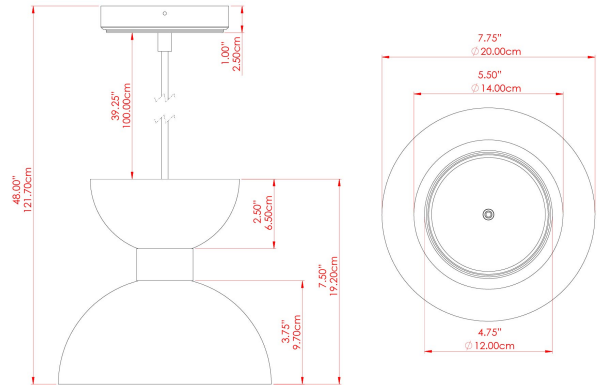

MATERIAL	Brass Ceramic
HEIGHT	7.75"
WIDTH DIAMETER	7.75"
LENGTH PROJECTION	n/a
WEIGHT	2 kg 4.5 lbs
LAMPHOLDER	G9
MAX WATTAGE	6.5W
VOLTAGE	110/120v
ENVIRONMENTAL RATING	Dry Location (IP20)
CLASS PROTECTION	Class I
SHADE	GL192 MLCS001 MLCS070
FLEX BAR CHAIN LENGTH	40"
CABLE TYPE	MLCA028 Black Fabric Braided Cable 2 Core Round

FIXING BRACKET: MLWB17

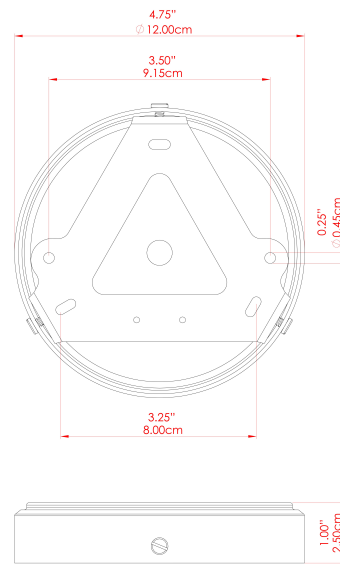

Product Notes:
 1) Bulbs not included. 2) Dimensions do not include bulbs. 3) All products are individually made-to-order and therefore may differ slightly within manufacturing tolerances. 4) Cable / chain can be shortened during installation. Longer cable / chain lengths available on request. 5) Additional color finishes may be available on request. 6) Twisted cable is not available for UL wired products. Round cable in black or brown only is supplied instead. 7) Refer to our website for a full list of terms and conditions.





NAKAI Ceramic Pendant

MLCMP070POLBRSC Polished Brass

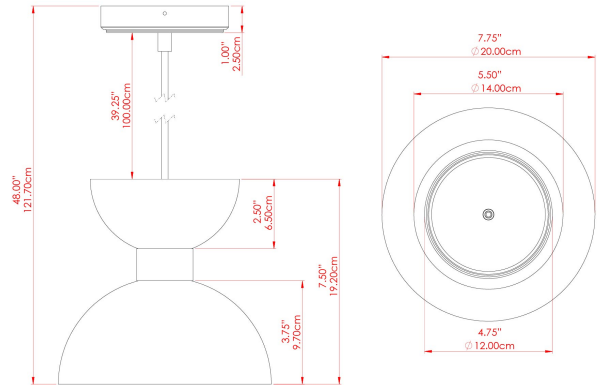

MATERIAL	Brass Ceramic
HEIGHT	7.75"
WIDTH DIAMETER	7.75"
LENGTH PROJECTION	n/a
WEIGHT	2 kg 4.5 lbs
LAMPHOLDER	G9
MAX WATTAGE	6.5W
VOLTAGE	110/120v
ENVIRONMENTAL RATING	Dry Location (IP20)
CLASS PROTECTION	Class I
SHADE	GL196 MLCS001 MLCS070
FLEX BAR CHAIN LENGTH	40"
CABLE TYPE	MLCA028 Black Fabric Braided Cable 2 Core Round

FIXING BRACKET: MLWB17

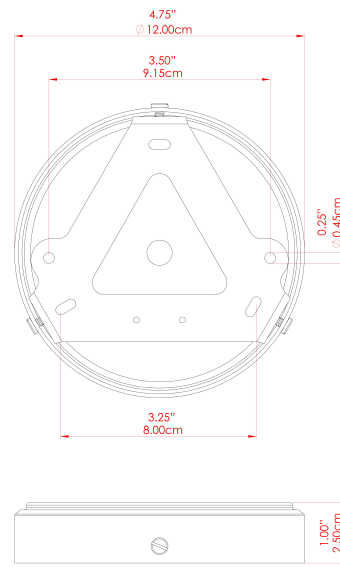

Product Notes:
 1) Bulbs not included. 2) Dimensions do not include bulbs. 3) All products are individually made-to-order and therefore may differ slightly within manufacturing tolerances. 4) Cable / chain can be shortened during installation. Longer cable / chain lengths available on request. 5) Additional color finishes may be available on request. 6) Twisted cable is not available for UL wired products. Round cable in black or brown only is supplied instead. 7) Refer to our website for a full list of terms and conditions.





NAKAI Ceramic Pendant

MLCMP070POLBRSFR Polished Brass

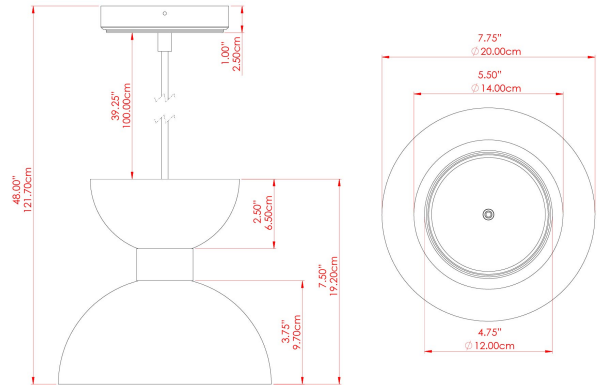

MATERIAL	Brass Ceramic
HEIGHT	7.75"
WIDTH DIAMETER	7.75"
LENGTH PROJECTION	n/a
WEIGHT	2 kg 4.5 lbs
LAMPHOLDER	G9
MAX WATTAGE	6.5W
VOLTAGE	110/120v
ENVIRONMENTAL RATING	Dry Location (IP20)
CLASS PROTECTION	Class I
SHADE	GL208 MLCS001 MLCS070
FLEX BAR CHAIN LENGTH	40"
CABLE TYPE	MLCA028 Black Fabric Braided Cable 2 Core Round

FIXING BRACKET: MLWB17

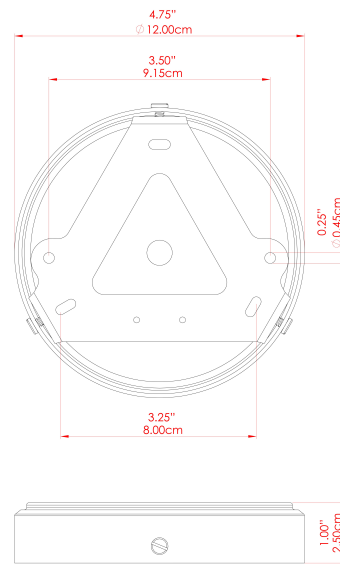

Product Notes:
 1) Bulbs not included. 2) Dimensions do not include bulbs. 3) All products are individually made-to-order and therefore may differ slightly within manufacturing tolerances. 4) Cable / chain can be shortened during installation. Longer cable / chain lengths available on request. 5) Additional color finishes may be available on request. 6) Twisted cable is not available for UL wired products. Round cable in black or brown only is supplied instead. 7) Refer to our website for a full list of terms and conditions.





NAKAI Ceramic Pendant

MLCMP070POLBRSOP Polished Brass

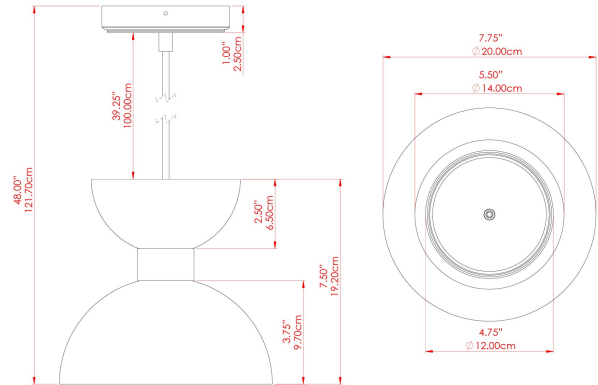

MATERIAL	Brass Ceramic
HEIGHT	7.75"
WIDTH DIAMETER	7.75"
LENGTH PROJECTION	n/a
WEIGHT	2 kg 4.5 lbs
LAMPHOLDER	G9
MAX WATTAGE	6.5W
VOLTAGE	110/120v
ENVIRONMENTAL RATING	Dry Location (IP20)
CLASS PROTECTION	Class I
SHADE	GL192 MLCS001 MLCS070
FLEX BAR CHAIN LENGTH	40"
CABLE TYPE	MLCA028 Black Fabric Braided Cable 2 Core Round

FIXING BRACKET: MLWB17

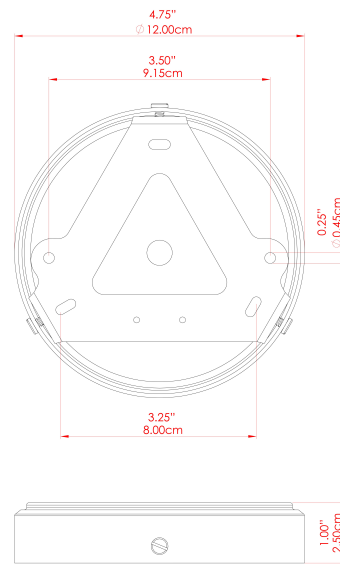

Product Notes:
 1) Bulbs not included. 2) Dimensions do not include bulbs. 3) All products are individually made-to-order and therefore may differ slightly within manufacturing tolerances. 4) Cable / chain can be shortened during installation. Longer cable / chain lengths available on request. 5) Additional color finishes may be available on request. 6) Twisted cable is not available for UL wired products. Round cable in black or brown only is supplied instead. 7) Refer to our website for a full list of terms and conditions.





NAKAI Ceramic Pendant

MLCMP070SATBRSL Satin Brass

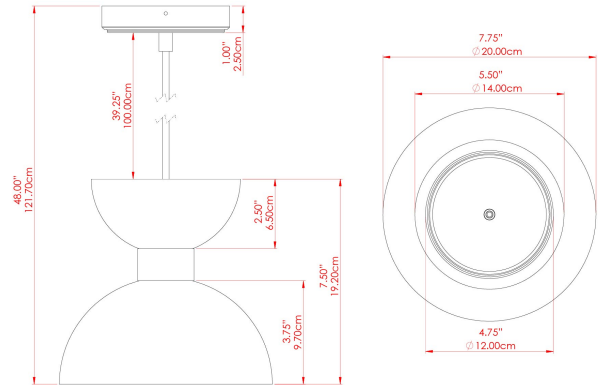

MATERIAL	Brass Ceramic
HEIGHT	7.75"
WIDTH DIAMETER	7.75"
LENGTH PROJECTION	n/a
WEIGHT	2 kg 4.5 lbs
LAMPHOLDER	G9
MAX WATTAGE	6.5W
VOLTAGE	110/120v
ENVIRONMENTAL RATING	Dry Location (IP20)
CLASS PROTECTION	Class I
SHADE	GL196 MLCS001 MLCS070
FLEX BAR CHAIN LENGTH	40"
CABLE TYPE	MLCA028 Black Fabric Braided Cable 2 Core Round

FIXING BRACKET: MLWB17

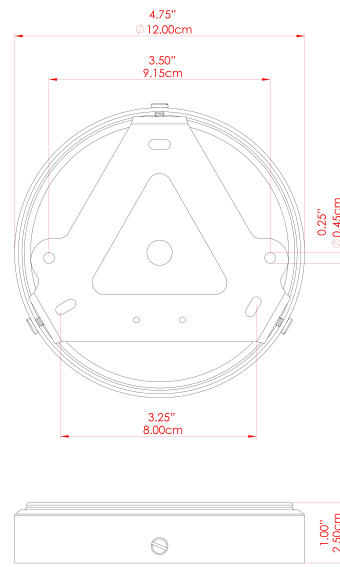

Product Notes:
 1) Bulbs not included. 2) Dimensions do not include bulbs. 3) All products are individually made-to-order and therefore may differ slightly within manufacturing tolerances. 4) Cable / chain can be shortened during installation. Longer cable / chain lengths available on request. 5) Additional color finishes may be available on request. 6) Twisted cable is not available for UL wired products. Round cable in black or brown only is supplied instead. 7) Refer to our website for a full list of terms and conditions.



NAKAI Ceramic Pendant

MLCMP070SATBRSFR Satin Brass

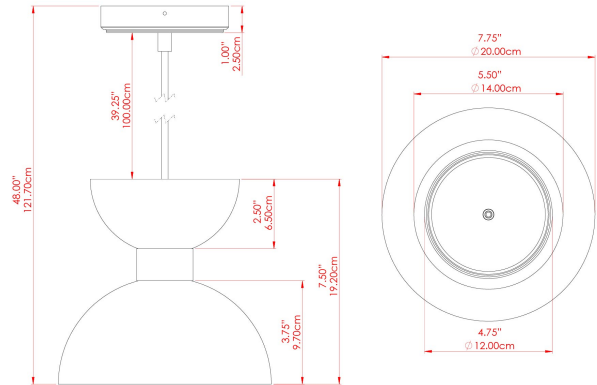

MATERIAL	Brass Ceramic
HEIGHT	7.75"
WIDTH DIAMETER	7.75"
LENGTH PROJECTION	n/a
WEIGHT	2 kg 4.5 lbs
LAMPHOLDER	G9
MAX WATTAGE	6.5W
VOLTAGE	110/120v
ENVIRONMENTAL RATING	Dry Location (IP20)
CLASS PROTECTION	Class I
SHADE	GL208 MLCS001 MLCS070
FLEX BAR CHAIN LENGTH	40"
CABLE TYPE	MLCA028 Black Fabric Braided Cable 2 Core Round

FIXING BRACKET: MLWB17

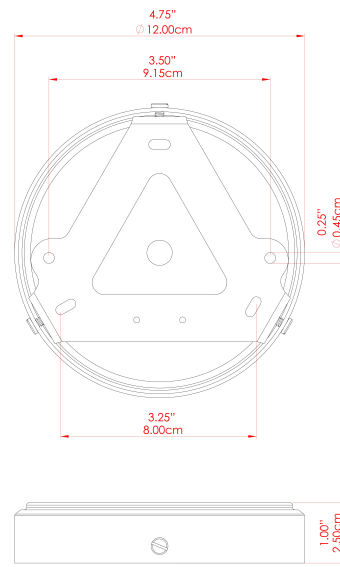

Product Notes:
 1) Bulbs not included. 2) Dimensions do not include bulbs. 3) All products are individually made-to-order and therefore may differ slightly within manufacturing tolerances. 4) Cable / chain can be shortened during installation. Longer cable / chain lengths available on request. 5) Additional color finishes may be available on request. 6) Twisted cable is not available for UL wired products. Round cable in black or brown only is supplied instead. 7) Refer to our website for a full list of terms and conditions.





NAKAI Ceramic Pendant

MLCMP070SATBRSOP Satin Brass

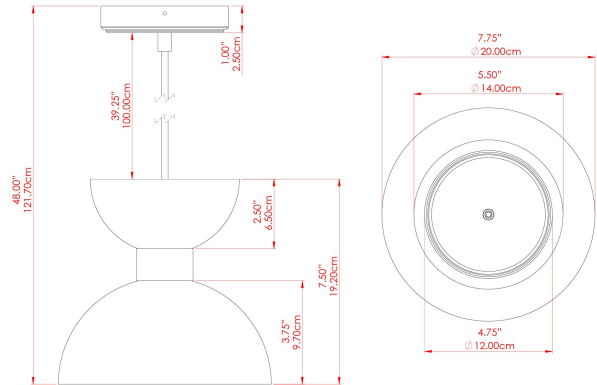

MATERIAL	Brass Ceramic
HEIGHT	7.75"
WIDTH DIAMETER	7.75"
LENGTH PROJECTION	n/a
WEIGHT	2 kg 4.5 lbs
LAMPHOLDER	G9
MAX WATTAGE	6.5W
VOLTAGE	110/120v
ENVIRONMENTAL RATING	Dry Location (IP20)
CLASS PROTECTION	Class I
SHADE	GL192 MLCS001 MLCS070
FLEX BAR CHAIN LENGTH	40"
CABLE TYPE	MLCA028 Black Fabric Braided Cable 2 Core Round

FIXING BRACKET: MLWB17

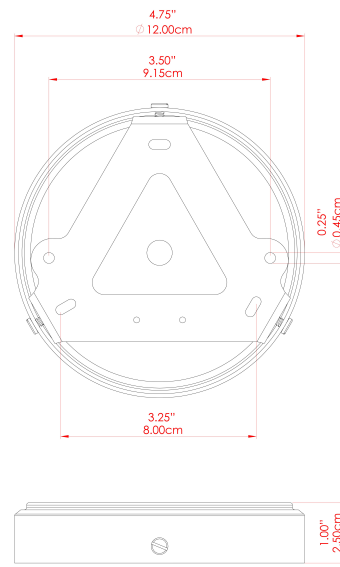

Product Notes:
 1) Bulbs not included. 2) Dimensions do not include bulbs. 3) All products are individually made-to-order and therefore may differ slightly within manufacturing tolerances. 4) Cable / chain can be shortened during installation. Longer cable / chain lengths available on request. 5) Additional color finishes may be available on request. 6) Twisted cable is not available for UL wired products. Round cable in black or brown only is supplied instead. 7) Refer to our website for a full list of terms and conditions.

