

# NAKAI Ceramic Pendant

# MLCMP068ANTBRSFR Antique Brass

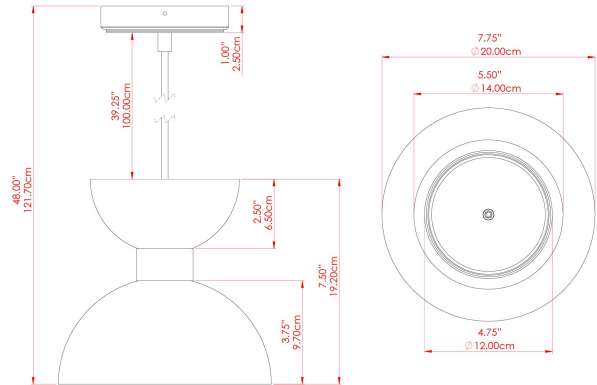

MATERIAL	Brass   Ceramic
HEIGHT	7.75"
WIDTH   DIAMETER	7.75"
LENGTH   PROJECTION	n/a
WEIGHT	2 kg   4.5 lbs
LAMPHOLDER	G9
MAX WATTAGE	6.5W
VOLTAGE	110/120v
ENVIRONMENTAL RATING	Dry Location (IP20)
CLASS PROTECTION	Class I
SHADE	GL208   MLCS035   MLCS043
FLEX   BAR   CHAIN LENGTH	40"
CABLE TYPE	MLCA047   Brown Fabric Braided Cable   2 Core Round

### FIXING BRACKET: MLWB17



Product Notes:  
 1) Bulbs not included. 2) Dimensions do not include bulbs. 3) All products are individually made-to-order and therefore may differ slightly within manufacturing tolerances. 4) Cable / chain can be shortened during installation. Longer cable / chain lengths available on request. 5) Additional color finishes may be available on request. 6) Twisted cable is not available for UL wired products. Round cable in black or brown only is supplied instead. 7) Refer to our website for a full list of terms and conditions.



# NAKAI Ceramic Pendant

# MLCMP068ANTBRSOP Antique Brass

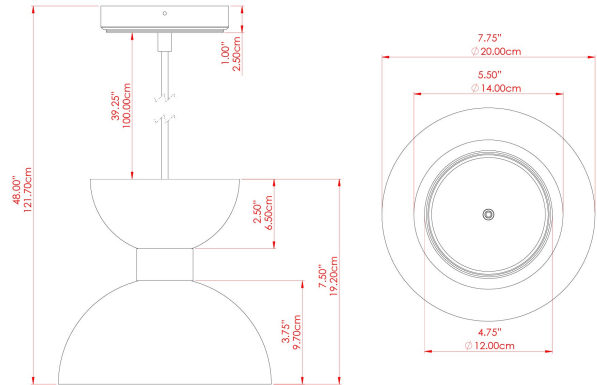

MATERIAL	Brass   Ceramic
HEIGHT	7.75"
WIDTH   DIAMETER	7.75"
LENGTH   PROJECTION	n/a
WEIGHT	2 kg   4.5 lbs
LAMPHOLDER	G9
MAX WATTAGE	6.5W
VOLTAGE	110/120v
ENVIRONMENTAL RATING	Dry Location (IP20)
CLASS PROTECTION	Class I
SHADE	GL192   MLCS035   MLCS043
FLEX   BAR   CHAIN LENGTH	40"
CABLE TYPE	MLCA047   Brown Fabric Braided Cable   2 Core Round

### FIXING BRACKET: MLWB17



Product Notes:  
 1) Bulbs not included. 2) Dimensions do not include bulbs. 3) All products are individually made-to-order and therefore may differ slightly within manufacturing tolerances. 4) Cable / chain can be shortened during installation. Longer cable / chain lengths available on request. 5) Additional color finishes may be available on request. 6) Twisted cable is not available for UL wired products. Round cable in black or brown only is supplied instead. 7) Refer to our website for a full list of terms and conditions.





# NAKAI Ceramic Pendant

# MLCMP068ANTBRACL Antique Brass

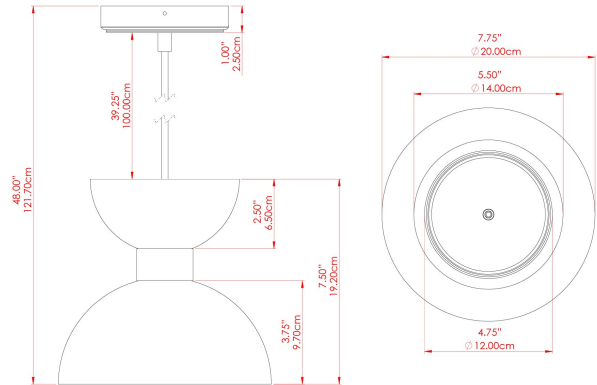

MATERIAL	Brass   Ceramic
HEIGHT	7.75"
WIDTH   DIAMETER	7.75"
LENGTH   PROJECTION	n/a
WEIGHT	2 kg   4.5 lbs
LAMPHOLDER	G9
MAX WATTAGE	6.5W
VOLTAGE	110/120v
ENVIRONMENTAL RATING	Dry Location (IP20)
CLASS PROTECTION	Class I
SHADE	GL196   MLCS035   MLCS043
FLEX   BAR   CHAIN LENGTH	40"
CABLE TYPE	MLCA047   Brown Fabric Braided Cable   2 Core Round

### FIXING BRACKET: MLWB17

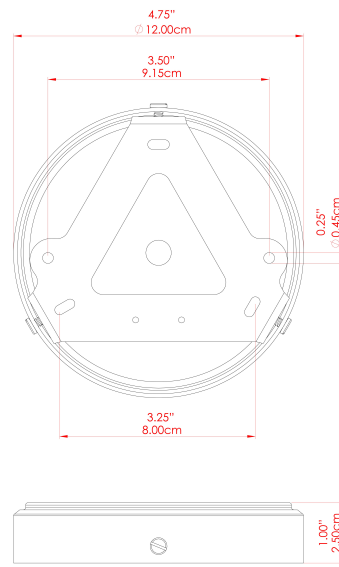

Product Notes:  
 1) Bulbs not included. 2) Dimensions do not include bulbs. 3) All products are individually made-to-order and therefore may differ slightly within manufacturing tolerances. 4) Cable / chain can be shortened during installation. Longer cable / chain lengths available on request. 5) Additional color finishes may be available on request. 6) Twisted cable is not available for UL wired products. Round cable in black or brown only is supplied instead. 7) Refer to our website for a full list of terms and conditions.





# NAKAI Ceramic Pendant

MLCMP068ANTSLVCL Antique Silver

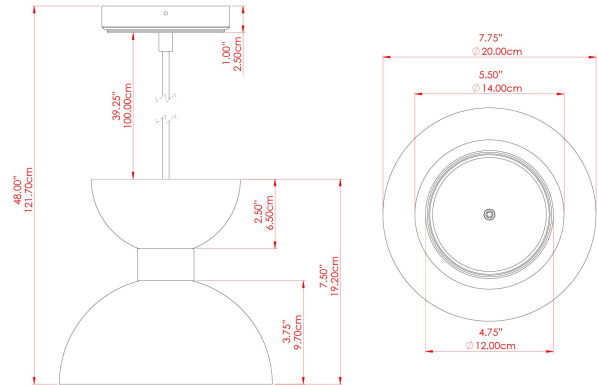

MATERIAL	Brass   Ceramic
HEIGHT	7.75"
WIDTH   DIAMETER	7.75"
LENGTH   PROJECTION	n/a
WEIGHT	2 kg   4.5 lbs
LAMPHOLDER	G9
MAX WATTAGE	6.5W
VOLTAGE	110/120v
ENVIRONMENTAL RATING	Dry Location (IP20)
CLASS PROTECTION	Class I
SHADE	GL196   MLCS035   MLCS043
FLEX   BAR   CHAIN LENGTH	40"
CABLE TYPE	MLCA028   Black Fabric Braided Cable   2 Core Round

FIXING BRACKET: MLWB17



Product Notes:  
 1) Bulbs not included. 2) Dimensions do not include bulbs. 3) All products are individually made-to-order and therefore may differ slightly within manufacturing tolerances. 4) Cable / chain can be shortened during installation. Longer cable / chain lengths available on request. 5) Additional color finishes may be available on request. 6) Twisted cable is not available for UL wired products. Round cable in black or brown only is supplied instead. 7) Refer to our website for a full list of terms and conditions.





## NAKAI Ceramic Pendant

MLCMP068ANTSLVFR Antique Silver

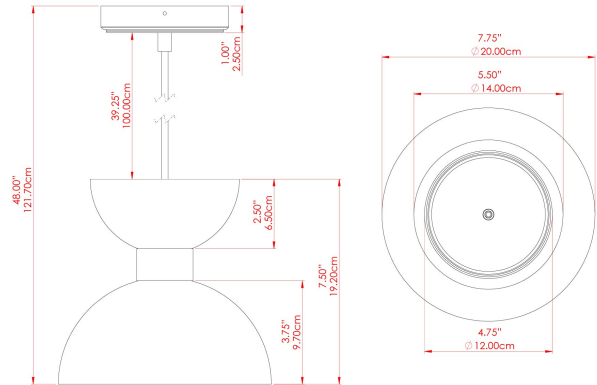

MATERIAL	Brass   Ceramic
HEIGHT	7.75"
WIDTH   DIAMETER	7.75"
LENGTH   PROJECTION	n/a
WEIGHT	2 kg   4.5 lbs
LAMPHOLDER	G9
MAX WATTAGE	6.5W
VOLTAGE	110/120v
ENVIRONMENTAL RATING	Dry Location (IP20)
CLASS PROTECTION	Class I
SHADE	GL208   MLCS035   MLCS043
FLEX   BAR   CHAIN LENGTH	40"
CABLE TYPE	MLCA028   Black Fabric Braided Cable   2 Core Round

FIXING BRACKET: MLWB17

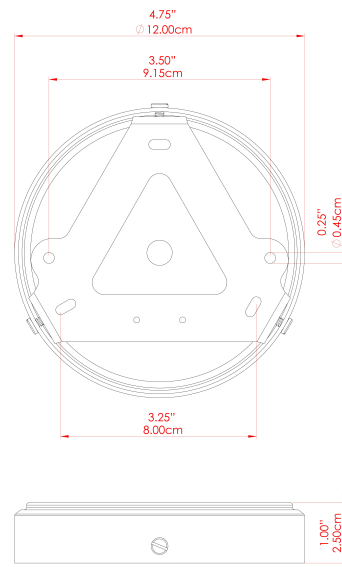

WWW.MULLANLIGHTING.COM

**Product Notes:**

1) Bulbs not included. 2) Dimensions do not include bulbs. 3) All products are individually made-to-order and therefore may differ slightly within manufacturing tolerances. 4) Cable / chain can be shortened during installation. Longer cable / chain lengths available on request. 5) Additional color finishes may be available on request. 6) Twisted cable is not available for UL wired products. Round cable in black or brown only is supplied instead. 7) Refer to our website for a full list of terms and conditions.



# NAKAI Ceramic Pendant

# MLCMP068ANTSLVOP Antique Silver

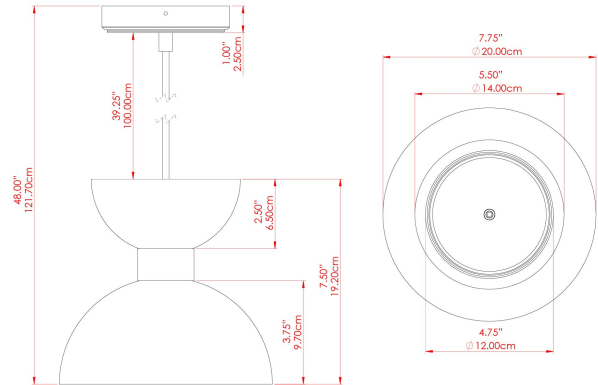

MATERIAL	Brass   Ceramic
HEIGHT	7.75"
WIDTH   DIAMETER	7.75"
LENGTH   PROJECTION	n/a
WEIGHT	2 kg   4.5 lbs
LAMPHOLDER	G9
MAX WATTAGE	6.5W
VOLTAGE	110/120v
ENVIRONMENTAL RATING	Dry Location (IP20)
CLASS PROTECTION	Class I
SHADE	GL192   MLCS035   MLCS043
FLEX   BAR   CHAIN LENGTH	40"
CABLE TYPE	MLCA028   Black Fabric Braided Cable   2 Core Round

### FIXING BRACKET: MLWB17

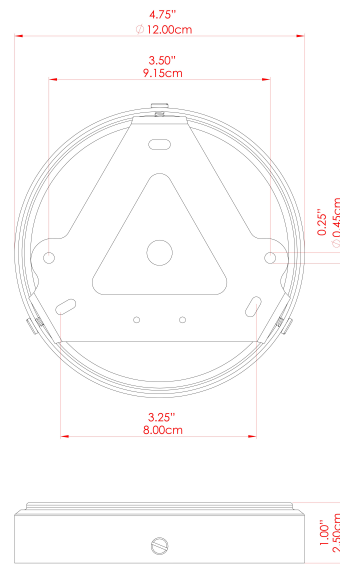

Product Notes:  
 1) Bulbs not included. 2) Dimensions do not include bulbs. 3) All products are individually made-to-order and therefore may differ slightly within manufacturing tolerances. 4) Cable / chain can be shortened during installation. Longer cable / chain lengths available on request. 5) Additional color finishes may be available on request. 6) Twisted cable is not available for UL wired products. Round cable in black or brown only is supplied instead. 7) Refer to our website for a full list of terms and conditions.





## NAKAI Ceramic Pendant

MLCMP068PCMBKCL Matt Black

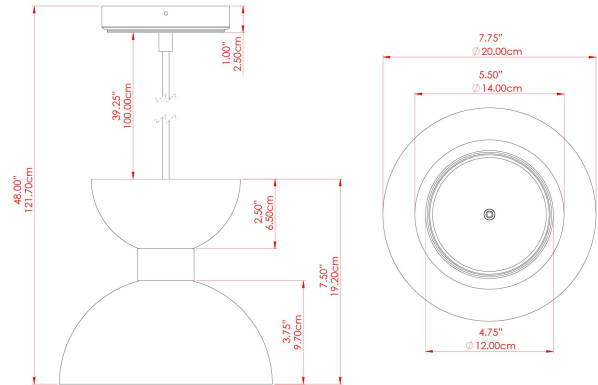

MATERIAL	Brass   Ceramic
HEIGHT	7.75"
WIDTH   DIAMETER	7.75"
LENGTH   PROJECTION	n/a
WEIGHT	2 kg   4.5 lbs
LAMPHOLDER	G9
MAX WATTAGE	6.5W
VOLTAGE	110/120v
ENVIRONMENTAL RATING	Dry Location (IP20)
CLASS PROTECTION	Class I
SHADE	GL196   MLCS035   MLCS043
FLEX   BAR   CHAIN LENGTH	40"
CABLE TYPE	MLCA028   Black Fabric Braided Cable   2 Core Round

### FIXING BRACKET: MLWB17

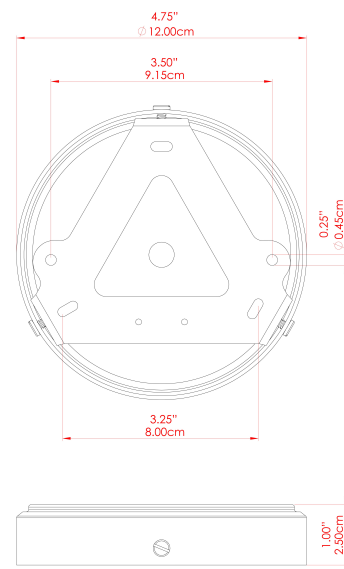

Product Notes:  
1) Bulbs not included. 2) Dimensions do not include bulbs. 3) All products are individually made-to-order and therefore may differ slightly within manufacturing tolerances. 4) Cable / chain can be shortened during installation. Longer cable / chain lengths available on request. 5) Additional color finishes may be available on request. 6) Twisted cable is not available for UL wired products. Round cable in black or brown only is supplied instead. 7) Refer to our website for a full list of terms and conditions.





## NAKAI Ceramic Pendant

MLCMP068PCMBKFR Matt Black

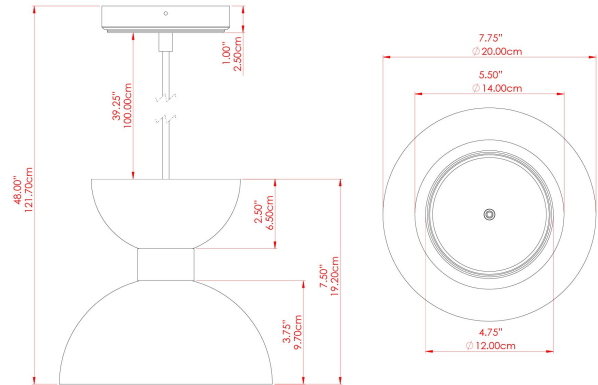

MATERIAL	Brass   Ceramic
HEIGHT	7.75"
WIDTH   DIAMETER	7.75"
LENGTH   PROJECTION	n/a
WEIGHT	2 kg   4.5 lbs
LAMPHOLDER	G9
MAX WATTAGE	6.5W
VOLTAGE	110/120v
ENVIRONMENTAL RATING	Dry Location (IP20)
CLASS PROTECTION	Class I
SHADE	GL208   MLCS035   MLCS043
FLEX   BAR   CHAIN LENGTH	40"
CABLE TYPE	MLCA028   Black Fabric Braided Cable   2 Core Round

### FIXING BRACKET: MLWB17

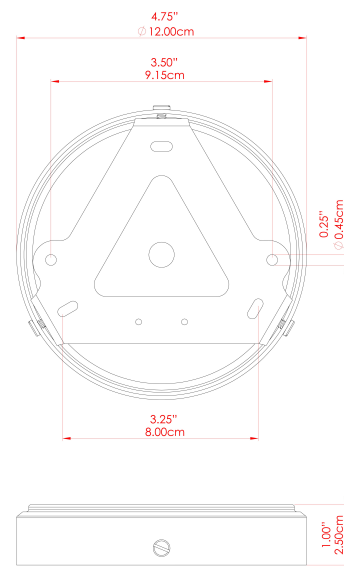

WWW.MULLANLIGHTING.COM

#### Product Notes:

1) Bulbs not included. 2) Dimensions do not include bulbs. 3) All products are individually made-to-order and therefore may differ slightly within manufacturing tolerances. 4) Cable / chain can be shortened during installation. Longer cable / chain lengths available on request. 5) Additional color finishes may be available on request. 6) Twisted cable is not available for UL wired products. Round cable in black or brown only is supplied instead. 7) Refer to our website for a full list of terms and conditions.



# NAKAI Ceramic Pendant

MLCMP068PCMBKOP Matt Black

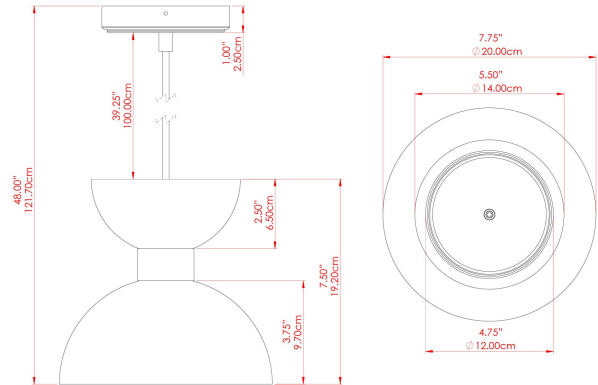

MATERIAL	Brass   Ceramic
HEIGHT	7.75"
WIDTH   DIAMETER	7.75"
LENGTH   PROJECTION	n/a
WEIGHT	2 kg   4.5 lbs
LAMPHOLDER	G9
MAX WATTAGE	6.5W
VOLTAGE	110/120v
ENVIRONMENTAL RATING	Dry Location (IP20)
CLASS PROTECTION	Class I
SHADE	GL192   MLCS035   MLCS043
FLEX   BAR   CHAIN LENGTH	40"
CABLE TYPE	MLCA028   Black Fabric Braided Cable   2 Core Round

### FIXING BRACKET: MLWB17

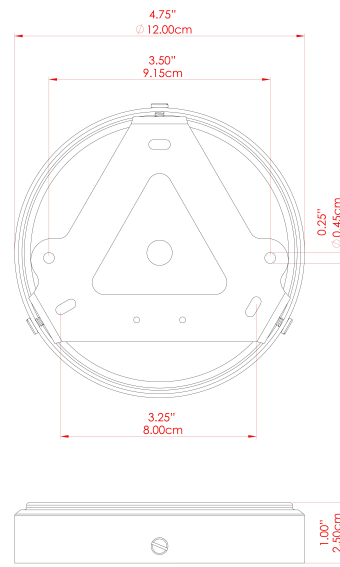

Product Notes:  
 1) Bulbs not included. 2) Dimensions do not include bulbs. 3) All products are individually made-to-order and therefore may differ slightly within manufacturing tolerances. 4) Cable / chain can be shortened during installation. Longer cable / chain lengths available on request. 5) Additional color finishes may be available on request. 6) Twisted cable is not available for UL wired products. Round cable in black or brown only is supplied instead. 7) Refer to our website for a full list of terms and conditions.



# NAKAI Ceramic Pendant

## MLCMP068POLBRSC Polished Brass

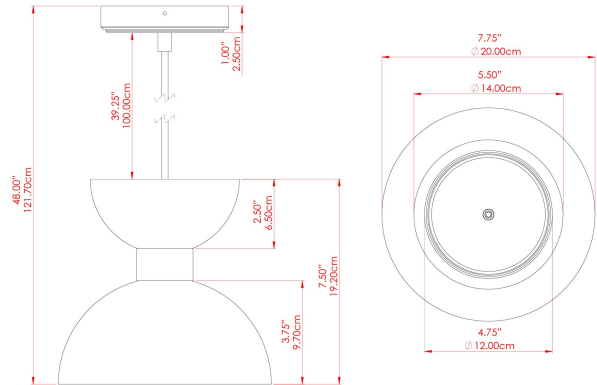

MATERIAL	Brass   Ceramic
HEIGHT	7.75"
WIDTH   DIAMETER	7.75"
LENGTH   PROJECTION	n/a
WEIGHT	2 kg   4.5 lbs
LAMPHOLDER	G9
MAX WATTAGE	6.5W
VOLTAGE	110/120v
ENVIRONMENTAL RATING	Dry Location (IP20)
CLASS PROTECTION	Class I
SHADE	GL196   MLCS035   MLCS043
FLEX   BAR   CHAIN LENGTH	40"
CABLE TYPE	MLCA028   Black Fabric Braided Cable   2 Core Round

### FIXING BRACKET: MLWB17

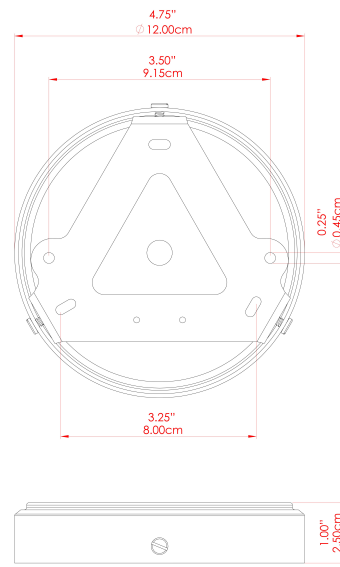

Product Notes:  
 1) Bulbs not included. 2) Dimensions do not include bulbs. 3) All products are individually made-to-order and therefore may differ slightly within manufacturing tolerances. 4) Cable / chain can be shortened during installation. Longer cable / chain lengths available on request. 5) Additional color finishes may be available on request. 6) Twisted cable is not available for UL wired products. Round cable in black or brown only is supplied instead. 7) Refer to our website for a full list of terms and conditions.





# NAKAI Ceramic Pendant

MLCMP068POLBRSFR Polished Brass

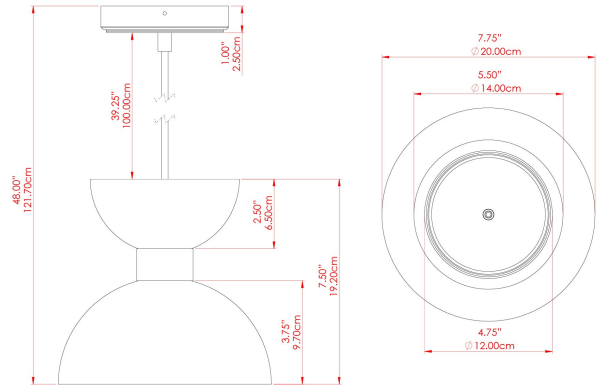

MATERIAL	Brass   Ceramic
HEIGHT	7.75"
WIDTH   DIAMETER	7.75"
LENGTH   PROJECTION	n/a
WEIGHT	2 kg   4.5 lbs
LAMPHOLDER	G9
MAX WATTAGE	6.5W
VOLTAGE	110/120v
ENVIRONMENTAL RATING	Dry Location (IP20)
CLASS PROTECTION	Class I
SHADE	GL208   MLCS035   MLCS043
FLEX   BAR   CHAIN LENGTH	40"
CABLE TYPE	MLCA028   Black Fabric Braided Cable   2 Core Round

### FIXING BRACKET: MLWB17

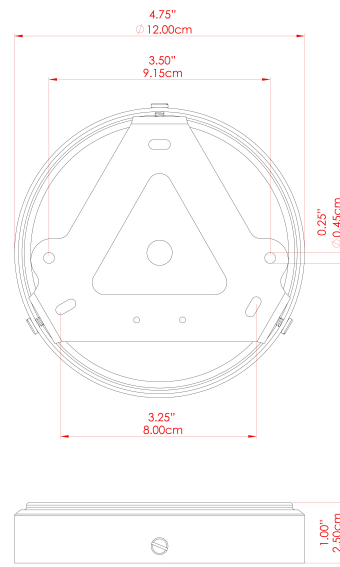

Product Notes:  
 1) Bulbs not included. 2) Dimensions do not include bulbs. 3) All products are individually made-to-order and therefore may differ slightly within manufacturing tolerances. 4) Cable / chain can be shortened during installation. Longer cable / chain lengths available on request. 5) Additional color finishes may be available on request. 6) Twisted cable is not available for UL wired products. Round cable in black or brown only is supplied instead. 7) Refer to our website for a full list of terms and conditions.





# NAKAI Ceramic Pendant

MLCMP068POLBRSOP Polished Brass

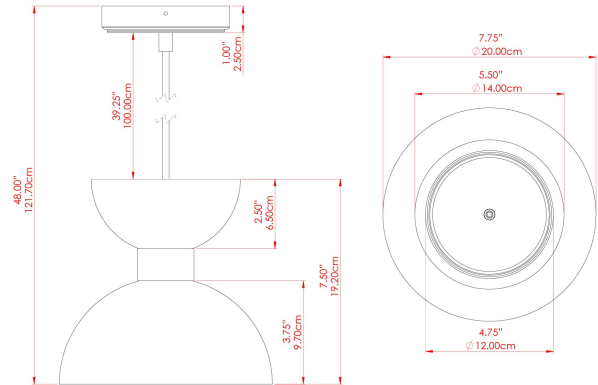

MATERIAL	Brass   Ceramic
HEIGHT	7.75"
WIDTH   DIAMETER	7.75"
LENGTH   PROJECTION	n/a
WEIGHT	2 kg   4.5 lbs
LAMPHOLDER	G9
MAX WATTAGE	6.5W
VOLTAGE	110/120v
ENVIRONMENTAL RATING	Dry Location (IP20)
CLASS PROTECTION	Class I
SHADE	GL192   MLCS035   MLCS043
FLEX   BAR   CHAIN LENGTH	40"
CABLE TYPE	MLCA028   Black Fabric Braided Cable   2 Core Round

### FIXING BRACKET: MLWB17

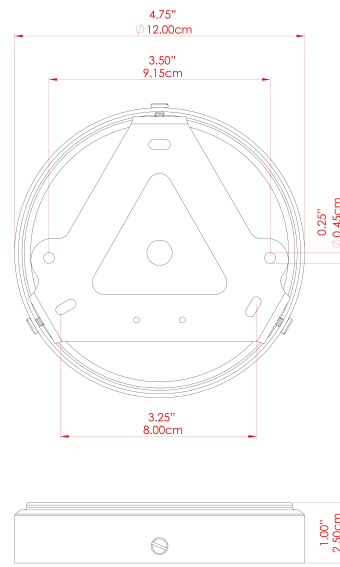

Product Notes:  
 1) Bulbs not included. 2) Dimensions do not include bulbs. 3) All products are individually made-to-order and therefore may differ slightly within manufacturing tolerances. 4) Cable / chain can be shortened during installation. Longer cable / chain lengths available on request. 5) Additional color finishes may be available on request. 6) Twisted cable is not available for UL wired products. Round cable in black or brown only is supplied instead. 7) Refer to our website for a full list of terms and conditions.



# NAKAI Ceramic Pendant

MLCMP068SATBRSL Satin Brass

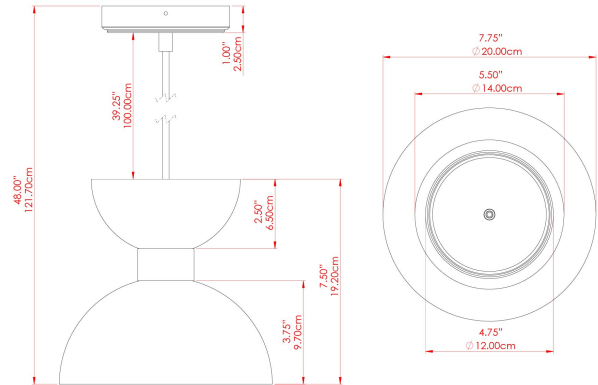

MATERIAL	Brass   Ceramic
HEIGHT	7.75"
WIDTH   DIAMETER	7.75"
LENGTH   PROJECTION	n/a
WEIGHT	2 kg   4.5 lbs
LAMPHOLDER	G9
MAX WATTAGE	6.5W
VOLTAGE	110/120v
ENVIRONMENTAL RATING	Dry Location (IP20)
CLASS PROTECTION	Class I
SHADE	GL196   MLCS035   MLCS043
FLEX   BAR   CHAIN LENGTH	40"
CABLE TYPE	MLCA028   Black Fabric Braided Cable   2 Core Round

### FIXING BRACKET: MLWB17

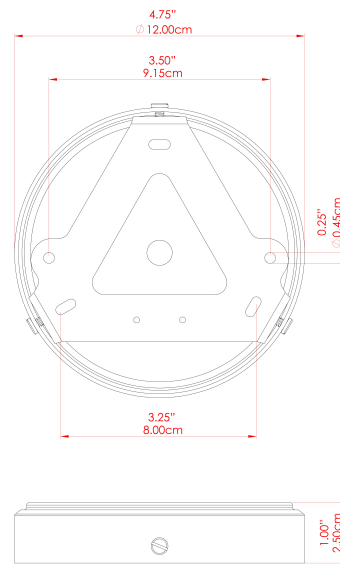

Product Notes:  
 1) Bulbs not included. 2) Dimensions do not include bulbs. 3) All products are individually made-to-order and therefore may differ slightly within manufacturing tolerances. 4) Cable / chain can be shortened during installation. Longer cable / chain lengths available on request. 5) Additional color finishes may be available on request. 6) Twisted cable is not available for UL wired products. Round cable in black or brown only is supplied instead. 7) Refer to our website for a full list of terms and conditions.



# NAKAI Ceramic Pendant

MLCMP068SATBRSFR Satin Brass

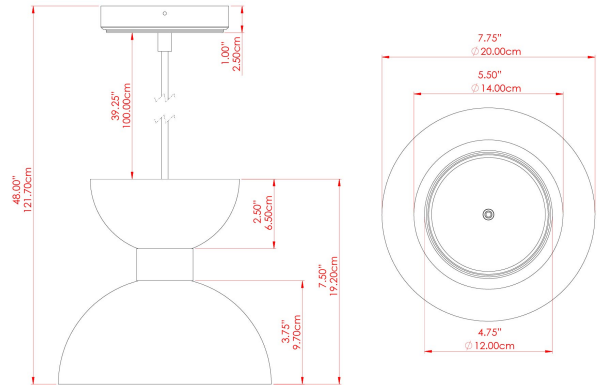

MATERIAL	Brass   Ceramic
HEIGHT	7.75"
WIDTH   DIAMETER	7.75"
LENGTH   PROJECTION	n/a
WEIGHT	2 kg   4.5 lbs
LAMPHOLDER	G9
MAX WATTAGE	6.5W
VOLTAGE	110/120v
ENVIRONMENTAL RATING	Dry Location (IP20)
CLASS PROTECTION	Class I
SHADE	GL208   MLCS035   MLCS043
FLEX   BAR   CHAIN LENGTH	40"
CABLE TYPE	MLCA028   Black Fabric Braided Cable   2 Core Round

### FIXING BRACKET: MLWB17

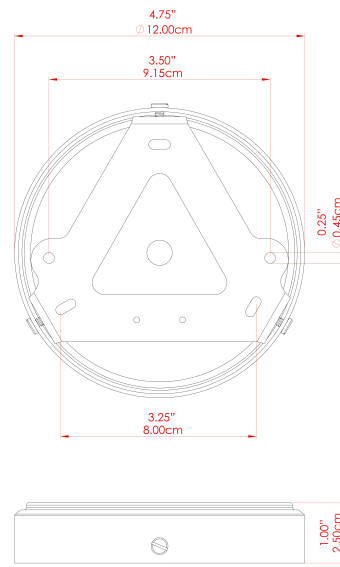

Product Notes:  
 1) Bulbs not included. 2) Dimensions do not include bulbs. 3) All products are individually made-to-order and therefore may differ slightly within manufacturing tolerances. 4) Cable / chain can be shortened during installation. Longer cable / chain lengths available on request. 5) Additional color finishes may be available on request. 6) Twisted cable is not available for UL wired products. Round cable in black or brown only is supplied instead. 7) Refer to our website for a full list of terms and conditions.



# NAKAI Ceramic Pendant

## MLCMP068SATBRSOP Satin Brass

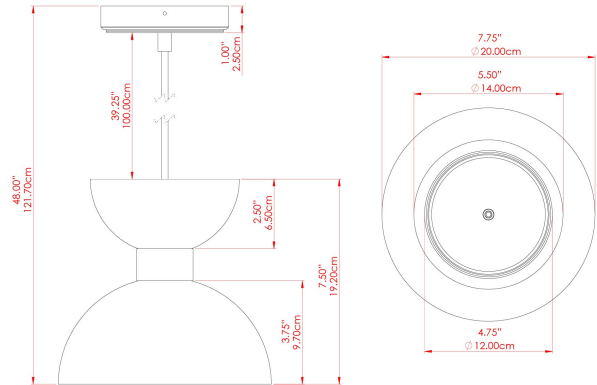

MATERIAL	Brass   Ceramic
HEIGHT	7.75"
WIDTH   DIAMETER	7.75"
LENGTH   PROJECTION	n/a
WEIGHT	2 kg   4.5 lbs
LAMPHOLDER	G9
MAX WATTAGE	6.5W
VOLTAGE	110/120v
ENVIRONMENTAL RATING	Dry Location (IP20)
CLASS PROTECTION	Class I
SHADE	GL192   MLCS035   MLCS043
FLEX   BAR   CHAIN LENGTH	40"
CABLE TYPE	MLCA028   Black Fabric Braided Cable   2 Core Round

### FIXING BRACKET: MLWB17

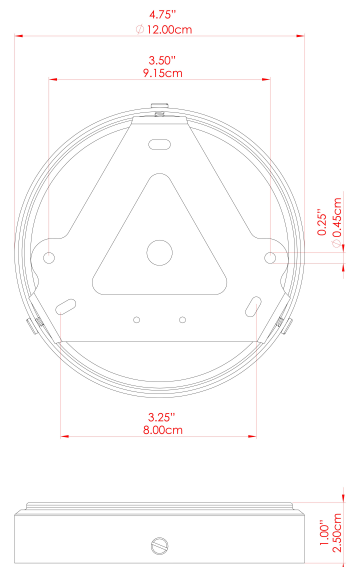

Product Notes:  
 1) Bulbs not included. 2) Dimensions do not include bulbs. 3) All products are individually made-to-order and therefore may differ slightly within manufacturing tolerances. 4) Cable / chain can be shortened during installation. Longer cable / chain lengths available on request. 5) Additional color finishes may be available on request. 6) Twisted cable is not available for UL wired products. Round cable in black or brown only is supplied instead. 7) Refer to our website for a full list of terms and conditions.

