

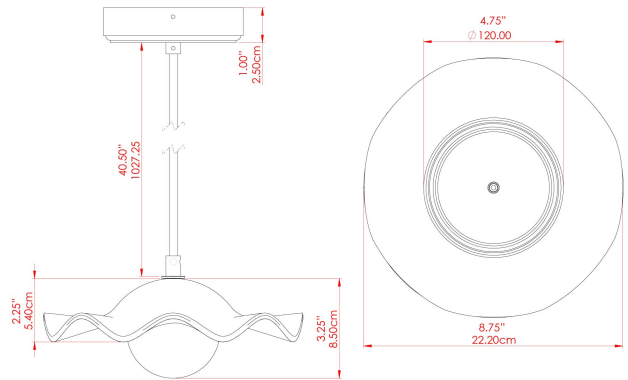

## RIVALE Ceramic Pendant

MLCMP058ANTBRSCl Antique Brass



MATERIAL	Ceramic   Brass   Glass
HEIGHT	3.25"
WIDTH   DIAMETER	8.25"
LENGTH   PROJECTION	n/a
WEIGHT	0.6 kg   1.3 lbs
LAMPHOLDER	G9
MAX WATTAGE	6.5W
VOLTAGE	110/120v
ENVIRONMENTAL RATING	Dry Location (IP20)
CLASS PROTECTION	Class I
SHADE	GL196   MLCS061
FLEX   BAR   CHAIN LENGTH	40"
CABLE TYPE	MLCA047   Brown Fabric Braided Cable   2 Core Round

FIXING BRACKET: MLWB17

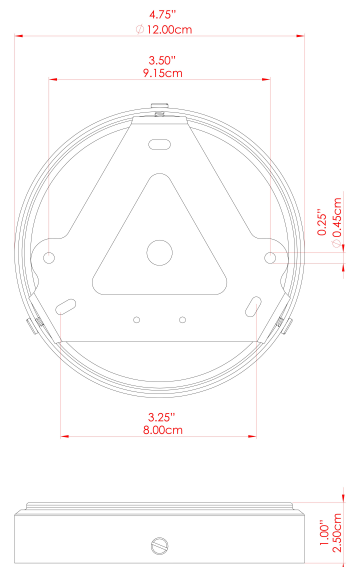

Product Notes:  
1) Bulbs not included. 2) Dimensions do not include bulbs. 3) All products are individually made-to-order and therefore may differ slightly within manufacturing tolerances. 4) Cable / chain can be shortened during installation. Longer cable / chain lengths available on request. 5) Additional color finishes may be available on request. 6) Twisted cable is not available for UL wired products. Round cable in black or brown only is supplied instead. 7) Refer to our website for a full list of terms and conditions.





## RIVALE Ceramic Pendant

MLCMP058ANTBRSFR Antique Brass

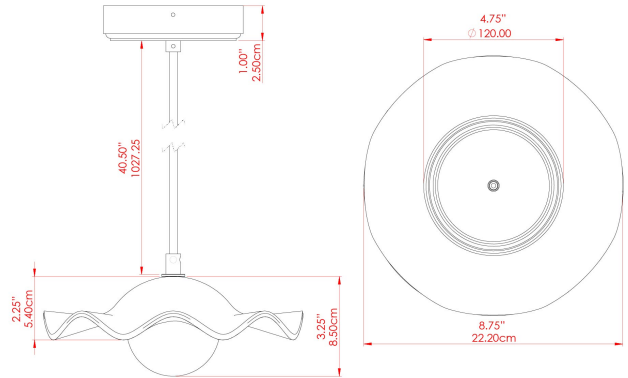

MATERIAL	Ceramic   Brass   Glass
HEIGHT	3.25"
WIDTH   DIAMETER	8.25"
LENGTH   PROJECTION	n/a
WEIGHT	0.6 kg   1.3 lbs
LAMPHOLDER	G9
MAX WATTAGE	6.5W
VOLTAGE	110/120v
ENVIRONMENTAL RATING	Dry Location (IP20)
CLASS PROTECTION	Class I
SHADE	GL208   MLCS061
FLEX   BAR   CHAIN LENGTH	40"
CABLE TYPE	MLCA047   Brown Fabric Braided Cable   2 Core Round

FIXING BRACKET: MLWB17

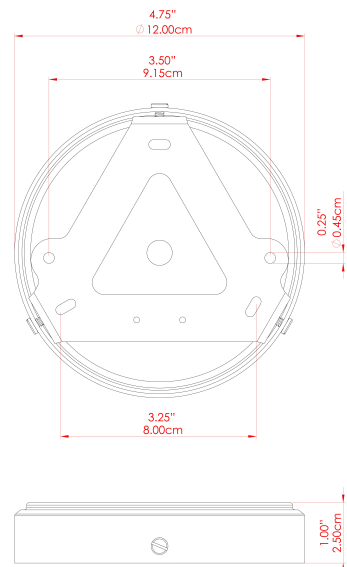

Product Notes:  
1) Bulbs not included. 2) Dimensions do not include bulbs. 3) All products are individually made-to-order and therefore may differ slightly within manufacturing tolerances. 4) Cable / chain can be shortened during installation. Longer cable / chain lengths available on request. 5) Additional color finishes may be available on request. 6) Twisted cable is not available for UL wired products. Round cable in black or brown only is supplied instead. 7) Refer to our website for a full list of terms and conditions.



# RIVALE Ceramic Pendant

# MLCMP058ANTBRSOP Antique Brass

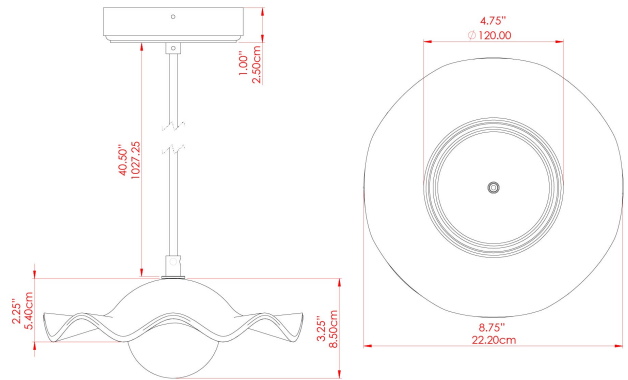

MATERIAL	Ceramic   Brass   Glass
HEIGHT	3.25"
WIDTH   DIAMETER	8.25"
LENGTH   PROJECTION	n/a
WEIGHT	0.6 kg   1.3 lbs
LAMPHOLDER	G9
MAX WATTAGE	6.5W
VOLTAGE	110/120v
ENVIRONMENTAL RATING	Dry Location (IP20)
CLASS PROTECTION	Class I
SHADE	GL192   MLCS061
FLEX   BAR   CHAIN LENGTH	40"
CABLE TYPE	MLCA047   Brown Fabric Braided Cable   2 Core Round

### FIXING BRACKET: MLWB17

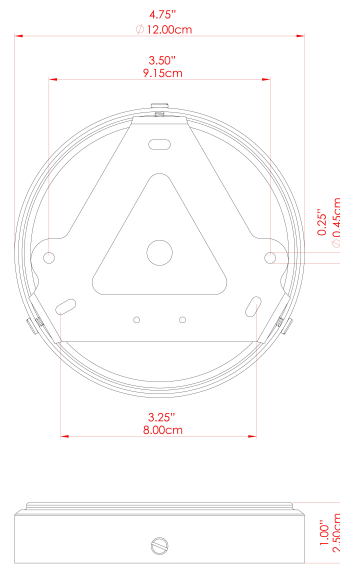

Product Notes:  
 1) Bulbs not included. 2) Dimensions do not include bulbs. 3) All products are individually made-to-order and therefore may differ slightly within manufacturing tolerances. 4) Cable / chain can be shortened during installation. Longer cable / chain lengths available on request. 5) Additional color finishes may be available on request. 6) Twisted cable is not available for UL wired products. Round cable in black or brown only is supplied instead. 7) Refer to our website for a full list of terms and conditions.



# RIVALE Ceramic Pendant

# MLCMP058ANTSLVCL Antique Silver

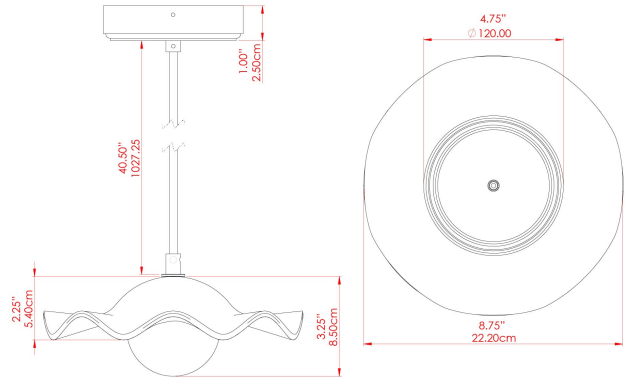

MATERIAL	Ceramic   Brass   Glass
HEIGHT	3.25"
WIDTH   DIAMETER	8.25"
LENGTH   PROJECTION	n/a
WEIGHT	0.6 kg   1.3 lbs
LAMPHOLDER	G9
MAX WATTAGE	6.5W
VOLTAGE	110/120v
ENVIRONMENTAL RATING	Dry Location (IP20)
CLASS PROTECTION	Class I
SHADE	GL196   MLCS061
FLEX   BAR   CHAIN LENGTH	40"
CABLE TYPE	MLCA028   Black Fabric Braided Cable   2 Core Round

### FIXING BRACKET: MLWB17

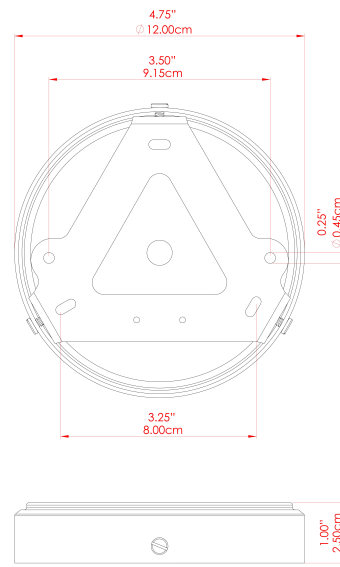

Product Notes:  
 1) Bulbs not included. 2) Dimensions do not include bulbs. 3) All products are individually made-to-order and therefore may differ slightly within manufacturing tolerances. 4) Cable / chain can be shortened during installation. Longer cable / chain lengths available on request. 5) Additional color finishes may be available on request. 6) Twisted cable is not available for UL wired products. Round cable in black or brown only is supplied instead. 7) Refer to our website for a full list of terms and conditions.





## RIVALE Ceramic Pendant

MLCMP058ANTSLVFR Antique Silver

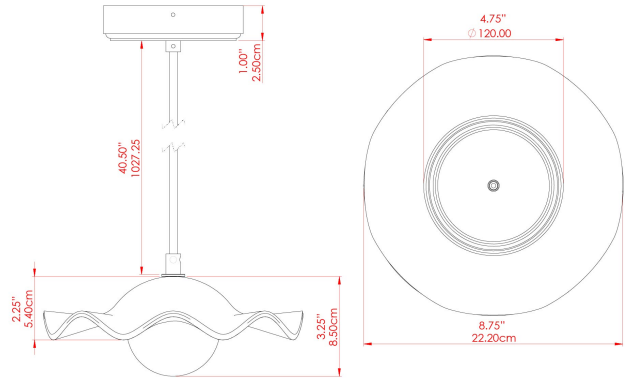

MATERIAL	Ceramic   Brass   Glass
HEIGHT	3.25"
WIDTH   DIAMETER	8.25"
LENGTH   PROJECTION	n/a
WEIGHT	0.6 kg   1.3 lbs
LAMPHOLDER	G9
MAX WATTAGE	6.5W
VOLTAGE	110/120v
ENVIRONMENTAL RATING	Dry Location (IP20)
CLASS PROTECTION	Class I
SHADE	GL208   MLCS061
FLEX   BAR   CHAIN LENGTH	40"
CABLE TYPE	MLCA028   Black Fabric Braided Cable   2 Core Round

FIXING BRACKET: MLWB17

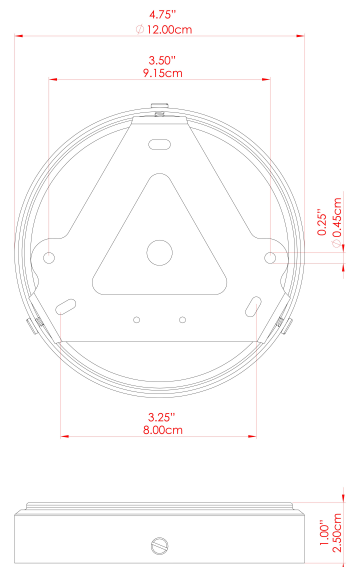

Product Notes:  
1) Bulbs not included. 2) Dimensions do not include bulbs. 3) All products are individually made-to-order and therefore may differ slightly within manufacturing tolerances. 4) Cable / chain can be shortened during installation. Longer cable / chain lengths available on request. 5) Additional color finishes may be available on request. 6) Twisted cable is not available for UL wired products. Round cable in black or brown only is supplied instead. 7) Refer to our website for a full list of terms and conditions.





# RIVALE Ceramic Pendant

MLCMP058ANTSLVOP Antique Silver

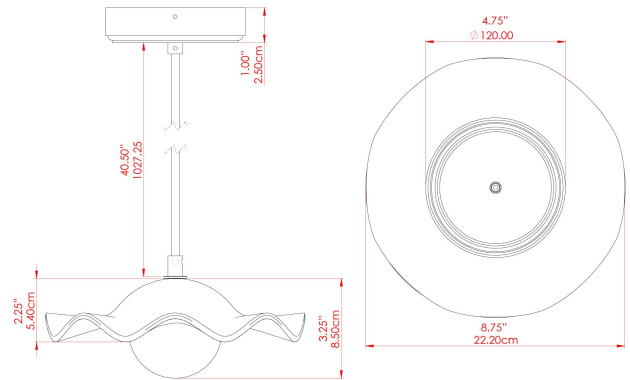

MATERIAL	Ceramic   Brass   Glass
HEIGHT	3.25"
WIDTH   DIAMETER	8.25"
LENGTH   PROJECTION	n/a
WEIGHT	0.6 kg   1.3 lbs
LAMPHOLDER	G9
MAX WATTAGE	6.5W
VOLTAGE	110/120v
ENVIRONMENTAL RATING	Dry Location (IP20)
CLASS PROTECTION	Class I
SHADE	GL192   MLCS061
FLEX   BAR   CHAIN LENGTH	40"
CABLE TYPE	MLCA028   Black Fabric Braided Cable   2 Core Round

## FIXING BRACKET: MLWB17

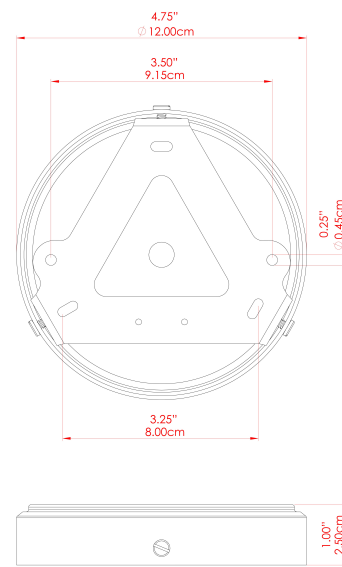

Product Notes:  
 1) Bulbs not included. 2) Dimensions do not include bulbs. 3) All products are individually made-to-order and therefore may differ slightly within manufacturing tolerances. 4) Cable / chain can be shortened during installation. Longer cable / chain lengths available on request. 5) Additional color finishes may be available on request. 6) Twisted cable is not available for UL wired products. Round cable in black or brown only is supplied instead. 7) Refer to our website for a full list of terms and conditions.







# RIVALE Ceramic Pendant

MLCMP058PCMBKOP Matt Black

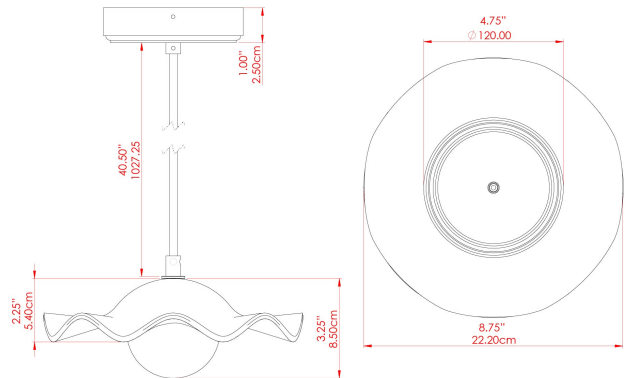

MATERIAL	Ceramic   Brass   Glass
HEIGHT	3.25"
WIDTH   DIAMETER	8.25"
LENGTH   PROJECTION	n/a
WEIGHT	0.6 kg   1.3 lbs
LAMPHOLDER	G9
MAX WATTAGE	6.5W
VOLTAGE	110/120v
ENVIRONMENTAL RATING	Dry Location (IP20)
CLASS PROTECTION	Class I
SHADE	GL192   MLCS061
FLEX   BAR   CHAIN LENGTH	40"
CABLE TYPE	MLCA028   Black Fabric Braided Cable   2 Core Round

FIXING BRACKET: MLWB17

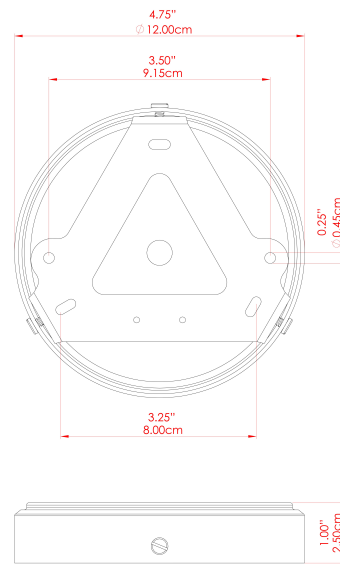

Product Notes:  
 1) Bulbs not included. 2) Dimensions do not include bulbs. 3) All products are individually made-to-order and therefore may differ slightly within manufacturing tolerances. 4) Cable / chain can be shortened during installation. Longer cable / chain lengths available on request. 5) Additional color finishes may be available on request. 6) Twisted cable is not available for UL wired products. Round cable in black or brown only is supplied instead. 7) Refer to our website for a full list of terms and conditions.





## RIVALE Ceramic Pendant

MLCMP058POLBRSCS Polished Brass

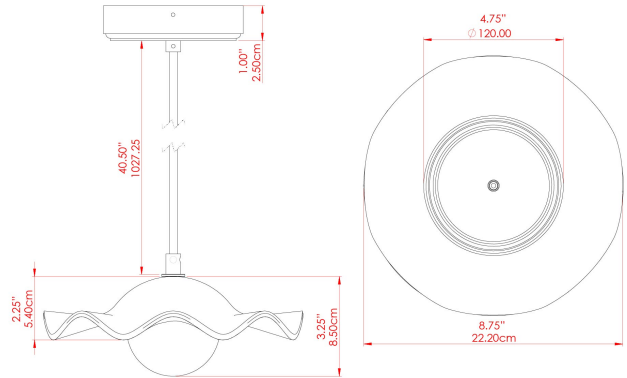

MATERIAL	Ceramic   Brass   Glass
HEIGHT	3.25"
WIDTH   DIAMETER	8.25"
LENGTH   PROJECTION	n/a
WEIGHT	0.6 kg   1.3 lbs
LAMPHOLDER	G9
MAX WATTAGE	6.5W
VOLTAGE	110/120v
ENVIRONMENTAL RATING	Dry Location (IP20)
CLASS PROTECTION	Class I
SHADE	GL196   MLCS061
FLEX   BAR   CHAIN LENGTH	40"
CABLE TYPE	MLCA028   Black Fabric Braided Cable   2 Core Round

FIXING BRACKET: MLWB17

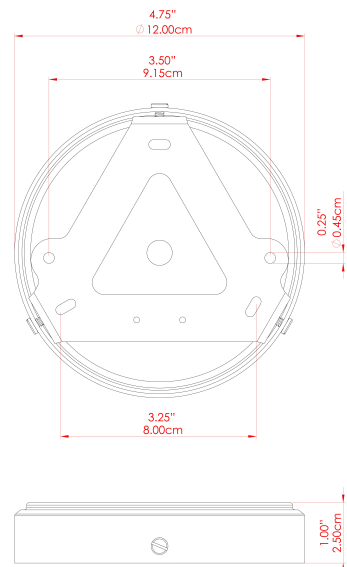

**Product Notes:**

1) Bulbs not included. 2) Dimensions do not include bulbs. 3) All products are individually made-to-order and therefore may differ slightly within manufacturing tolerances. 4) Cable / chain can be shortened during installation. Longer cable / chain lengths available on request. 5) Additional color finishes may be available on request. 6) Twisted cable is not available for UL wired products. Round cable in black or brown only is supplied instead. 7) Refer to our website for a full list of terms and conditions.







# RIVALE Ceramic Pendant

MLCMP058POLBRSFR Polished Brass

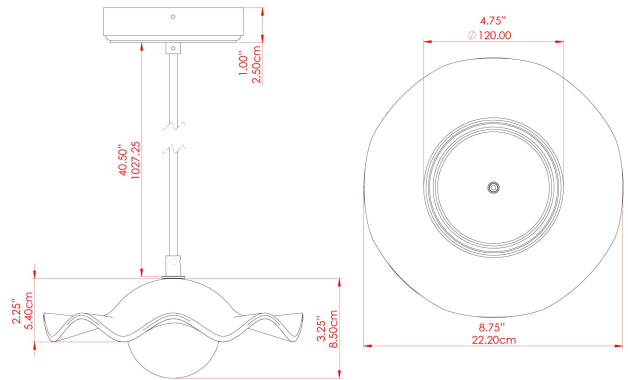

MATERIAL	Ceramic   Brass   Glass
HEIGHT	3.25"
WIDTH   DIAMETER	8.25"
LENGTH   PROJECTION	n/a
WEIGHT	0.6 kg   1.3 lbs
LAMPHOLDER	G9
MAX WATTAGE	6.5W
VOLTAGE	110/120v
ENVIRONMENTAL RATING	Dry Location (IP20)
CLASS PROTECTION	Class I
SHADE	GL208   MLCS061
FLEX   BAR   CHAIN LENGTH	40"
CABLE TYPE	MLCA028   Black Fabric Braided Cable   2 Core Round

FIXING BRACKET: MLWB17

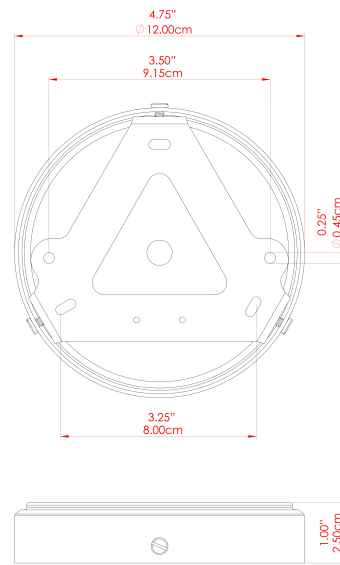

Product Notes:  
 1) Bulbs not included. 2) Dimensions do not include bulbs. 3) All products are individually made-to-order and therefore may differ slightly within manufacturing tolerances. 4) Cable / chain can be shortened during installation. Longer cable / chain lengths available on request. 5) Additional color finishes may be available on request. 6) Twisted cable is not available for UL wired products. Round cable in black or brown only is supplied instead. 7) Refer to our website for a full list of terms and conditions.





# RIVALE Ceramic Pendant

MLCMP058POLBRSOP Polished Brass

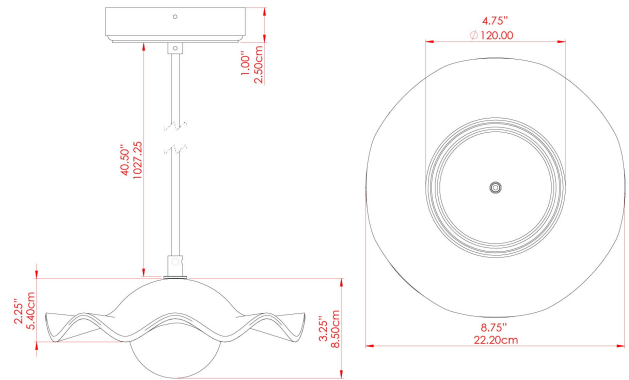

MATERIAL	Ceramic   Brass   Glass
HEIGHT	3.25"
WIDTH   DIAMETER	8.25"
LENGTH   PROJECTION	n/a
WEIGHT	0.6 kg   1.3 lbs
LAMPHOLDER	G9
MAX WATTAGE	6.5W
VOLTAGE	110/120v
ENVIRONMENTAL RATING	Dry Location (IP20)
CLASS PROTECTION	Class I
SHADE	GL192   MLCS061
FLEX   BAR   CHAIN LENGTH	40"
CABLE TYPE	MLCA028   Black Fabric Braided Cable   2 Core Round

### FIXING BRACKET: MLWB17

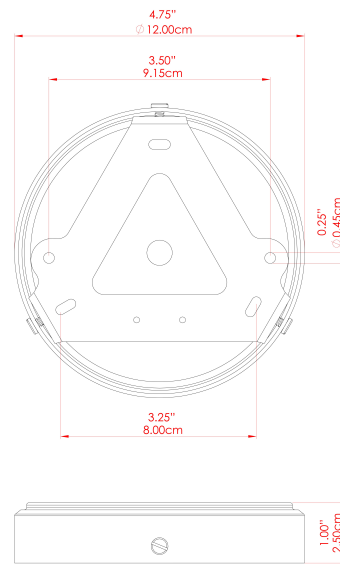

Product Notes:  
 1) Bulbs not included. 2) Dimensions do not include bulbs. 3) All products are individually made-to-order and therefore may differ slightly within manufacturing tolerances. 4) Cable / chain can be shortened during installation. Longer cable / chain lengths available on request. 5) Additional color finishes may be available on request. 6) Twisted cable is not available for UL wired products. Round cable in black or brown only is supplied instead. 7) Refer to our website for a full list of terms and conditions.



# RIVALE Ceramic Pendant

MLCMP058SATBRSL Satin Brass

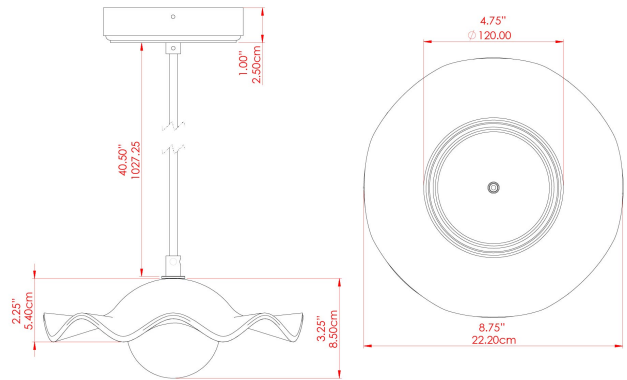

MATERIAL	Ceramic   Brass   Glass
HEIGHT	3.25"
WIDTH   DIAMETER	8.25"
LENGTH   PROJECTION	n/a
WEIGHT	0.6 kg   1.3 lbs
LAMPHOLDER	G9
MAX WATTAGE	6.5W
VOLTAGE	110/120v
ENVIRONMENTAL RATING	Dry Location (IP20)
CLASS PROTECTION	Class I
SHADE	GL196   MLCS061
FLEX   BAR   CHAIN LENGTH	40"
CABLE TYPE	MLCA028   Black Fabric Braided Cable   2 Core Round

### FIXING BRACKET: MLWB17

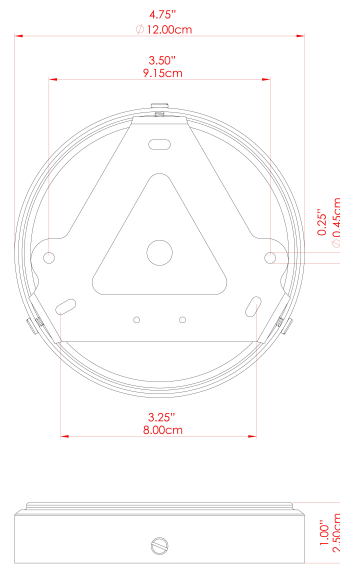

Product Notes:  
 1) Bulbs not included. 2) Dimensions do not include bulbs. 3) All products are individually made-to-order and therefore may differ slightly within manufacturing tolerances. 4) Cable / chain can be shortened during installation. Longer cable / chain lengths available on request. 5) Additional color finishes may be available on request. 6) Twisted cable is not available for UL wired products. Round cable in black or brown only is supplied instead. 7) Refer to our website for a full list of terms and conditions.





## RIVALE Ceramic Pendant

MLCMP058SATBRSFR Satin Brass

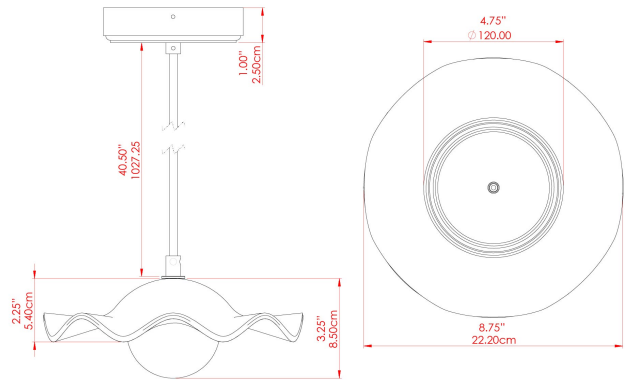

MATERIAL	Ceramic   Brass   Glass
HEIGHT	3.25"
WIDTH   DIAMETER	8.25"
LENGTH   PROJECTION	n/a
WEIGHT	0.6 kg   1.3 lbs
LAMPHOLDER	G9
MAX WATTAGE	6.5W
VOLTAGE	110/120v
ENVIRONMENTAL RATING	Dry Location (IP20)
CLASS PROTECTION	Class I
SHADE	GL208   MLCS061
FLEX   BAR   CHAIN LENGTH	40"
CABLE TYPE	MLCA028   Black Fabric Braided Cable   2 Core Round

### FIXING BRACKET: MLWB17

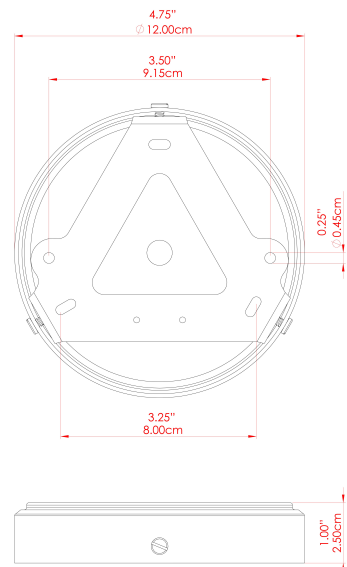

Product Notes:  
1) Bulbs not included. 2) Dimensions do not include bulbs. 3) All products are individually made-to-order and therefore may differ slightly within manufacturing tolerances. 4) Cable / chain can be shortened during installation. Longer cable / chain lengths available on request. 5) Additional color finishes may be available on request. 6) Twisted cable is not available for UL wired products. Round cable in black or brown only is supplied instead. 7) Refer to our website for a full list of terms and conditions.





# RIVALE Ceramic Pendant

MLCMP058SATBRSOP Satin Brass

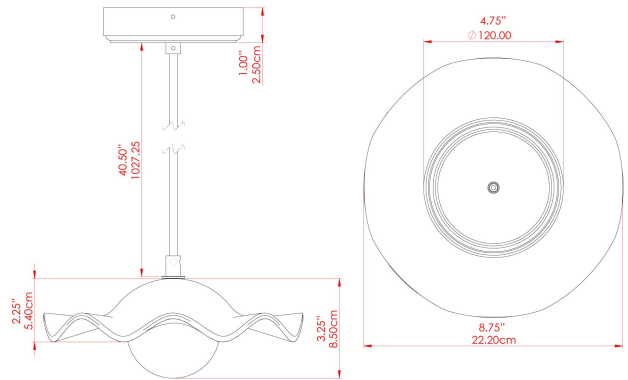

MATERIAL	Ceramic   Brass   Glass
HEIGHT	3.25"
WIDTH   DIAMETER	8.25"
LENGTH   PROJECTION	n/a
WEIGHT	0.6 kg   1.3 lbs
LAMPHOLDER	G9
MAX WATTAGE	6.5W
VOLTAGE	110/120v
ENVIRONMENTAL RATING	Dry Location (IP20)
CLASS PROTECTION	Class I
SHADE	GL192   MLCS061
FLEX   BAR   CHAIN LENGTH	40"
CABLE TYPE	MLCA028   Black Fabric Braided Cable   2 Core Round

FIXING BRACKET: MLWB17

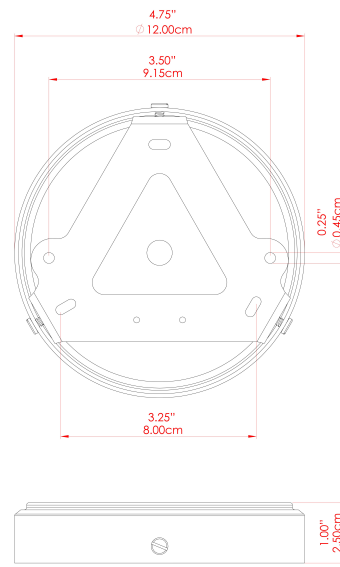

Product Notes:  
 1) Bulbs not included. 2) Dimensions do not include bulbs. 3) All products are individually made-to-order and therefore may differ slightly within manufacturing tolerances. 4) Cable / chain can be shortened during installation. Longer cable / chain lengths available on request. 5) Additional color finishes may be available on request. 6) Twisted cable is not available for UL wired products. Round cable in black or brown only is supplied instead. 7) Refer to our website for a full list of terms and conditions.

