

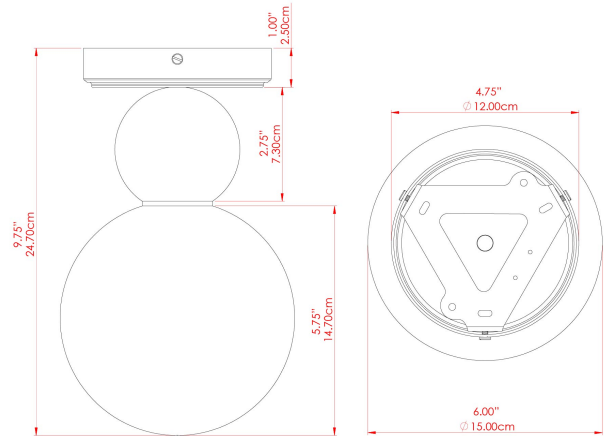

# HELENA Ceiling Light

# MLCF125ANTBRACL Antique Brass



MATERIAL	Brass   Glass
HEIGHT	6"
WIDTH   DIAMETER	6"
LENGTH   PROJECTION	9.75"
WEIGHT	0.92 kg   2 lbs
LAMPHOLDER	G9
MAX WATTAGE	6.5W
VOLTAGE	110/120v
ENVIRONMENTAL RATING	Dry Location (IP20)
CLASS PROTECTION	Class I
SHADE	GL170
FLEX   BAR   CHAIN LENGTH	n/a
CABLE TYPE	

## FIXING BRACKET: MLWB17 | Antique Brass

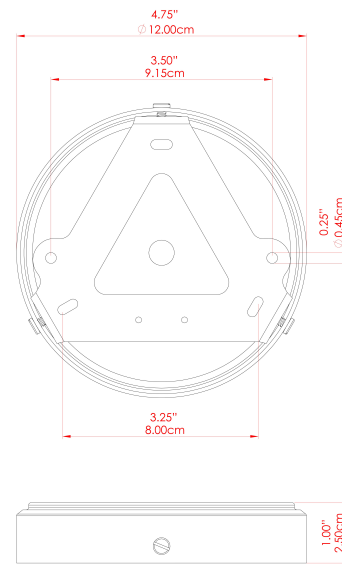

Product Notes:  
 1) Bulbs not included. 2) Dimensions do not include bulbs. 3) All products are individually made-to-order and therefore may differ slightly within manufacturing tolerances. 4) Cable / chain can be shortened during installation. Longer cable / chain lengths available on request. 5) Additional color finishes may be available on request. 6) Twisted cable is not available for UL wired products. Round cable in black or brown only is supplied instead. 7) Refer to our website for a full list of terms and conditions.



# HELENA Ceiling Light

## MLCF125ANTBRSFR Antique Brass

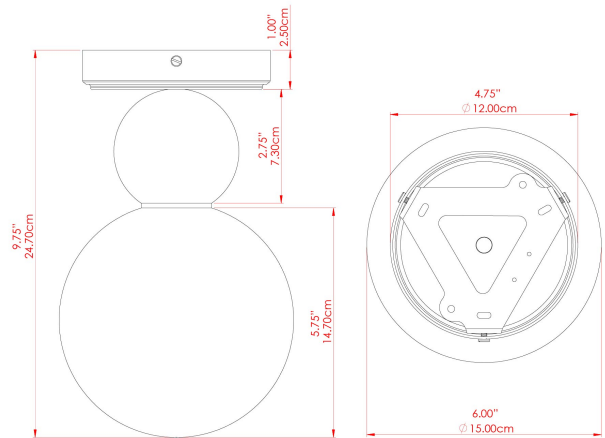

MATERIAL	Brass   Glass
HEIGHT	6"
WIDTH   DIAMETER	6"
LENGTH   PROJECTION	9.75"
WEIGHT	0.92 kg   2 lbs
LAMPHOLDER	G9
MAX WATTAGE	6.5W
VOLTAGE	110/120v
ENVIRONMENTAL RATING	Dry Location (IP20)
CLASS PROTECTION	Class I
SHADE	GL171
FLEX   BAR   CHAIN LENGTH	n/a
CABLE TYPE	

### FIXING BRACKET: MLWB17 |Antique Brass

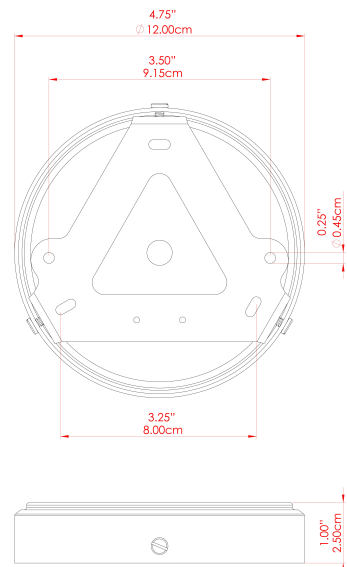

Product Notes:  
 1) Bulbs not included. 2) Dimensions do not include bulbs. 3) All products are individually made-to-order and therefore may differ slightly within manufacturing tolerances. 4) Cable / chain can be shortened during installation. Longer cable / chain lengths available on request. 5) Additional color finishes may be available on request. 6) Twisted cable is not available for UL wired products. Round cable in black or brown only is supplied instead. 7) Refer to our website for a full list of terms and conditions.





# HELENA Ceiling Light

# MLCF125ANTSLVCL Antique Silver

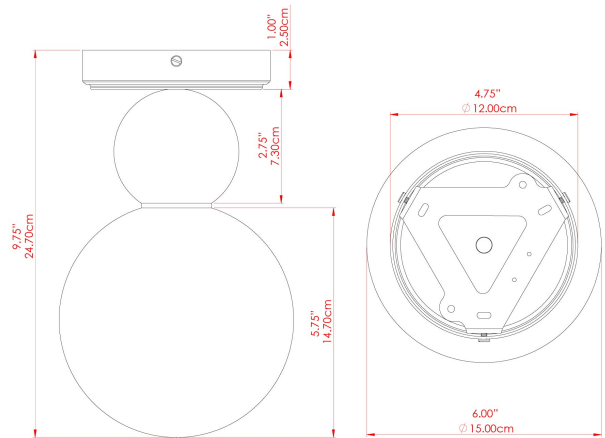

MATERIAL	Brass   Glass
HEIGHT	6"
WIDTH   DIAMETER	6"
LENGTH   PROJECTION	9.75"
WEIGHT	0.92 kg   2 lbs
LAMPHOLDER	G9
MAX WATTAGE	6.5W
VOLTAGE	110/120v
ENVIRONMENTAL RATING	Dry Location (IP20)
CLASS PROTECTION	Class I
SHADE	GL170
FLEX   BAR   CHAIN LENGTH	n/a
CABLE TYPE	

## FIXING BRACKET: MLWB17 |Antique Silver

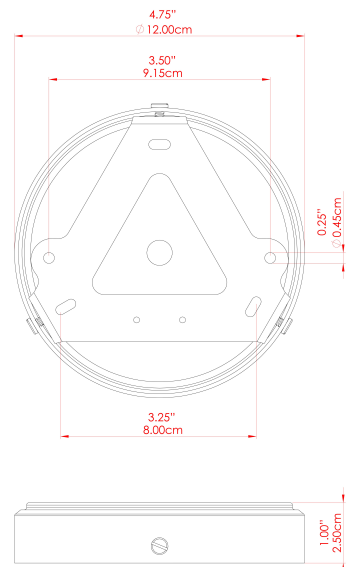

Product Notes:  
 1) Bulbs not included. 2) Dimensions do not include bulbs. 3) All products are individually made-to-order and therefore may differ slightly within manufacturing tolerances. 4) Cable / chain can be shortened during installation. Longer cable / chain lengths available on request. 5) Additional color finishes may be available on request. 6) Twisted cable is not available for UL wired products. Round cable in black or brown only is supplied instead. 7) Refer to our website for a full list of terms and conditions.





# HELENA Ceiling Light

# MLCF125ANTSLVFR Antique Silver

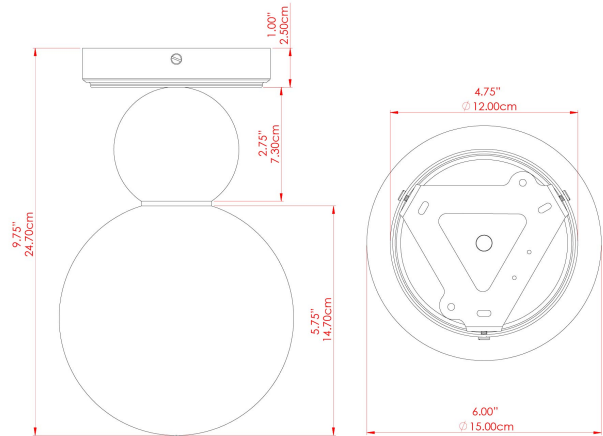

MATERIAL	Brass   Glass
HEIGHT	6"
WIDTH   DIAMETER	6"
LENGTH   PROJECTION	9.75"
WEIGHT	0.92 kg   2 lbs
LAMPHOLDER	G9
MAX WATTAGE	6.5W
VOLTAGE	110/120v
ENVIRONMENTAL RATING	Dry Location (IP20)
CLASS PROTECTION	Class I
SHADE	GL171
FLEX   BAR   CHAIN LENGTH	n/a
CABLE TYPE	

## FIXING BRACKET: MLWB17 | Antique Silver



Product Notes:  
 1) Bulbs not included. 2) Dimensions do not include bulbs. 3) All products are individually made-to-order and therefore may differ slightly within manufacturing tolerances. 4) Cable / chain can be shortened during installation. Longer cable / chain lengths available on request. 5) Additional color finishes may be available on request. 6) Twisted cable is not available for UL wired products. Round cable in black or brown only is supplied instead. 7) Refer to our website for a full list of terms and conditions.





## HELENA Ceiling Light

MLCF125POLBRSCS Polished Brass

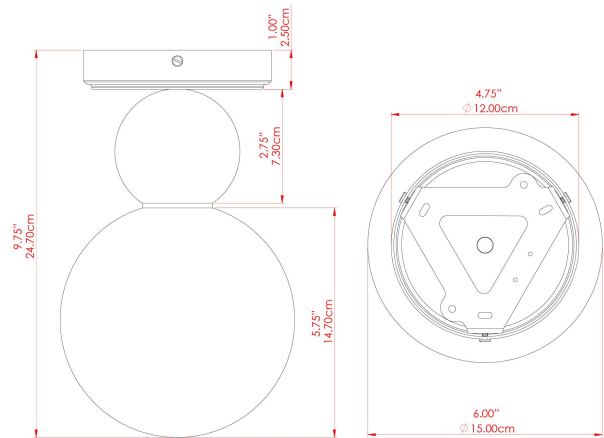

MATERIAL	Brass   Glass
HEIGHT	6"
WIDTH   DIAMETER	6"
LENGTH   PROJECTION	9.75"
WEIGHT	0.92 kg   2 lbs
LAMPHOLDER	G9
MAX WATTAGE	6.5W
VOLTAGE	110/120v
ENVIRONMENTAL RATING	Dry Location (IP20)
CLASS PROTECTION	Class I
SHADE	GL170
FLEX   BAR   CHAIN LENGTH	n/a
CABLE TYPE	

### FIXING BRACKET: MLWB17 | Polished Brass

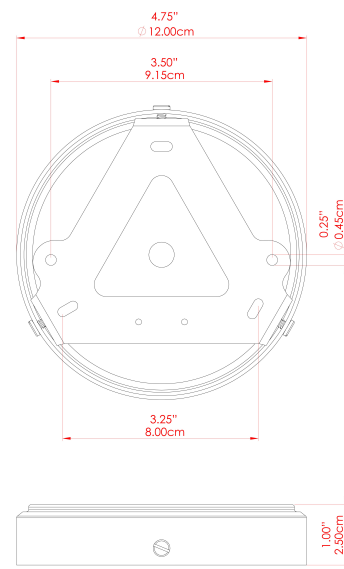

Product Notes:  
1) Bulbs not included. 2) Dimensions do not include bulbs. 3) All products are individually made-to-order and therefore may differ slightly within manufacturing tolerances. 4) Cable / chain can be shortened during installation. Longer cable / chain lengths available on request. 5) Additional color finishes may be available on request. 6) Twisted cable is not available for UL wired products. Round cable in black or brown only is supplied instead. 7) Refer to our website for a full list of terms and conditions.





# HELENA Ceiling Light

# MLCF125POLBRSFR Polished Brass

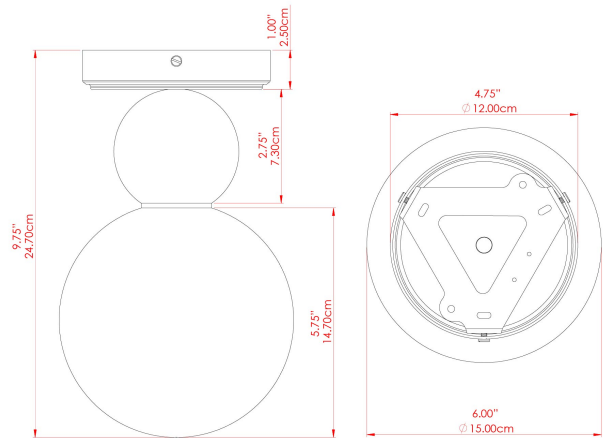

MATERIAL	Brass   Glass
HEIGHT	6"
WIDTH   DIAMETER	6"
LENGTH   PROJECTION	9.75"
WEIGHT	0.92 kg   2 lbs
LAMPHOLDER	G9
MAX WATTAGE	6.5W
VOLTAGE	110/120v
ENVIRONMENTAL RATING	Dry Location (IP20)
CLASS PROTECTION	Class I
SHADE	GL171
FLEX   BAR   CHAIN LENGTH	n/a
CABLE TYPE	

## FIXING BRACKET: MLWB17 | Polished Brass

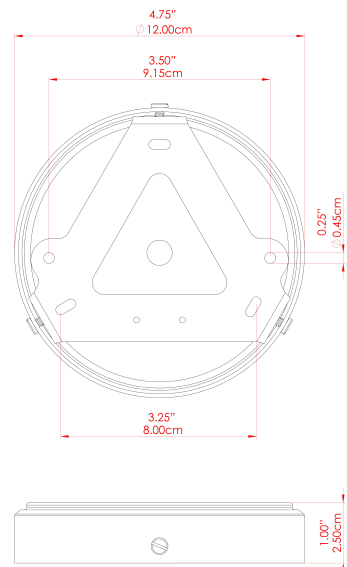

Product Notes:  
 1) Bulbs not included. 2) Dimensions do not include bulbs. 3) All products are individually made-to-order and therefore may differ slightly within manufacturing tolerances. 4) Cable / chain can be shortened during installation. Longer cable / chain lengths available on request. 5) Additional color finishes may be available on request. 6) Twisted cable is not available for UL wired products. Round cable in black or brown only is supplied instead. 7) Refer to our website for a full list of terms and conditions.





# HELENA Ceiling Light

MLCF125SATBRSL Satin Brass

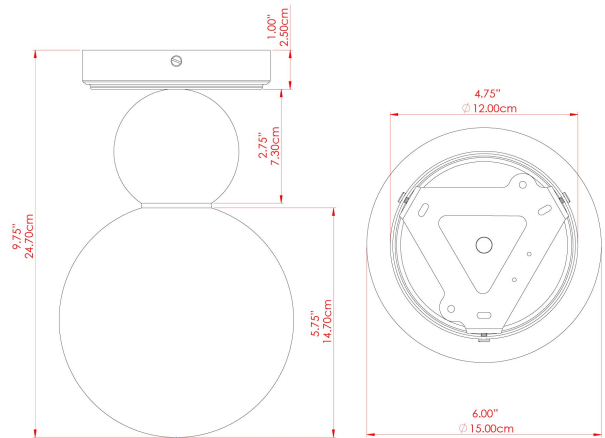

MATERIAL	Brass   Glass
HEIGHT	6"
WIDTH   DIAMETER	6"
LENGTH   PROJECTION	9.75"
WEIGHT	0.92 kg   2 lbs
LAMPHOLDER	G9
MAX WATTAGE	6.5W
VOLTAGE	110/120v
ENVIRONMENTAL RATING	Dry Location (IP20)
CLASS PROTECTION	Class I
SHADE	GL170
FLEX   BAR   CHAIN LENGTH	n/a
CABLE TYPE	

## FIXING BRACKET: MLWB17 | Satin Brass

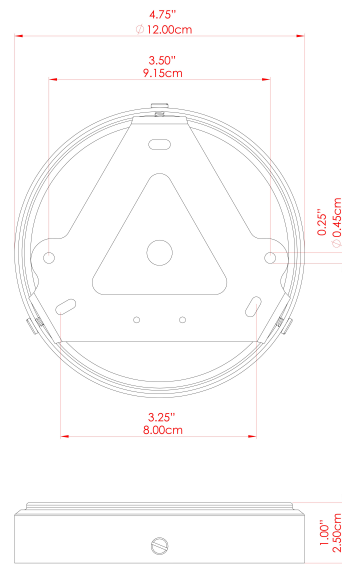

Product Notes:  
 1) Bulbs not included. 2) Dimensions do not include bulbs. 3) All products are individually made-to-order and therefore may differ slightly within manufacturing tolerances. 4) Cable / chain can be shortened during installation. Longer cable / chain lengths available on request. 5) Additional color finishes may be available on request. 6) Twisted cable is not available for UL wired products. Round cable in black or brown only is supplied instead. 7) Refer to our website for a full list of terms and conditions.





# HELENA Ceiling Light

MLCF125SATBRSFR Satin Brass

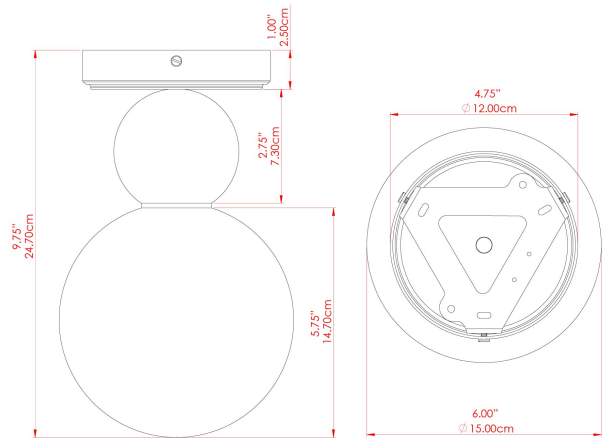

MATERIAL	Brass   Glass
HEIGHT	6"
WIDTH   DIAMETER	6"
LENGTH   PROJECTION	9.75"
WEIGHT	0.92 kg   2 lbs
LAMPHOLDER	G9
MAX WATTAGE	6.5W
VOLTAGE	110/120v
ENVIRONMENTAL RATING	Dry Location (IP20)
CLASS PROTECTION	Class I
SHADE	GL171
FLEX   BAR   CHAIN LENGTH	n/a
CABLE TYPE	

## FIXING BRACKET: MLWB17 | Satin Brass

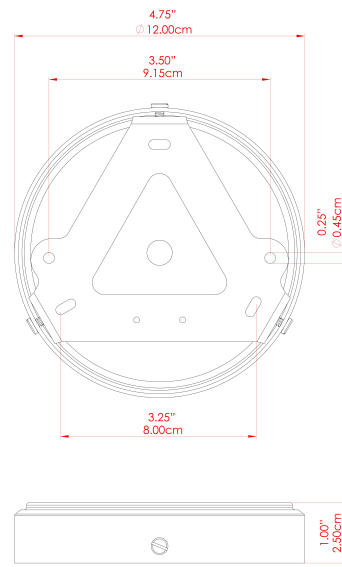

WWW.MULLANLIGHTING.COM

### Product Notes:

1) Bulbs not included. 2) Dimensions do not include bulbs. 3) All products are individually made-to-order and therefore may differ slightly within manufacturing tolerances. 4) Cable / chain can be shortened during installation. Longer cable / chain lengths available on request. 5) Additional color finishes may be available on request. 6) Twisted cable is not available for UL wired products. Round cable in black or brown only is supplied instead. 7) Refer to our website for a full list of terms and conditions.

