

MATERIAL	Brass Aluminium
HEIGHT	8.75"
WIDTH DIAMETER	11.75"
LENGTH PROJECTION	n/a
WEIGHT	0.46 kg 1 lbs
LAMPHOLDER	E26
MAX WATTAGE	60W
VOLTAGE	110/120v
ENVIRONMENTAL RATING	Dry Location (IP20)
CLASS PROTECTION	Class I
SHADE	-
FLEX BAR CHAIN LENGTH	40"
CABLE TYPE	MLCA020 Black Fabric Braided Cable 3 Core Twisted

FIXING BRACKET: MLROSE39 | Polished Chrome

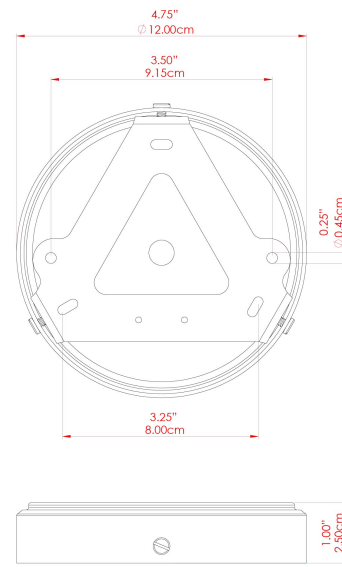

Product Notes:

1) Bulbs not included. 2) Dimensions do not include bulbs. 3) All products are individually made-to-order and therefore may differ slightly within manufacturing tolerances. 4) Cable / chain can be shortened during installation. Longer cable / chain lengths available on request. 5) Additional color finishes may be available on request. 6) Twisted cable is not available for UL wired products. Round cable in black or brown only is supplied instead. 7) Refer to our website for a full list of terms and conditions.



WWW.MULLANLIGHTING.COM



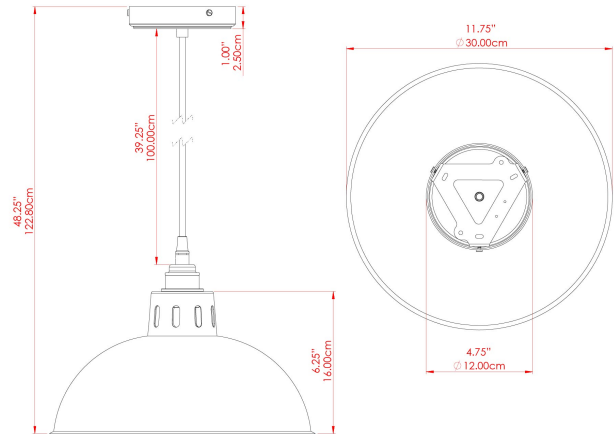

MATERIAL	Brass Aluminium
HEIGHT	8.75"
WIDTH DIAMETER	11.75"
LENGTH PROJECTION	n/a
WEIGHT	0.46 kg 1 lbs
LAMPHOLDER	E26
MAX WATTAGE	60W
VOLTAGE	110/120v
ENVIRONMENTAL RATING	Dry Location (IP20)
CLASS PROTECTION	Class I
SHADE	-
FLEX BAR CHAIN LENGTH	40"
CABLE TYPE	MLCA072 Brown Fabric Braided Cable 2 Core Round UL

FIXING BRACKET: MLROSE39 | Antique Brass

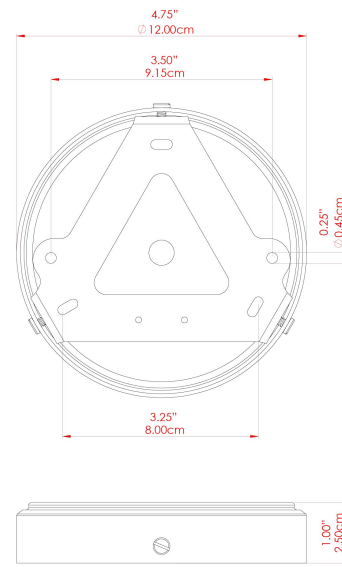

Product Notes:
 1) Bulbs not included. 2) Dimensions do not include bulbs. 3) All products are individually made-to-order and therefore may differ slightly within manufacturing tolerances. 4) Cable / chain can be shortened during installation. Longer cable / chain lengths available on request. 5) Additional color finishes may be available on request. 6) Twisted cable is not available for UL wired products. Round cable in black or brown only is supplied instead. 7) Refer to our website for a full list of terms and conditions.



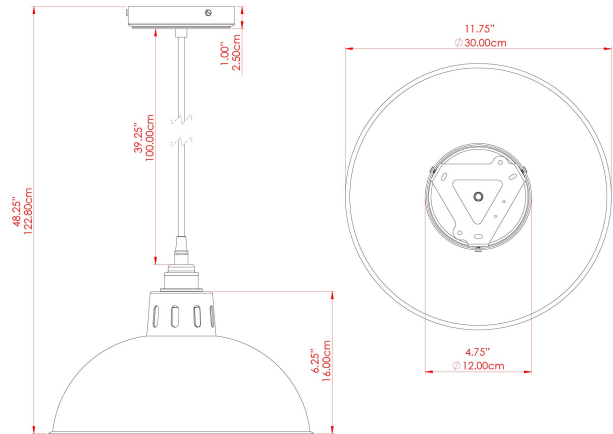

MATERIAL	Brass Aluminium
HEIGHT	8.75"
WIDTH DIAMETER	11.75"
LENGTH PROJECTION	n/a
WEIGHT	0.46 kg 1 lbs
LAMPHOLDER	E26
MAX WATTAGE	60W
VOLTAGE	110/120v
ENVIRONMENTAL RATING	Dry Location (IP20)
CLASS PROTECTION	Class I
SHADE	-
FLEX BAR CHAIN LENGTH	40"
CABLE TYPE	MLCA020 Black Fabric Braided Cable 3 Core Twisted

FIXING BRACKET: MLROSE39 | Polished Chrome

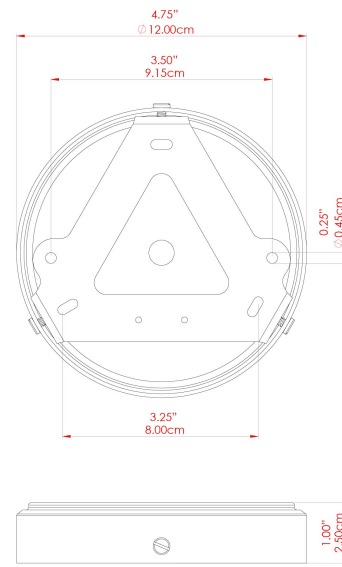

Product Notes:
 1) Bulbs not included. 2) Dimensions do not include bulbs. 3) All products are individually made-to-order and therefore may differ slightly within manufacturing tolerances. 4) Cable / chain can be shortened during installation. Longer cable / chain lengths available on request. 5) Additional color finishes may be available on request. 6) Twisted cable is not available for UL wired products. Round cable in black or brown only is supplied instead. 7) Refer to our website for a full list of terms and conditions.



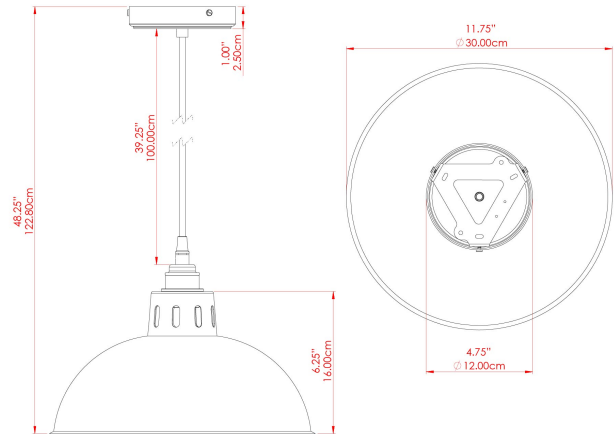

MATERIAL	Brass Aluminium
HEIGHT	8.75"
WIDTH DIAMETER	11.75"
LENGTH PROJECTION	n/a
WEIGHT	0.46 kg 1 lbs
LAMPHOLDER	E26
MAX WATTAGE	60W
VOLTAGE	110/120v
ENVIRONMENTAL RATING	Dry Location (IP20)
CLASS PROTECTION	Class I
SHADE	-
FLEX BAR CHAIN LENGTH	40"
CABLE TYPE	MLCA020 Black Fabric Braided Cable 3 Core Twisted

FIXING BRACKET: MLROSE39 | Polished Chrome

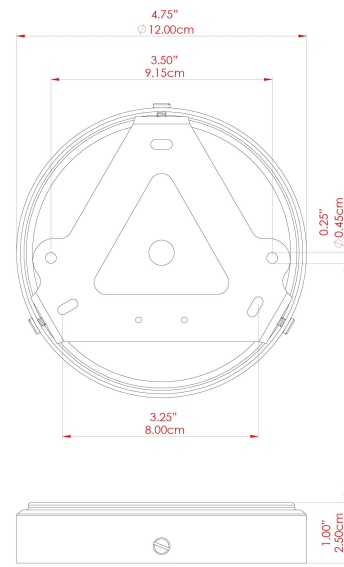

Product Notes:
 1) Bulbs not included. 2) Dimensions do not include bulbs. 3) All products are individually made-to-order and therefore may differ slightly within manufacturing tolerances. 4) Cable / chain can be shortened during installation. Longer cable / chain lengths available on request. 5) Additional color finishes may be available on request. 6) Twisted cable is not available for UL wired products. Round cable in black or brown only is supplied instead. 7) Refer to our website for a full list of terms and conditions.



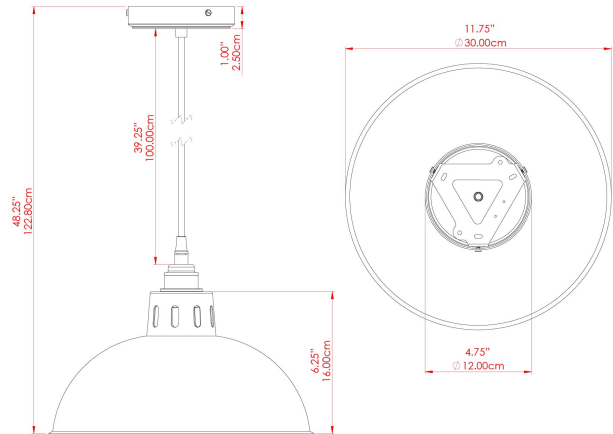

MATERIAL	Brass Aluminium
HEIGHT	8.75"
WIDTH DIAMETER	11.75"
LENGTH PROJECTION	n/a
WEIGHT	0.46 kg 1 lbs
LAMPHOLDER	E26
MAX WATTAGE	60W
VOLTAGE	110/120v
ENVIRONMENTAL RATING	Dry Location (IP20)
CLASS PROTECTION	Class I
SHADE	-
FLEX BAR CHAIN LENGTH	40"
CABLE TYPE	MLCA020 Black Fabric Braided Cable 3 Core Twisted

FIXING BRACKET: MLROSE39 | Polished Chrome

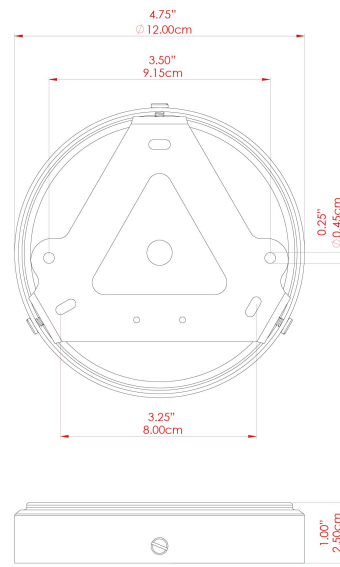

Product Notes:

1) Bulbs not included. 2) Dimensions do not include bulbs. 3) All products are individually made-to-order and therefore may differ slightly within manufacturing tolerances. 4) Cable / chain can be shortened during installation. Longer cable / chain lengths available on request. 5) Additional color finishes may be available on request. 6) Twisted cable is not available for UL wired products. Round cable in black or brown only is supplied instead. 7) Refer to our website for a full list of terms and conditions.



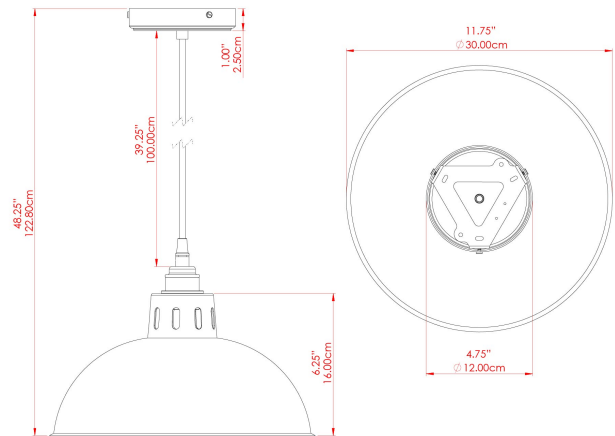

MATERIAL	Brass Aluminium
HEIGHT	8.75"
WIDTH DIAMETER	11.75"
LENGTH PROJECTION	n/a
WEIGHT	0.46 kg 1 lbs
LAMPHOLDER	E26
MAX WATTAGE	60W
VOLTAGE	110/120v
ENVIRONMENTAL RATING	Dry Location (IP20)
CLASS PROTECTION	Class I
SHADE	-
FLEX BAR CHAIN LENGTH	40"
CABLE TYPE	MLCA020 Black Fabric Braided Cable 3 Core Twisted

FIXING BRACKET: MLROSE39 | Polished Chrome

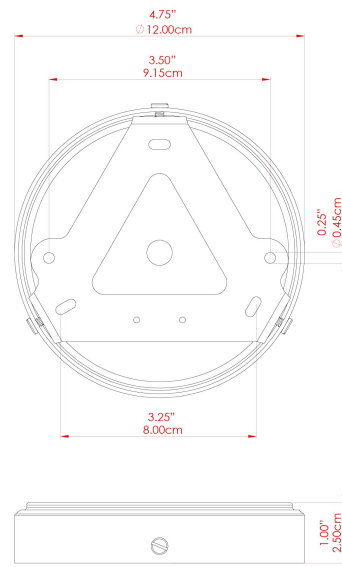

Product Notes:
 1) Bulbs not included. 2) Dimensions do not include bulbs. 3) All products are individually made-to-order and therefore may differ slightly within manufacturing tolerances. 4) Cable / chain can be shortened during installation. Longer cable / chain lengths available on request. 5) Additional color finishes may be available on request. 6) Twisted cable is not available for UL wired products. Round cable in black or brown only is supplied instead. 7) Refer to our website for a full list of terms and conditions.



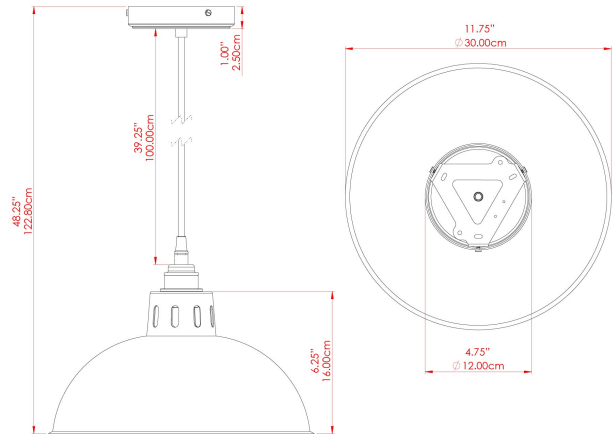

MATERIAL	Brass Aluminium
HEIGHT	8.75"
WIDTH DIAMETER	11.75"
LENGTH PROJECTION	n/a
WEIGHT	0.46 kg 1 lbs
LAMPHOLDER	E26
MAX WATTAGE	60W
VOLTAGE	110/120v
ENVIRONMENTAL RATING	Dry Location (IP20)
CLASS PROTECTION	Class I
SHADE	-
FLEX BAR CHAIN LENGTH	40"
CABLE TYPE	MLCA020 Black Fabric Braided Cable 3 Core Twisted

FIXING BRACKET: MLROSE39 | Polished Chrome

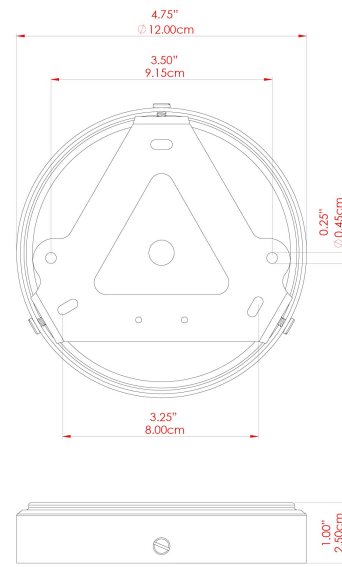

Product Notes:
 1) Bulbs not included. 2) Dimensions do not include bulbs. 3) All products are individually made-to-order and therefore may differ slightly within manufacturing tolerances. 4) Cable / chain can be shortened during installation. Longer cable / chain lengths available on request. 5) Additional color finishes may be available on request. 6) Twisted cable is not available for UL wired products. Round cable in black or brown only is supplied instead. 7) Refer to our website for a full list of terms and conditions.



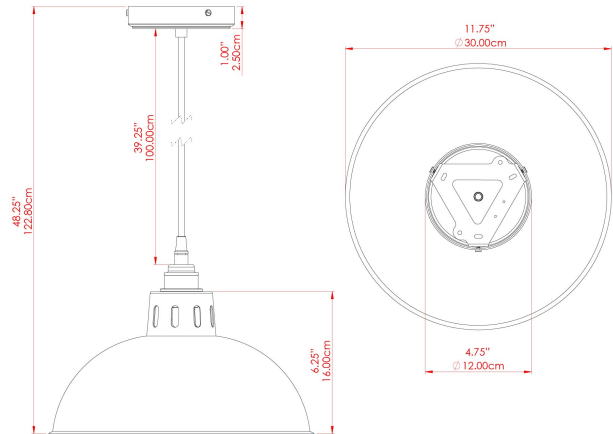

MATERIAL	Brass Aluminium
HEIGHT	8.75"
WIDTH DIAMETER	11.75"
LENGTH PROJECTION	n/a
WEIGHT	0.46 kg 1 lbs
LAMPHOLDER	E26
MAX WATTAGE	60W
VOLTAGE	110/120v
ENVIRONMENTAL RATING	Dry Location (IP20)
CLASS PROTECTION	Class I
SHADE	-
FLEX BAR CHAIN LENGTH	40"
CABLE TYPE	MLCA020 Black Fabric Braided Cable 3 Core Twisted

FIXING BRACKET: MLROSE39 | Polished Chrome

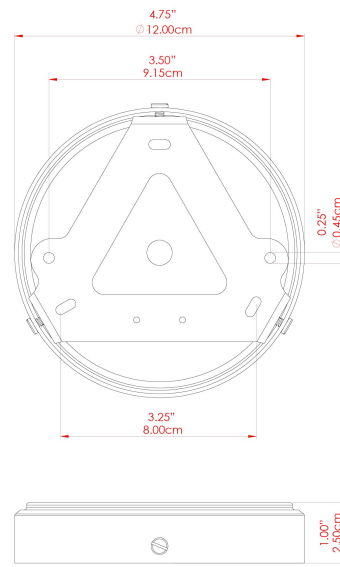

Product Notes:
 1) Bulbs not included. 2) Dimensions do not include bulbs. 3) All products are individually made-to-order and therefore may differ slightly within manufacturing tolerances. 4) Cable / chain can be shortened during installation. Longer cable / chain lengths available on request. 5) Additional color finishes may be available on request. 6) Twisted cable is not available for UL wired products. Round cable in black or brown only is supplied instead. 7) Refer to our website for a full list of terms and conditions.



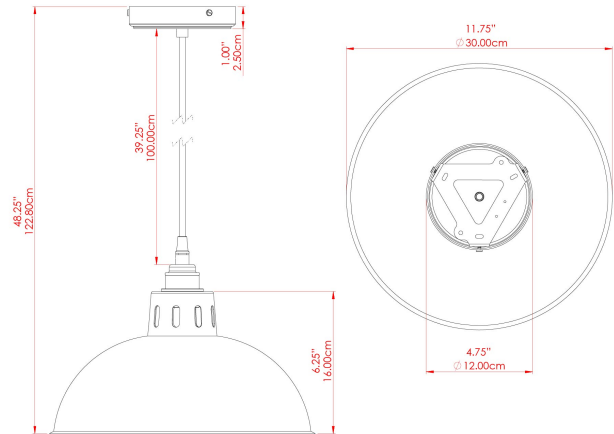

MATERIAL	Brass Aluminium
HEIGHT	8.75"
WIDTH DIAMETER	11.75"
LENGTH PROJECTION	n/a
WEIGHT	0.46 kg 1 lbs
LAMPHOLDER	E26
MAX WATTAGE	60W
VOLTAGE	110/120v
ENVIRONMENTAL RATING	Dry Location (IP20)
CLASS PROTECTION	Class I
SHADE	-
FLEX BAR CHAIN LENGTH	40"
CABLE TYPE	MLCA020 Black Fabric Braided Cable 3 Core Twisted

FIXING BRACKET: MLROSE39 | Polished Chrome

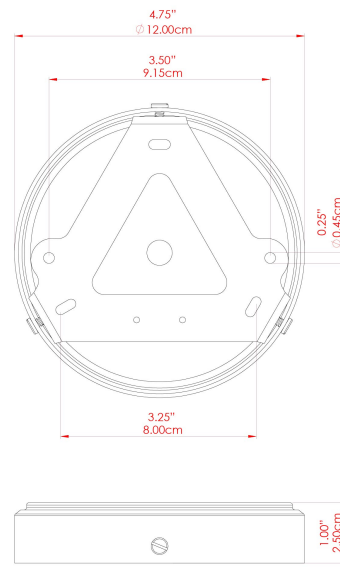

Product Notes:
 1) Bulbs not included. 2) Dimensions do not include bulbs. 3) All products are individually made-to-order and therefore may differ slightly within manufacturing tolerances. 4) Cable / chain can be shortened during installation. Longer cable / chain lengths available on request. 5) Additional color finishes may be available on request. 6) Twisted cable is not available for UL wired products. Round cable in black or brown only is supplied instead. 7) Refer to our website for a full list of terms and conditions.



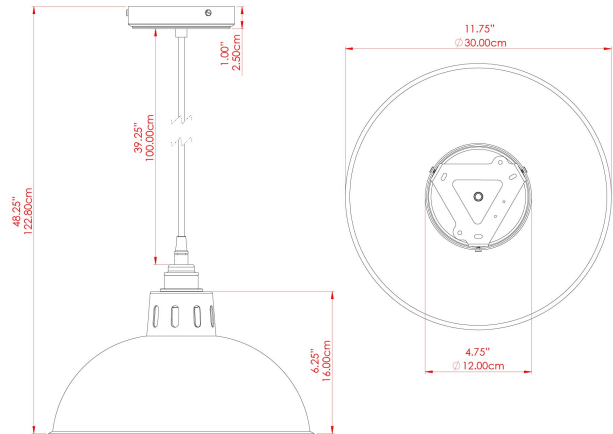

MATERIAL	Brass Aluminium
HEIGHT	8.75"
WIDTH DIAMETER	11.75"
LENGTH PROJECTION	n/a
WEIGHT	0.46 kg 1 lbs
LAMPHOLDER	E26
MAX WATTAGE	60W
VOLTAGE	110/120v
ENVIRONMENTAL RATING	Dry Location (IP20)
CLASS PROTECTION	Class I
SHADE	-
FLEX BAR CHAIN LENGTH	40"
CABLE TYPE	MLCA020 Black Fabric Braided Cable 3 Core Twisted

FIXING BRACKET: MLROSE39 | Polished Chrome

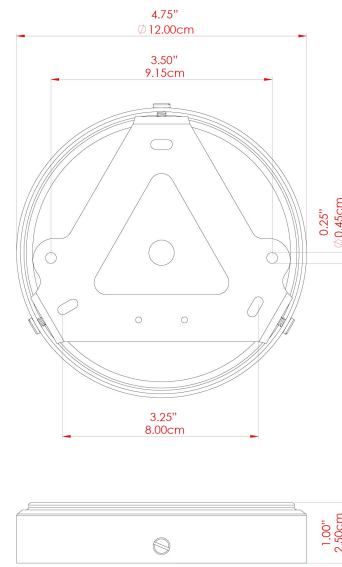

Product Notes:

1) Bulbs not included. 2) Dimensions do not include bulbs. 3) All products are individually made-to-order and therefore may differ slightly within manufacturing tolerances. 4) Cable / chain can be shortened during installation. Longer cable / chain lengths available on request. 5) Additional color finishes may be available on request. 6) Twisted cable is not available for UL wired products. Round cable in black or brown only is supplied instead. 7) Refer to our website for a full list of terms and conditions.



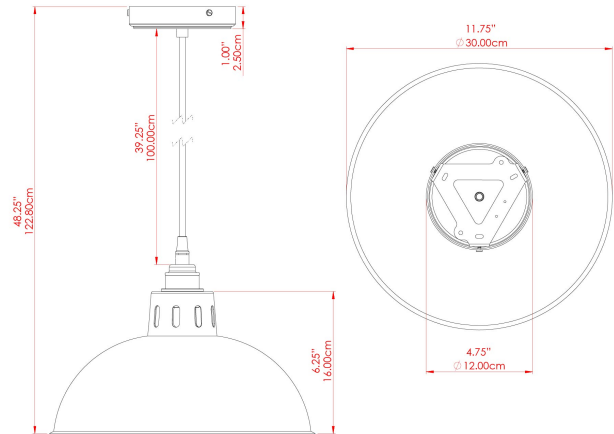

MATERIAL	Brass Aluminium
HEIGHT	8.75"
WIDTH DIAMETER	11.75"
LENGTH PROJECTION	n/a
WEIGHT	0.46 kg 1 lbs
LAMPHOLDER	E26
MAX WATTAGE	60W
VOLTAGE	110/120v
ENVIRONMENTAL RATING	Dry Location (IP20)
CLASS PROTECTION	Class I
SHADE	-
FLEX BAR CHAIN LENGTH	40"
CABLE TYPE	MLCA020 Black Fabric Braided Cable 3 Core Twisted

FIXING BRACKET: MLROSE39 | Polished Chrome

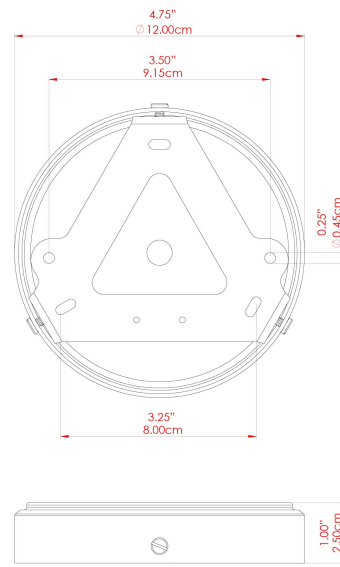

Product Notes:
 1) Bulbs not included. 2) Dimensions do not include bulbs. 3) All products are individually made-to-order and therefore may differ slightly within manufacturing tolerances. 4) Cable / chain can be shortened during installation. Longer cable / chain lengths available on request. 5) Additional color finishes may be available on request. 6) Twisted cable is not available for UL wired products. Round cable in black or brown only is supplied instead. 7) Refer to our website for a full list of terms and conditions.



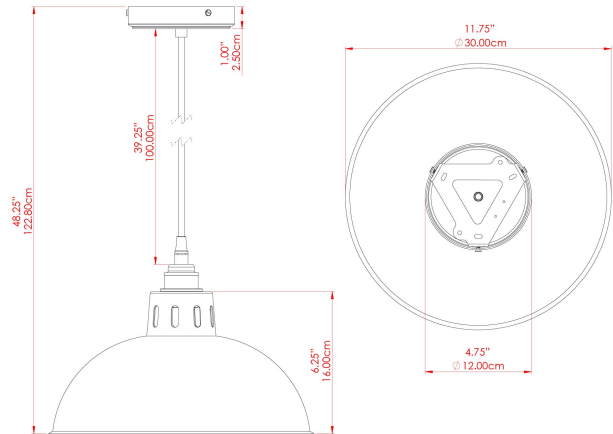

MATERIAL	Brass Aluminium
HEIGHT	8.75"
WIDTH DIAMETER	11.75"
LENGTH PROJECTION	n/a
WEIGHT	0.46 kg 1 lbs
LAMPHOLDER	E26
MAX WATTAGE	60W
VOLTAGE	110/120v
ENVIRONMENTAL RATING	Dry Location (IP20)
CLASS PROTECTION	Class I
SHADE	-
FLEX BAR CHAIN LENGTH	40"
CABLE TYPE	MLCA020 Black Fabric Braided Cable 3 Core Twisted

FIXING BRACKET: MLROSE39 | Polished Chrome

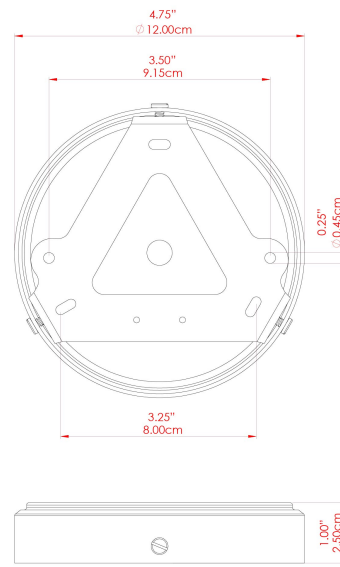

Product Notes:

1) Bulbs not included. 2) Dimensions do not include bulbs. 3) All products are individually made-to-order and therefore may differ slightly within manufacturing tolerances. 4) Cable / chain can be shortened during installation. Longer cable / chain lengths available on request. 5) Additional color finishes may be available on request. 6) Twisted cable is not available for UL wired products. Round cable in black or brown only is supplied instead. 7) Refer to our website for a full list of terms and conditions.



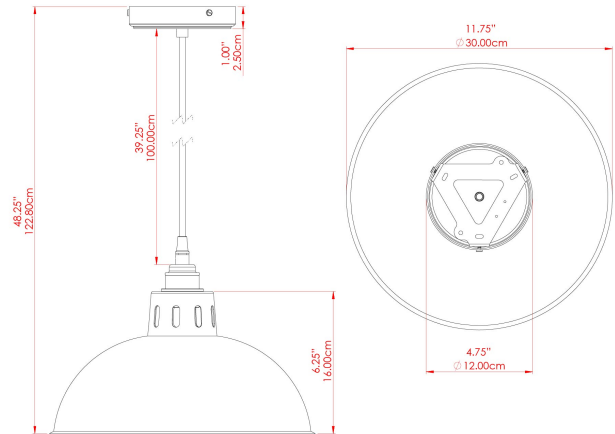

MATERIAL	Brass Aluminium
HEIGHT	8.75"
WIDTH DIAMETER	11.75"
LENGTH PROJECTION	n/a
WEIGHT	0.46 kg 1 lbs
LAMPHOLDER	E26
MAX WATTAGE	60W
VOLTAGE	110/120v
ENVIRONMENTAL RATING	Dry Location (IP20)
CLASS PROTECTION	Class I
SHADE	-
FLEX BAR CHAIN LENGTH	40"
CABLE TYPE	MLCA020 Black Fabric Braided Cable 3 Core Twisted

FIXING BRACKET: MLROSE39 | Polished Chrome

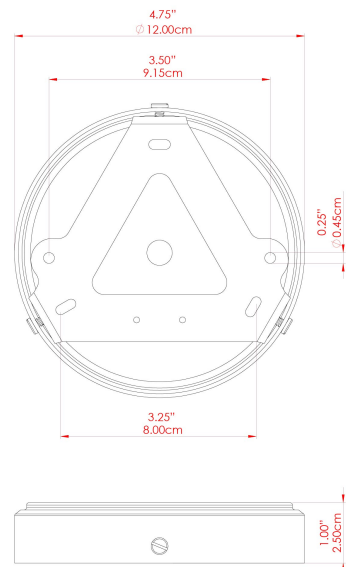

Product Notes:
 1) Bulbs not included. 2) Dimensions do not include bulbs. 3) All products are individually made-to-order and therefore may differ slightly within manufacturing tolerances. 4) Cable / chain can be shortened during installation. Longer cable / chain lengths available on request. 5) Additional color finishes may be available on request. 6) Twisted cable is not available for UL wired products. Round cable in black or brown only is supplied instead. 7) Refer to our website for a full list of terms and conditions.



OSSON Pendant

MLP262PCRGR Racing Green

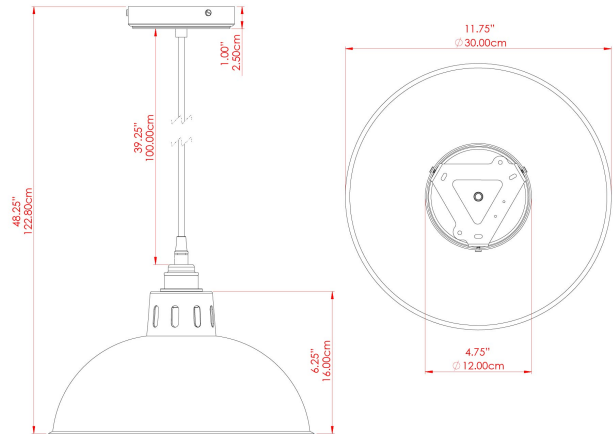

MATERIAL	Brass Aluminium
HEIGHT	8.75"
WIDTH DIAMETER	11.75"
LENGTH PROJECTION	n/a
WEIGHT	0.46 kg 1 lbs
LAMPHOLDER	E26
MAX WATTAGE	60W
VOLTAGE	110/120v
ENVIRONMENTAL RATING	Dry Location (IP20)
CLASS PROTECTION	Class I
SHADE	-
FLEX BAR CHAIN LENGTH	40"
CABLE TYPE	MLCA020 Black Fabric Braided Cable 3 Core Twisted

FIXING BRACKET: MLROSE39 | Polished Chrome

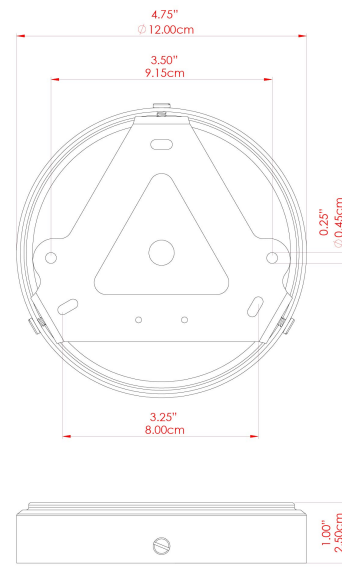

Product Notes:
 1) Bulbs not included. 2) Dimensions do not include bulbs. 3) All products are individually made-to-order and therefore may differ slightly within manufacturing tolerances. 4) Cable / chain can be shortened during installation. Longer cable / chain lengths available on request. 5) Additional color finishes may be available on request. 6) Twisted cable is not available for UL wired products. Round cable in black or brown only is supplied instead. 7) Refer to our website for a full list of terms and conditions.



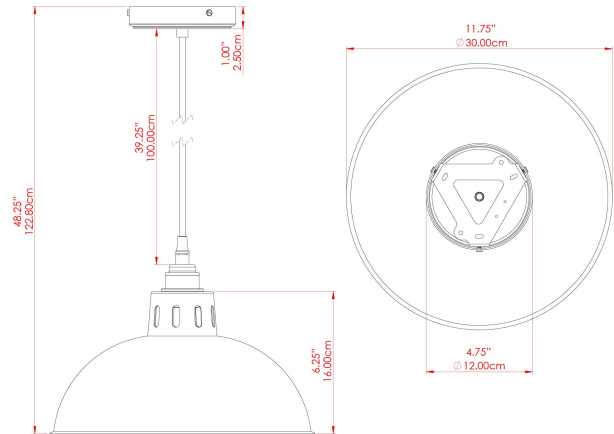

MATERIAL	Brass Aluminium
HEIGHT	8.75"
WIDTH DIAMETER	11.75"
LENGTH PROJECTION	n/a
WEIGHT	0.46 kg 1 lbs
LAMPHOLDER	E26
MAX WATTAGE	60W
VOLTAGE	110/120v
ENVIRONMENTAL RATING	Dry Location (IP20)
CLASS PROTECTION	Class I
SHADE	-
FLEX BAR CHAIN LENGTH	40"
CABLE TYPE	MLCA020 Black Fabric Braided Cable 3 Core Twisted

FIXING BRACKET: MLROSE39 | Polished Chrome

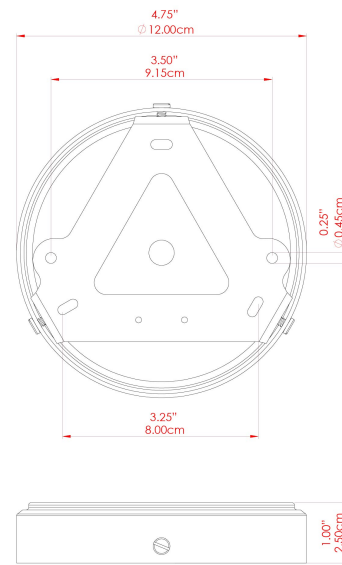

Product Notes:
 1) Bulbs not included. 2) Dimensions do not include bulbs. 3) All products are individually made-to-order and therefore may differ slightly within manufacturing tolerances. 4) Cable / chain can be shortened during installation. Longer cable / chain lengths available on request. 5) Additional color finishes may be available on request. 6) Twisted cable is not available for UL wired products. Round cable in black or brown only is supplied instead. 7) Refer to our website for a full list of terms and conditions.



OSSON Pendant

MLP262PCGRN Sage Green

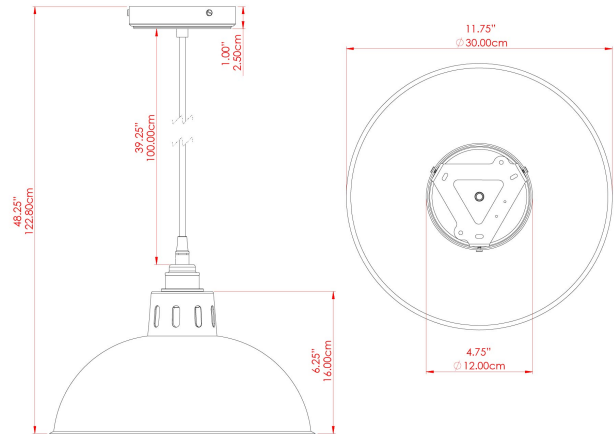

MATERIAL	Brass Aluminium
HEIGHT	8.75"
WIDTH DIAMETER	11.75"
LENGTH PROJECTION	n/a
WEIGHT	0.46 kg 1 lbs
LAMPHOLDER	E26
MAX WATTAGE	60W
VOLTAGE	110/120v
ENVIRONMENTAL RATING	Dry Location (IP20)
CLASS PROTECTION	Class I
SHADE	-
FLEX BAR CHAIN LENGTH	40"
CABLE TYPE	MLCA020 Black Fabric Braided Cable 3 Core Twisted

FIXING BRACKET: MLROSE39 | Polished Chrome

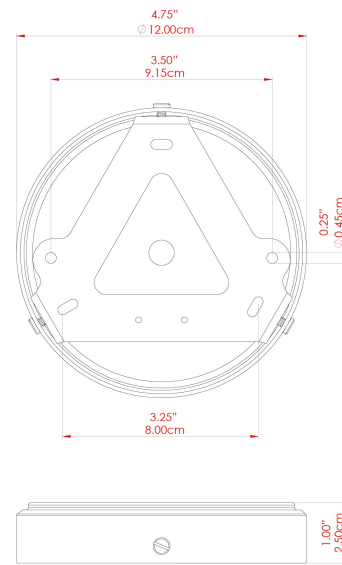

Product Notes:
 1) Bulbs not included. 2) Dimensions do not include bulbs. 3) All products are individually made-to-order and therefore may differ slightly within manufacturing tolerances. 4) Cable / chain can be shortened during installation. Longer cable / chain lengths available on request. 5) Additional color finishes may be available on request. 6) Twisted cable is not available for UL wired products. Round cable in black or brown only is supplied instead. 7) Refer to our website for a full list of terms and conditions.



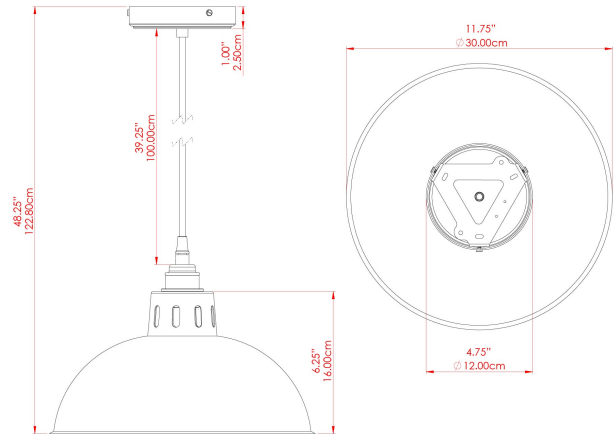

MATERIAL	Brass Aluminium
HEIGHT	8.75"
WIDTH DIAMETER	11.75"
LENGTH PROJECTION	n/a
WEIGHT	0.46 kg 1 lbs
LAMPHOLDER	E26
MAX WATTAGE	60W
VOLTAGE	110/120v
ENVIRONMENTAL RATING	Dry Location (IP20)
CLASS PROTECTION	Class I
SHADE	-
FLEX BAR CHAIN LENGTH	40"
CABLE TYPE	MLCA020 Black Fabric Braided Cable 3 Core Twisted

FIXING BRACKET: MLROSE39 | Polished Chrome

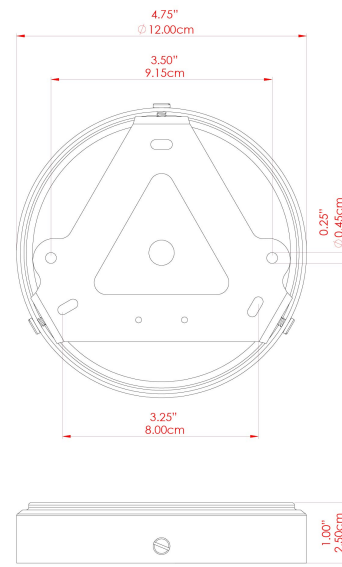

Product Notes:
 1) Bulbs not included. 2) Dimensions do not include bulbs. 3) All products are individually made-to-order and therefore may differ slightly within manufacturing tolerances. 4) Cable / chain can be shortened during installation. Longer cable / chain lengths available on request. 5) Additional color finishes may be available on request. 6) Twisted cable is not available for UL wired products. Round cable in black or brown only is supplied instead. 7) Refer to our website for a full list of terms and conditions.



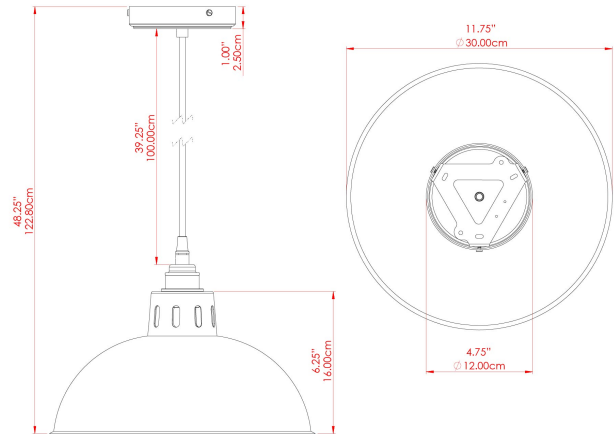

MATERIAL	Brass Aluminium
HEIGHT	8.75"
WIDTH DIAMETER	11.75"
LENGTH PROJECTION	n/a
WEIGHT	0.46 kg 1 lbs
LAMPHOLDER	E26
MAX WATTAGE	60W
VOLTAGE	110/120v
ENVIRONMENTAL RATING	Dry Location (IP20)
CLASS PROTECTION	Class I
SHADE	-
FLEX BAR CHAIN LENGTH	40"
CABLE TYPE	MLCA020 Black Fabric Braided Cable 3 Core Twisted

FIXING BRACKET: MLROSE39 | Polished Chrome

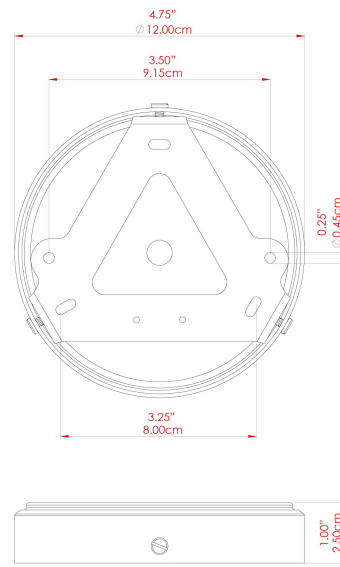

Product Notes:
 1) Bulbs not included. 2) Dimensions do not include bulbs. 3) All products are individually made-to-order and therefore may differ slightly within manufacturing tolerances. 4) Cable / chain can be shortened during installation. Longer cable / chain lengths available on request. 5) Additional color finishes may be available on request. 6) Twisted cable is not available for UL wired products. Round cable in black or brown only is supplied instead. 7) Refer to our website for a full list of terms and conditions.

