

# STANLEY 20CM Pendant

## MLP375ANTBRS Antique Brass

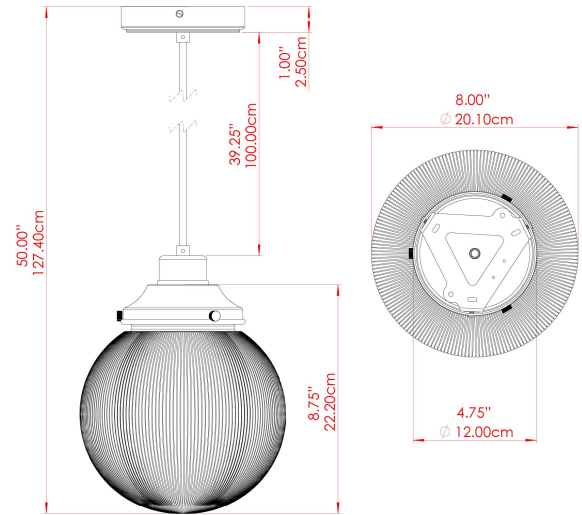

MATERIAL	Brass   Glass
HEIGHT	10.25"
WIDTH   DIAMETER	7.75"
LENGTH   PROJECTION	n/a
WEIGHT	0.71 kg   1.5 lbs
LAMPHOLDER	E26
MAX WATTAGE	40W
VOLTAGE	110/120v
ENVIRONMENTAL RATING	Dry Location (IP20)
CLASS PROTECTION	Class I
SHADE	GL155
FLEX   BAR   CHAIN LENGTH	40"
CABLE TYPE	MLCA002   Brown Fabric Braided Cable   2 Core Twisted

### FIXING BRACKET: MLROSE39 | Antique Brass

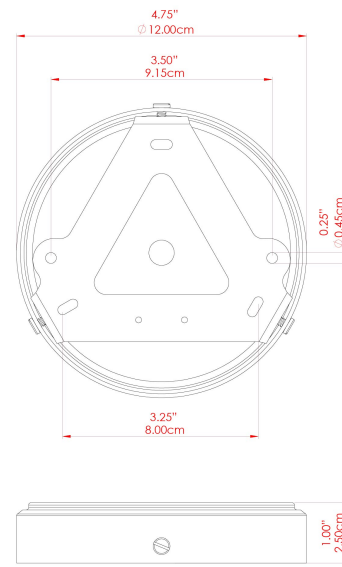

Product Notes:  
 1) Bulbs not included. 2) Dimensions do not include bulbs. 3) All products are individually made-to-order and therefore may differ slightly within manufacturing tolerances. 4) Cable / chain can be shortened during installation. Longer cable / chain lengths available on request. 5) Additional color finishes may be available on request. 6) Twisted cable is not available for UL wired products. Round cable in black or brown only is supplied instead. 7) Refer to our website for a full list of terms and conditions.



# STANLEY 20CM Pendant

# MLP375ANTSLV Antique Silver

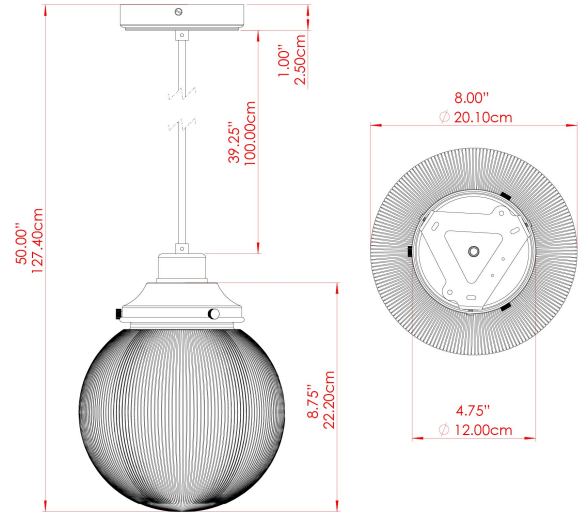

MATERIAL	Brass   Glass
HEIGHT	8.75"
WIDTH   DIAMETER	7.75"
LENGTH   PROJECTION	n/a
WEIGHT	0.71 kg   1.5 lbs
LAMPHOLDER	E26
MAX WATTAGE	40W
VOLTAGE	110/120v
ENVIRONMENTAL RATING	Dry Location (IP20)
CLASS PROTECTION	Class I
SHADE	GL155
FLEX   BAR   CHAIN LENGTH	40"
CABLE TYPE	MLCA001   Black Fabric Braided Cable   2 Core Twisted

## FIXING BRACKET: MLROSE39 | Antique Silver

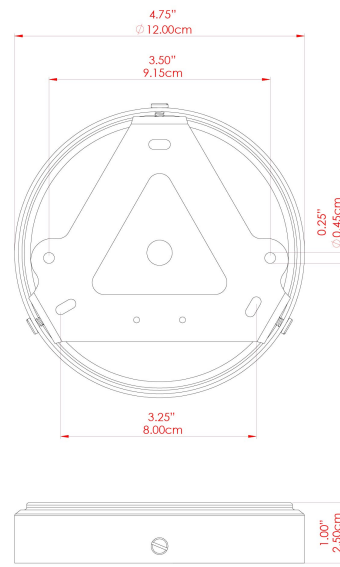

Product Notes:  
 1) Bulbs not included. 2) Dimensions do not include bulbs. 3) All products are individually made-to-order and therefore may differ slightly within manufacturing tolerances. 4) Cable / chain can be shortened during installation. Longer cable / chain lengths available on request. 5) Additional color finishes may be available on request. 6) Twisted cable is not available for UL wired products. Round cable in black or brown only is supplied instead. 7) Refer to our website for a full list of terms and conditions.





## STANLEY 20CM Pendant

MLP375POLBRS Polished Brass

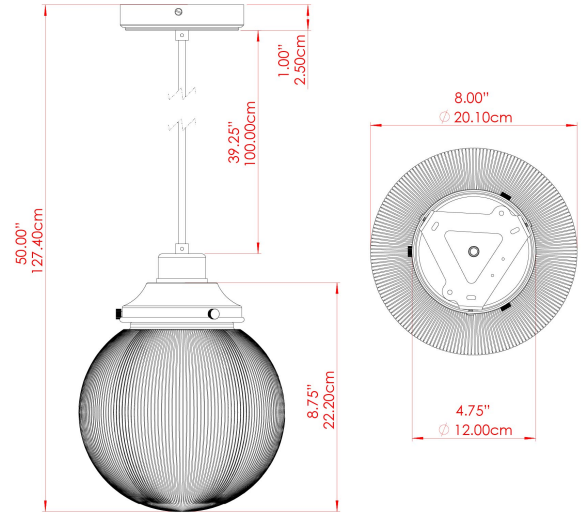

MATERIAL	Brass   Glass
HEIGHT	8.75"
WIDTH   DIAMETER	7.75"
LENGTH   PROJECTION	n/a
WEIGHT	0.71 kg   1.5 lbs
LAMPHOLDER	E26
MAX WATTAGE	40W
VOLTAGE	110/120v
ENVIRONMENTAL RATING	Dry Location (IP20)
CLASS PROTECTION	Class I
SHADE	GL155
FLEX   BAR   CHAIN LENGTH	40"
CABLE TYPE	MLCA001   Black Fabric Braided Cable   2 Core Twisted

FIXING BRACKET: MLROSE39 | Polished Brass

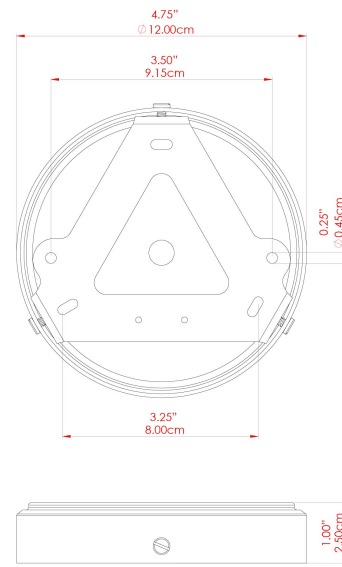

Product Notes:  
1) Bulbs not included. 2) Dimensions do not include bulbs. 3) All products are individually made-to-order and therefore may differ slightly within manufacturing tolerances. 4) Cable / chain can be shortened during installation. Longer cable / chain lengths available on request. 5) Additional color finishes may be available on request. 6) Twisted cable is not available for UL wired products. Round cable in black or brown only is supplied instead. 7) Refer to our website for a full list of terms and conditions.





# STANLEY 20CM Pendant

MLP375POLCHR Polished Chrome

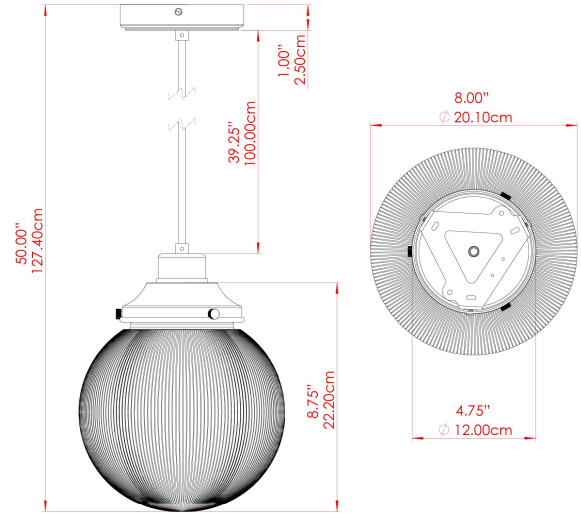

MATERIAL	Brass   Glass
HEIGHT	8.75"
WIDTH   DIAMETER	7.75"
LENGTH   PROJECTION	n/a
WEIGHT	0.71 kg   1.5 lbs
LAMPHOLDER	E26
MAX WATTAGE	40W
VOLTAGE	110/120v
ENVIRONMENTAL RATING	Dry Location (IP20)
CLASS PROTECTION	Class I
SHADE	GL155
FLEX   BAR   CHAIN LENGTH	40"
CABLE TYPE	MLCA001   Black Fabric Braided Cable   2 Core Twisted

## FIXING BRACKET: MLROSE39 | Polished Chrome

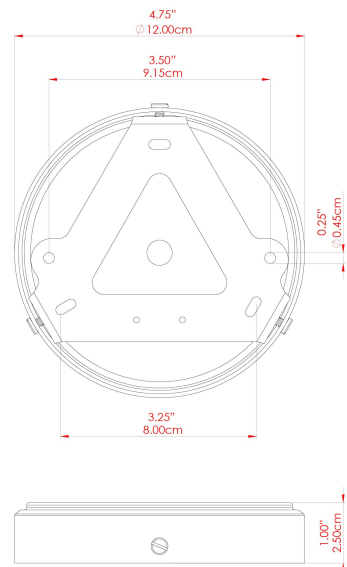

Product Notes:  
 1) Bulbs not included. 2) Dimensions do not include bulbs. 3) All products are individually made-to-order and therefore may differ slightly within manufacturing tolerances. 4) Cable / chain can be shortened during installation. Longer cable / chain lengths available on request. 5) Additional color finishes may be available on request. 6) Twisted cable is not available for UL wired products. Round cable in black or brown only is supplied instead. 7) Refer to our website for a full list of terms and conditions.





# STANLEY 20CM Pendant

MLP375SATBRS Satin Brass

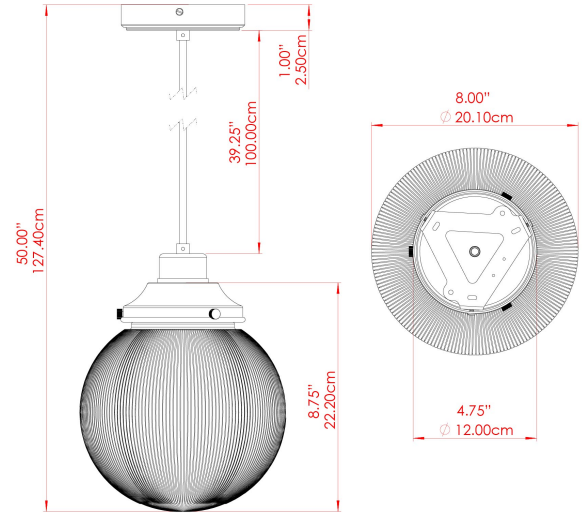

MATERIAL	Brass   Glass
HEIGHT	8.75"
WIDTH   DIAMETER	7.75"
LENGTH   PROJECTION	n/a
WEIGHT	0.71 kg   1.5 lbs
LAMPHOLDER	E26
MAX WATTAGE	40W
VOLTAGE	110/120v
ENVIRONMENTAL RATING	Dry Location (IP20)
CLASS PROTECTION	Class I
SHADE	GL155
FLEX   BAR   CHAIN LENGTH	40"
CABLE TYPE	MLCA001   Black Fabric Braided Cable   2 Core Twisted

## FIXING BRACKET: MLROSE39 | Satin Brass

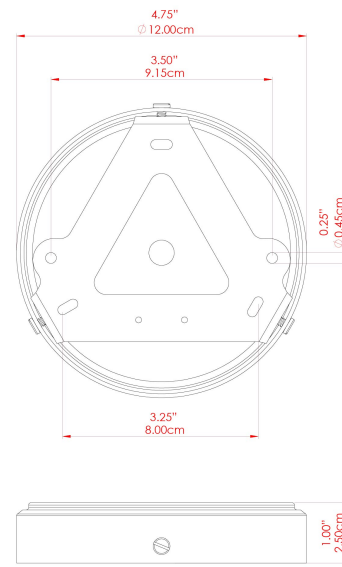

Product Notes:  
 1) Bulbs not included. 2) Dimensions do not include bulbs. 3) All products are individually made-to-order and therefore may differ slightly within manufacturing tolerances. 4) Cable / chain can be shortened during installation. Longer cable / chain lengths available on request. 5) Additional color finishes may be available on request. 6) Twisted cable is not available for UL wired products. Round cable in black or brown only is supplied instead. 7) Refer to our website for a full list of terms and conditions.





# STANLEY 20CM Pendant

MLP375SATCHR Satin Chrome

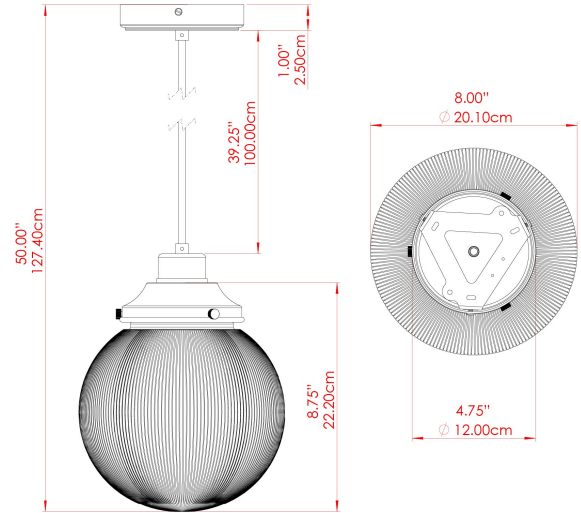

MATERIAL	Brass   Glass
HEIGHT	8.75"
WIDTH   DIAMETER	7.75"
LENGTH   PROJECTION	n/a
WEIGHT	0.71 kg   1.5 lbs
LAMPHOLDER	E26
MAX WATTAGE	40W
VOLTAGE	110/120v
ENVIRONMENTAL RATING	Dry Location (IP20)
CLASS PROTECTION	Class I
SHADE	GL155
FLEX   BAR   CHAIN LENGTH	40"
CABLE TYPE	MLCA001   Black Fabric Braided Cable   2 Core Twisted

### FIXING BRACKET: MLROSE39 | Satin Chrome

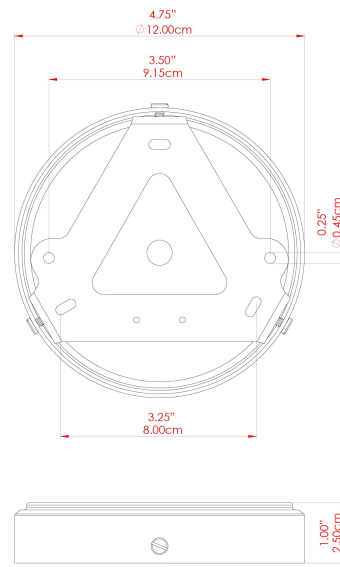

Product Notes:  
 1) Bulbs not included. 2) Dimensions do not include bulbs. 3) All products are individually made-to-order and therefore may differ slightly within manufacturing tolerances. 4) Cable / chain can be shortened during installation. Longer cable / chain lengths available on request. 5) Additional color finishes may be available on request. 6) Twisted cable is not available for UL wired products. Round cable in black or brown only is supplied instead. 7) Refer to our website for a full list of terms and conditions.

