

# RIO Pendant

## MLP507ANTBRSPCMAP Antique Brass

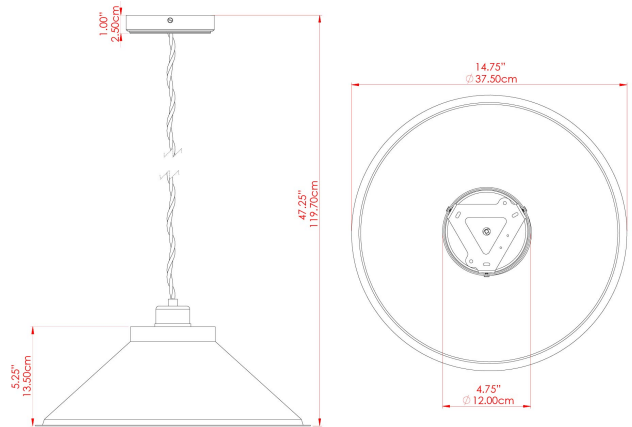

|                           |   |
|---------------------------|---|
| MATERIAL                  | Brass   Aluminium                                     |
| HEIGHT                    | 5.25"   |
| WIDTH   DIAMETER          | 14.75"  |
| LENGTH   PROJECTION       | n/a   |
| WEIGHT                    | 0.8 kg   1.8 lbs                                      |
| LAMPHOLDER                | E26   |
| MAX WATTAGE               | 40W   |
| VOLTAGE                   | 110/120v  |
| ENVIRONMENTAL RATING      | Dry Location (IP20)                                   |
| CLASS PROTECTION          | Class I   |
| SHADE                     | -   |
| FLEX   BAR   CHAIN LENGTH | 40"   |
| CABLE TYPE                | MLCA003   Ivory Fabric Braided Cable   2 Core Twisted |

### FIXING BRACKET: MLROSE39 | Matt Antique Pink

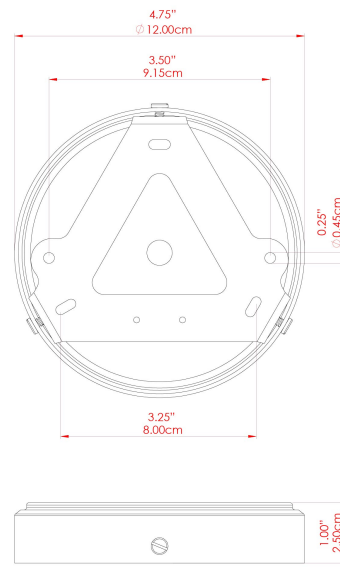

Product Notes:  
 1) Bulbs not included. 2) Dimensions do not include bulbs. 3) All products are individually made-to-order and therefore may differ slightly within manufacturing tolerances. 4) Cable / chain can be shortened during installation. Longer cable / chain lengths available on request. 5) Additional color finishes may be available on request. 6) Twisted cable is not available for UL wired products. Round cable in black or brown only is supplied instead. 7) Refer to our website for a full list of terms and conditions.



# RIO Pendant

## MLP507ANTBRSPCMBK Antique Brass

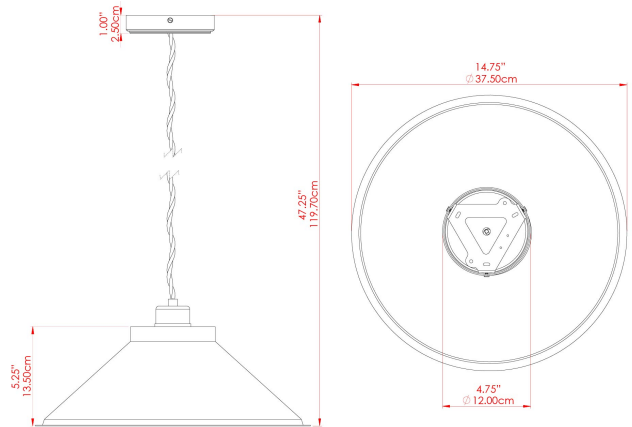

|                           |   |
|---------------------------|---|
| MATERIAL                  | Brass   Aluminium                                     |
| HEIGHT                    | 5.25"   |
| WIDTH   DIAMETER          | 14.75"  |
| LENGTH   PROJECTION       | n/a   |
| WEIGHT                    | 0.8 kg   1.8 lbs                                      |
| LAMPHOLDER                | E26   |
| MAX WATTAGE               | 40W   |
| VOLTAGE                   | 110/120v  |
| ENVIRONMENTAL RATING      | Dry Location (IP20)                                   |
| CLASS PROTECTION          | Class I   |
| SHADE                     | -   |
| FLEX   BAR   CHAIN LENGTH | 40"   |
| CABLE TYPE                | MLCA001   Black Fabric Braided Cable   2 Core Twisted |

### FIXING BRACKET: MLROSE39 | Matt Black

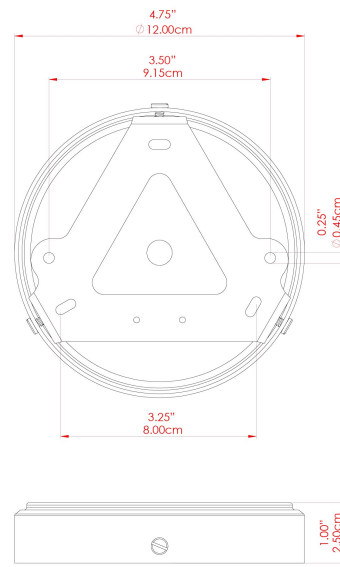

Product Notes:  
 1) Bulbs not included. 2) Dimensions do not include bulbs. 3) All products are individually made-to-order and therefore may differ slightly within manufacturing tolerances. 4) Cable / chain can be shortened during installation. Longer cable / chain lengths available on request. 5) Additional color finishes may be available on request. 6) Twisted cable is not available for UL wired products. Round cable in black or brown only is supplied instead. 7) Refer to our website for a full list of terms and conditions.



# RIO Pendant

## MLP507ANTBRSPCMMT Antique Brass

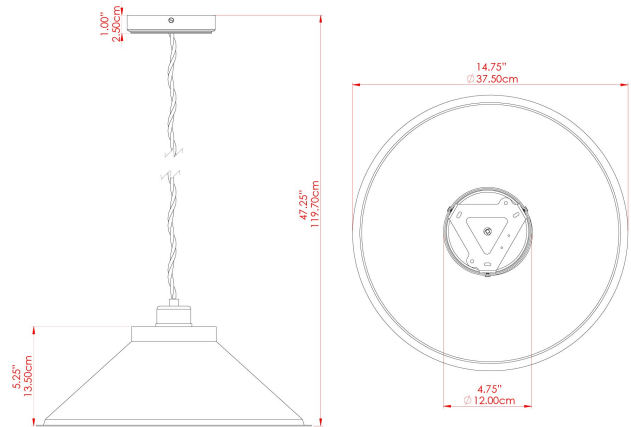

|                           |   |
|---------------------------|---|
| MATERIAL                  | Brass   Aluminium                                     |
| HEIGHT                    | 5.25"   |
| WIDTH   DIAMETER          | 14.75"  |
| LENGTH   PROJECTION       | n/a   |
| WEIGHT                    | 0.8 kg   1.8 lbs                                      |
| LAMPHOLDER                | E26   |
| MAX WATTAGE               | 40W   |
| VOLTAGE                   | 110/120v  |
| ENVIRONMENTAL RATING      | Dry Location (IP20)                                   |
| CLASS PROTECTION          | Class I   |
| SHADE                     | -   |
| FLEX   BAR   CHAIN LENGTH | 40"   |
| CABLE TYPE                | MLCA003   Ivory Fabric Braided Cable   2 Core Twisted |

### FIXING BRACKET: MLROSE39 | Matt Mint Turquoise

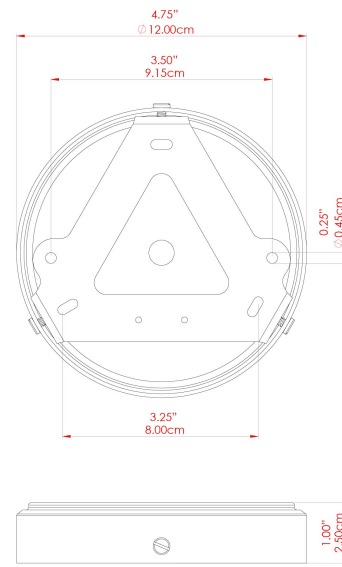

**Product Notes:**

1) Bulbs not included. 2) Dimensions do not include bulbs. 3) All products are individually made-to-order and therefore may differ slightly within manufacturing tolerances. 4) Cable / chain can be shortened during installation. Longer cable / chain lengths available on request. 5) Additional color finishes may be available on request. 6) Twisted cable is not available for UL wired products. Round cable in black or brown only is supplied instead. 7) Refer to our website for a full list of terms and conditions.



# RIO Pendant

## MLP507ANTBRSPCORG Antique Brass

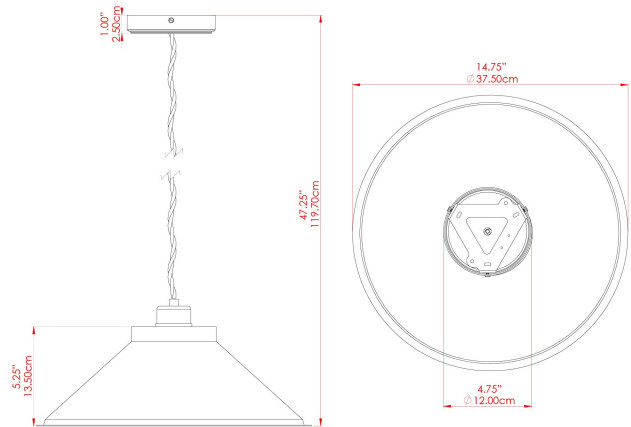

|                           |  |
|---------------------------|--|
| MATERIAL                  | Brass   Aluminium                                      |
| HEIGHT                    | 5.25"  |
| WIDTH   DIAMETER          | 14.75"   |
| LENGTH   PROJECTION       | n/a  |
| WEIGHT                    | 0.8 kg   1.8 lbs                                       |
| LAMPHOLDER                | E26  |
| MAX WATTAGE               | 40W  |
| VOLTAGE                   | 110/120v   |
| ENVIRONMENTAL RATING      | Dry Location (IP20)                                    |
| CLASS PROTECTION          | Class I  |
| SHADE                     | -  |
| FLEX   BAR   CHAIN LENGTH | 40"  |
| CABLE TYPE                | MLCA042   Orange Fabric Braided Cable   2 Core Twisted |

### FIXING BRACKET: MLROSE39 | Orange

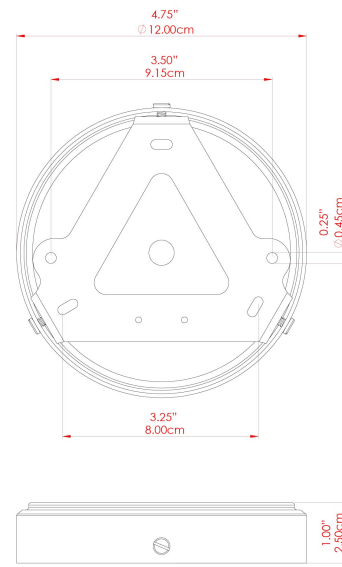

Product Notes:  
 1) Bulbs not included. 2) Dimensions do not include bulbs. 3) All products are individually made-to-order and therefore may differ slightly within manufacturing tolerances. 4) Cable / chain can be shortened during installation. Longer cable / chain lengths available on request. 5) Additional color finishes may be available on request. 6) Twisted cable is not available for UL wired products. Round cable in black or brown only is supplied instead. 7) Refer to our website for a full list of terms and conditions.



# RIO Pendant

## MLP507ANTBRSPCRGR Antique Brass

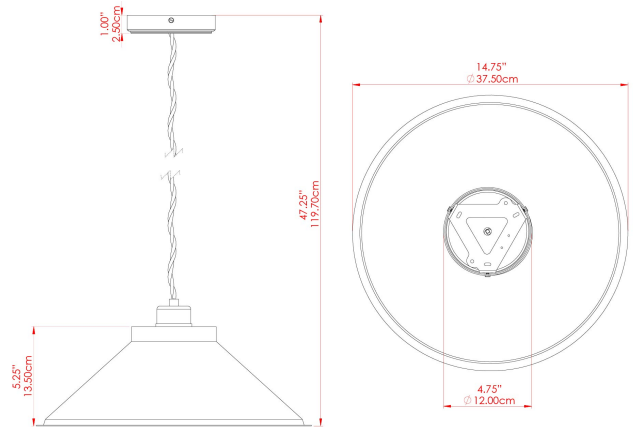

|                           |   |
|---------------------------|---|
| MATERIAL                  | Brass   Aluminium                                     |
| HEIGHT                    | 5.25"   |
| WIDTH   DIAMETER          | 14.75"  |
| LENGTH   PROJECTION       | n/a   |
| WEIGHT                    | 0.8 kg   1.8 lbs                                      |
| LAMPHOLDER                | E26   |
| MAX WATTAGE               | 40W   |
| VOLTAGE                   | 110/120v  |
| ENVIRONMENTAL RATING      | Dry Location (IP20)                                   |
| CLASS PROTECTION          | Class I   |
| SHADE                     | -   |
| FLEX   BAR   CHAIN LENGTH | 40"   |
| CABLE TYPE                | MLCA001   Black Fabric Braided Cable   2 Core Twisted |

### FIXING BRACKET: MLROSE39 | Racing Green

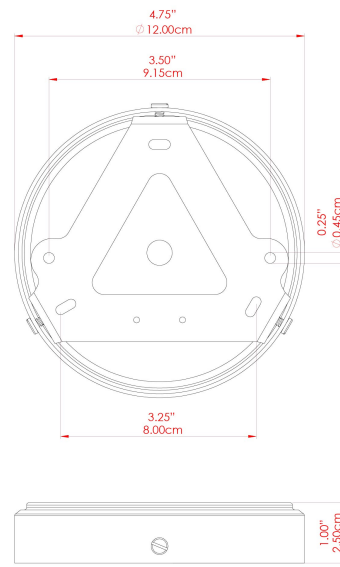

Product Notes:  
 1) Bulbs not included. 2) Dimensions do not include bulbs. 3) All products are individually made-to-order and therefore may differ slightly within manufacturing tolerances. 4) Cable / chain can be shortened during installation. Longer cable / chain lengths available on request. 5) Additional color finishes may be available on request. 6) Twisted cable is not available for UL wired products. Round cable in black or brown only is supplied instead. 7) Refer to our website for a full list of terms and conditions.



# RIO Pendant

## MLP507ANTBRSPCRED Antique Brass

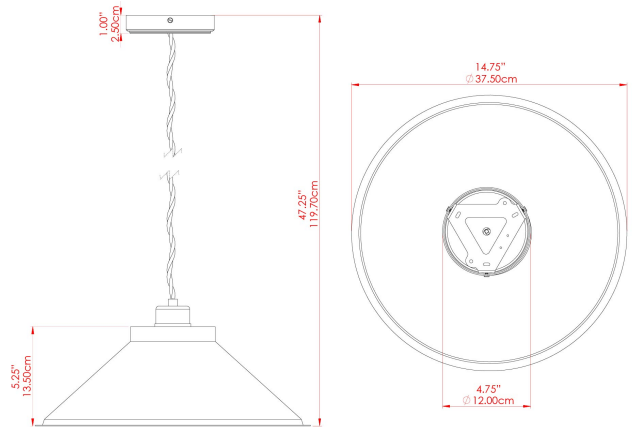

|                           |   |
|---------------------------|---|
| MATERIAL                  | Brass   Aluminium                                   |
| HEIGHT                    | 5.25"   |
| WIDTH   DIAMETER          | 14.75"  |
| LENGTH   PROJECTION       | n/a   |
| WEIGHT                    | 0.8 kg   1.8 lbs                                    |
| LAMPHOLDER                | E26   |
| MAX WATTAGE               | 40W   |
| VOLTAGE                   | 110/120v  |
| ENVIRONMENTAL RATING      | Dry Location (IP20)                                 |
| CLASS PROTECTION          | Class I   |
| SHADE                     | -   |
| FLEX   BAR   CHAIN LENGTH | 40"   |
| CABLE TYPE                | MLCA034   Red Fabric Braided Cable   2 Core Twisted |

### FIXING BRACKET: MLROSE39 | Red

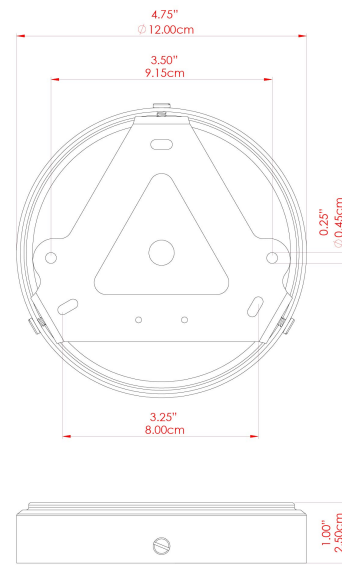

Product Notes:  
 1) Bulbs not included. 2) Dimensions do not include bulbs. 3) All products are individually made-to-order and therefore may differ slightly within manufacturing tolerances. 4) Cable / chain can be shortened during installation. Longer cable / chain lengths available on request. 5) Additional color finishes may be available on request. 6) Twisted cable is not available for UL wired products. Round cable in black or brown only is supplied instead. 7) Refer to our website for a full list of terms and conditions.



# RIO Pendant

## MLP507ANTBRSPCGRN Antique Brass

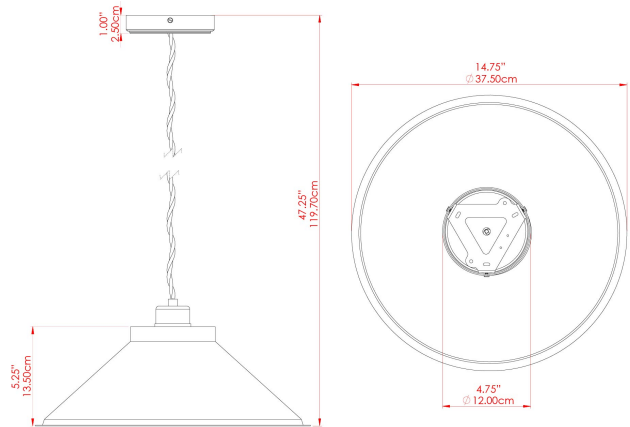

|                           |  |
|---------------------------|--|
| MATERIAL                  | Brass   Aluminium  |
| HEIGHT                    | 5.25"  |
| WIDTH   DIAMETER          | 14.75"   |
| LENGTH   PROJECTION       | n/a  |
| WEIGHT                    | 0.8 kg   1.8 lbs   |
| LAMPHOLDER                | E26  |
| MAX WATTAGE               | 40W  |
| VOLTAGE                   | 110/120v   |
| ENVIRONMENTAL RATING      | Dry Location (IP20)  |
| CLASS PROTECTION          | Class I  |
| SHADE                     | -  |
| FLEX   BAR   CHAIN LENGTH | 40"  |
| CABLE TYPE                | MLCA041   Sage Green Fabric Braided Cable   2 Core Twisted |

### FIXING BRACKET: MLROSE39 | Sage Green

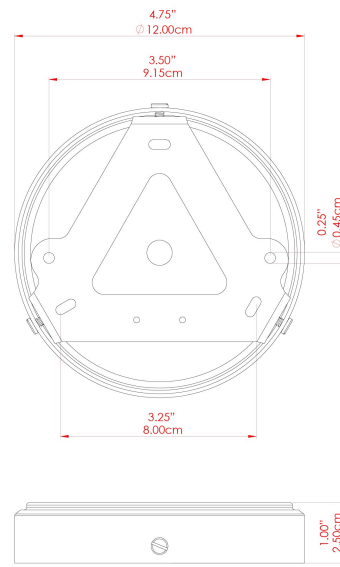

Product Notes:  
 1) Bulbs not included. 2) Dimensions do not include bulbs. 3) All products are individually made-to-order and therefore may differ slightly within manufacturing tolerances. 4) Cable / chain can be shortened during installation. Longer cable / chain lengths available on request. 5) Additional color finishes may be available on request. 6) Twisted cable is not available for UL wired products. Round cable in black or brown only is supplied instead. 7) Refer to our website for a full list of terms and conditions.



# RIO Pendant

## MLP507ANTBRSPCCRM Antique Brass

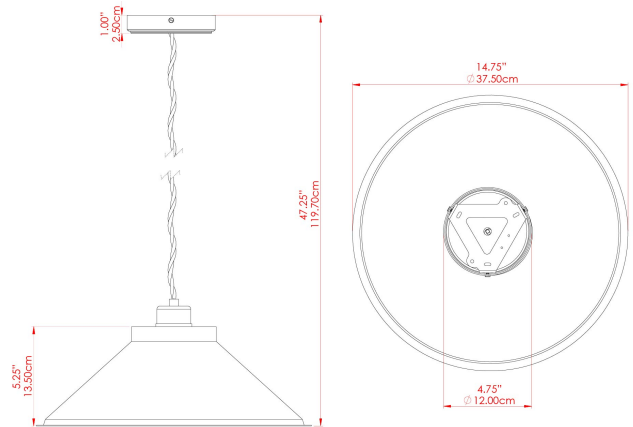

|                           |   |
|---------------------------|---|
| MATERIAL                  | Brass   Aluminium                                     |
| HEIGHT                    | 5.25"   |
| WIDTH   DIAMETER          | 14.75"  |
| LENGTH   PROJECTION       | n/a   |
| WEIGHT                    | 0.8 kg   1.8 lbs                                      |
| LAMPHOLDER                | E26   |
| MAX WATTAGE               | 40W   |
| VOLTAGE                   | 110/120v  |
| ENVIRONMENTAL RATING      | Dry Location (IP20)                                   |
| CLASS PROTECTION          | Class I   |
| SHADE                     | -   |
| FLEX   BAR   CHAIN LENGTH | 40"   |
| CABLE TYPE                | MLCA003   Ivory Fabric Braided Cable   2 Core Twisted |

### FIXING BRACKET: MLROSE39 | Matt Vanilla Cream

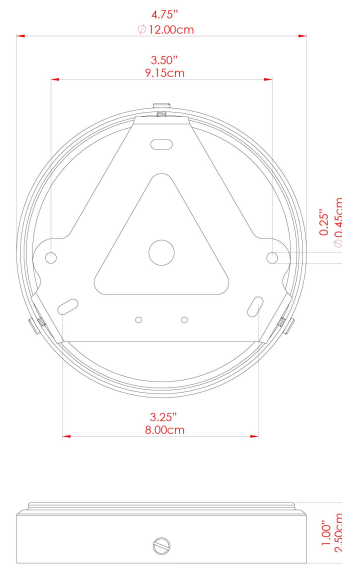

Product Notes:  
 1) Bulbs not included. 2) Dimensions do not include bulbs. 3) All products are individually made-to-order and therefore may differ slightly within manufacturing tolerances. 4) Cable / chain can be shortened during installation. Longer cable / chain lengths available on request. 5) Additional color finishes may be available on request. 6) Twisted cable is not available for UL wired products. Round cable in black or brown only is supplied instead. 7) Refer to our website for a full list of terms and conditions.



# RIO Pendant

## MLP507ANTBRSPCYLW Antique Brass

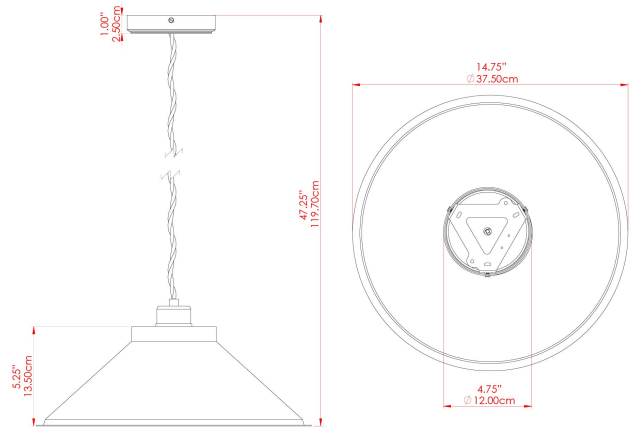

|                           |   |
|---------------------------|---|
| MATERIAL                  | Brass   Aluminium                                     |
| HEIGHT                    | 5.25"   |
| WIDTH   DIAMETER          | 14.75"  |
| LENGTH   PROJECTION       | n/a   |
| WEIGHT                    | 0.8 kg   1.8 lbs                                      |
| LAMPHOLDER                | E26   |
| MAX WATTAGE               | 40W   |
| VOLTAGE                   | 110/120v  |
| ENVIRONMENTAL RATING      | Dry Location (IP20)                                   |
| CLASS PROTECTION          | Class I   |
| SHADE                     | -   |
| FLEX   BAR   CHAIN LENGTH | 40"   |
| CABLE TYPE                | MLCA003   Ivory Fabric Braided Cable   2 Core Twisted |

### FIXING BRACKET: MLROSE39 | Yellow

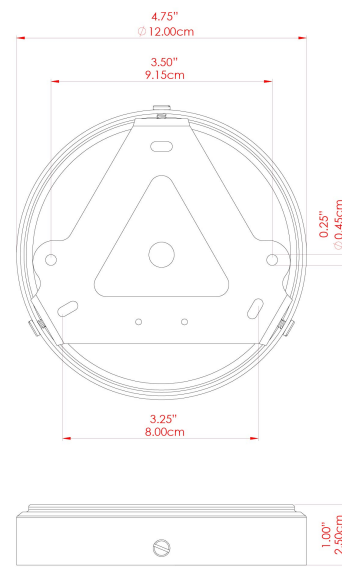

Product Notes:  
 1) Bulbs not included. 2) Dimensions do not include bulbs. 3) All products are individually made-to-order and therefore may differ slightly within manufacturing tolerances. 4) Cable / chain can be shortened during installation. Longer cable / chain lengths available on request. 5) Additional color finishes may be available on request. 6) Twisted cable is not available for UL wired products. Round cable in black or brown only is supplied instead. 7) Refer to our website for a full list of terms and conditions.



# RIO Pendant

## MLP507ANTBRSPCMSB Antique Brass

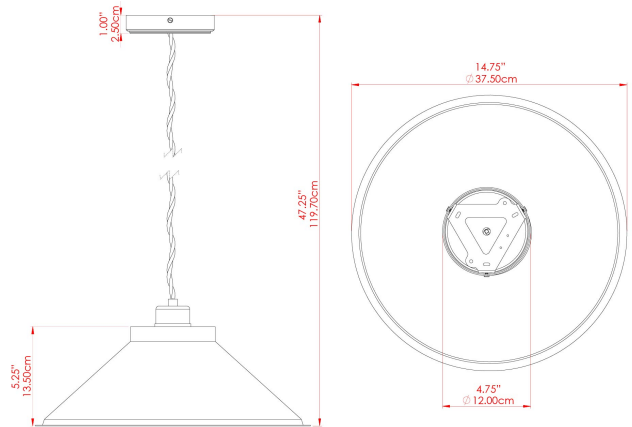

|                           |   |
|---------------------------|---|
| MATERIAL                  | Brass   Aluminium   |
| HEIGHT                    | 5.25"   |
| WIDTH   DIAMETER          | 14.75"  |
| LENGTH   PROJECTION       | n/a   |
| WEIGHT                    | 0.8 kg   1.8 lbs  |
| LAMPHOLDER                | E26   |
| MAX WATTAGE               | 40W   |
| VOLTAGE                   | 110/120v  |
| ENVIRONMENTAL RATING      | Dry Location (IP20)   |
| CLASS PROTECTION          | Class I   |
| SHADE                     | -   |
| FLEX   BAR   CHAIN LENGTH | 40"   |
| CABLE TYPE                | MLCA040   Electric Blue Fabric Braided Cable   2 Core Twisted |

### FIXING BRACKET: MLROSE39 | Matt Sapphire Blue

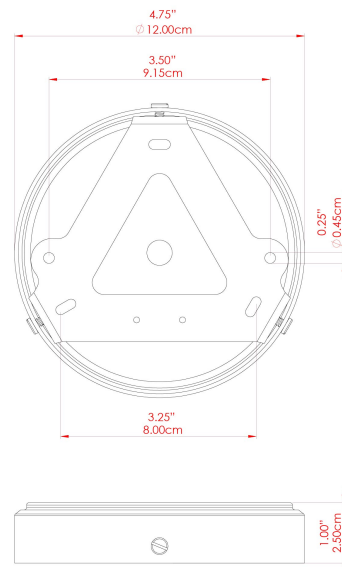

Product Notes:  
 1) Bulbs not included. 2) Dimensions do not include bulbs. 3) All products are individually made-to-order and therefore may differ slightly within manufacturing tolerances. 4) Cable / chain can be shortened during installation. Longer cable / chain lengths available on request. 5) Additional color finishes may be available on request. 6) Twisted cable is not available for UL wired products. Round cable in black or brown only is supplied instead. 7) Refer to our website for a full list of terms and conditions.

