

| | |
|---------------------------|---------------------|
| MATERIAL | Brass Glass |
| HEIGHT | 5.5" |
| WIDTH DIAMETER | 4.25" |
| LENGTH PROJECTION | 5.5" |
| WEIGHT | 0.95 kg 2 lbs |
| LAMPHOLDER | GU10 |
| MAX WATTAGE | 6.5W |
| VOLTAGE | 110/120v |
| ENVIRONMENTAL RATING | Wet Location (IP64) |
| CLASS PROTECTION | Class I |
| SHADE | - |
| FLEX BAR CHAIN LENGTH | n/a |
| CABLE TYPE | |

FIXING BRACKET: -



Product Notes:
 1) Bulbs not included. 2) Dimensions do not include bulbs. 3) All products are individually made-to-order and therefore may differ slightly within manufacturing tolerances. 4) Cable / chain can be shortened during installation. Longer cable / chain lengths available on request. 5) Additional color finishes may be available on request. 6) Twisted cable is not available for UL wired products. Round cable in black or brown only is supplied instead. 7) Refer to our website for a full list of terms and conditions.



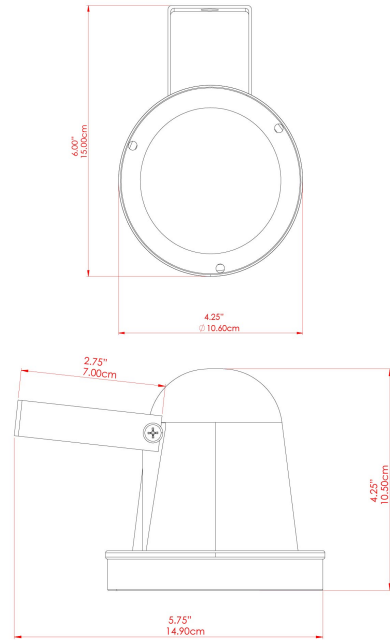

| | |
|---------------------------|---------------------|
| MATERIAL | Brass Glass |
| HEIGHT | 5.5" |
| WIDTH DIAMETER | 4.25" |
| LENGTH PROJECTION | 5.5" |
| WEIGHT | 0.95 kg 2 lbs |
| LAMPHOLDER | GU10 |
| MAX WATTAGE | 6.5W |
| VOLTAGE | 110/120v |
| ENVIRONMENTAL RATING | Wet Location (IP64) |
| CLASS PROTECTION | Class I |
| SHADE | - |
| FLEX BAR CHAIN LENGTH | n/a |
| CABLE TYPE | |

FIXING BRACKET: -



Product Notes:
 1) Bulbs not included. 2) Dimensions do not include bulbs. 3) All products are individually made-to-order and therefore may differ slightly within manufacturing tolerances. 4) Cable / chain can be shortened during installation. Longer cable / chain lengths available on request. 5) Additional color finishes may be available on request. 6) Twisted cable is not available for UL wired products. Round cable in black or brown only is supplied instead. 7) Refer to our website for a full list of terms and conditions.



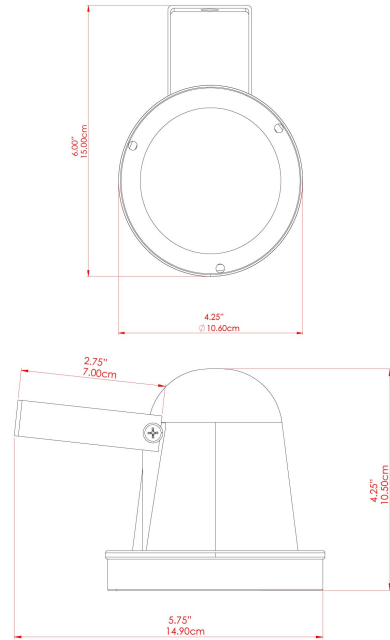

| | |
|---------------------------|---------------------|
| MATERIAL | Brass Glass |
| HEIGHT | 5.5" |
| WIDTH DIAMETER | 4.25" |
| LENGTH PROJECTION | 5.5" |
| WEIGHT | 0.95 kg 2 lbs |
| LAMPHOLDER | GU10 |
| MAX WATTAGE | 6.5W |
| VOLTAGE | 110/120v |
| ENVIRONMENTAL RATING | Wet Location (IP64) |
| CLASS PROTECTION | Class I |
| SHADE | - |
| FLEX BAR CHAIN LENGTH | n/a |
| CABLE TYPE | |

FIXING BRACKET: -



WWW.MULLANLIGHTING.COM

Product Notes:

1) Bulbs not included. 2) Dimensions do not include bulbs. 3) All products are individually made-to-order and therefore may differ slightly within manufacturing tolerances. 4) Cable / chain can be shortened during installation. Longer cable / chain lengths available on request. 5) Additional color finishes may be available on request. 6) Twisted cable is not available for UL wired products. Round cable in black or brown only is supplied instead. 7) Refer to our website for a full list of terms and conditions.

