

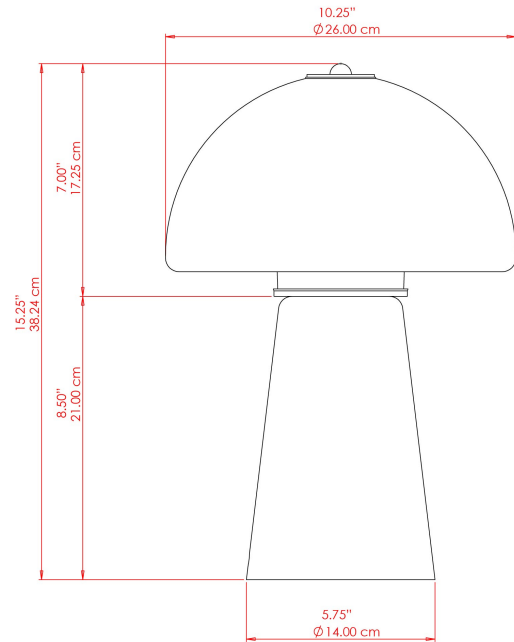

CHAMPIGNON Ceramic Table Lamp

MLCMTL051ANTBRS Antique Brass



| | | |
|---------------------------|---|-------------------|
| MATERIAL | Brass Ceramic Steel Glass | FIXING BRACKET: - |
| HEIGHT | 15" | |
| WIDTH DIAMETER | 10.25" | |
| LENGTH PROJECTION | n/a | |
| WEIGHT | 3.3 kg 7.3 lbs | |
| LAMPHOLDER | E26 | |
| MAX WATTAGE | 40W | |
| VOLTAGE | 110/120v | |
| ENVIRONMENTAL RATING | Dry Location (IP20) | |
| CLASS PROTECTION | Class I | |
| SHADE | GL203 | |
| FLEX BAR CHAIN LENGTH | n/a | |
| CABLE TYPE | MLCA029 Black Fabric Braided Cable 3 Core Round | |



Product Notes:

1) Bulbs not included. 2) Dimensions do not include bulbs. 3) All products are individually made-to-order and therefore may differ slightly within manufacturing tolerances. 4) Cable / chain can be shortened during installation. Longer cable / chain lengths available on request. 5) Additional color finishes may be available on request. 6) Twisted cable is not available for UL wired products. Round cable in black or brown only is supplied instead. 7) Refer to our website for a full list of terms and conditions.





CHAMPIGNON Ceramic Table Lamp

MLCMTL051ANTSLV Antique Silver

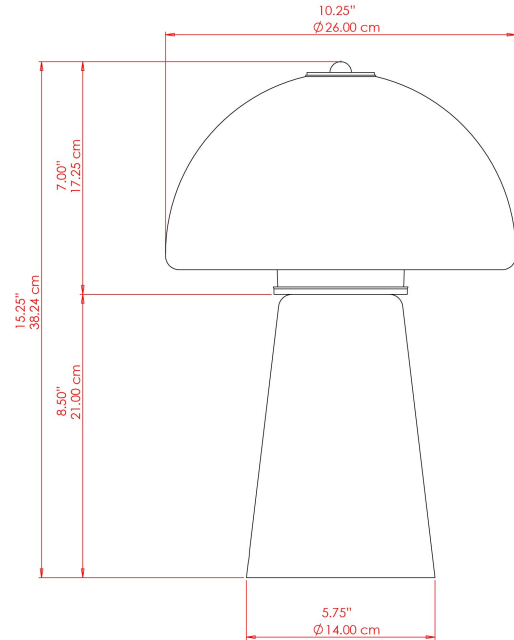

| | | |
|---------------------------|---|-------------------|
| MATERIAL | Brass Ceramic Steel Glass | FIXING BRACKET: - |
| HEIGHT | 15" | |
| WIDTH DIAMETER | 10.25" | |
| LENGTH PROJECTION | n/a | |
| WEIGHT | 3.3 kg 7.3 lbs | |
| LAMPHOLDER | E26 | |
| MAX WATTAGE | 40W | |
| VOLTAGE | 110/120v | |
| ENVIRONMENTAL RATING | Dry Location (IP20) | |
| CLASS PROTECTION | Class I | |
| SHADE | GL203 | |
| FLEX BAR CHAIN LENGTH | n/a | |
| CABLE TYPE | MLCA029 Black Fabric Braided Cable 3 Core Round | |



Product Notes:
1) Bulbs not included. 2) Dimensions do not include bulbs. 3) All products are individually made-to-order and therefore may differ slightly within manufacturing tolerances. 4) Cable / chain can be shortened during installation. Longer cable / chain lengths available on request. 5) Additional color finishes may be available on request. 6) Twisted cable is not available for UL wired products. Round cable in black or brown only is supplied instead. 7) Refer to our website for a full list of terms and conditions.





CHAMPIGNON Ceramic Table Lamp MLCMTL051POLBRS Polished Brass

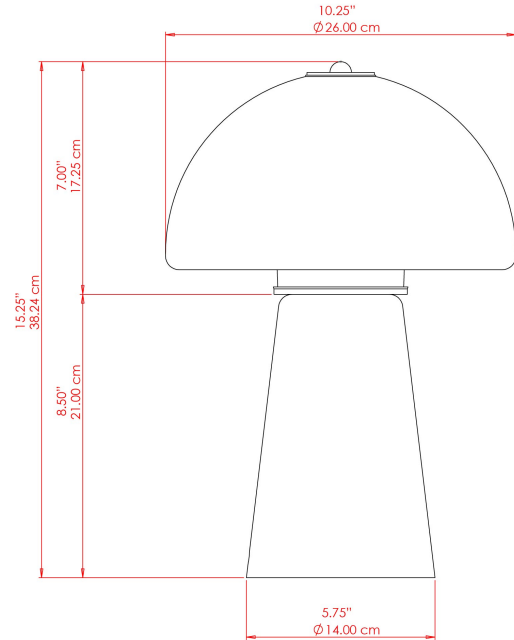

| | | |
|---------------------------|---|-------------------|
| MATERIAL | Brass Ceramic Steel Glass | FIXING BRACKET: - |
| HEIGHT | 15" | |
| WIDTH DIAMETER | 10.25" | |
| LENGTH PROJECTION | n/a | |
| WEIGHT | 3.3 kg 7.3 lbs | |
| LAMPHOLDER | E26 | |
| MAX WATTAGE | 40W | |
| VOLTAGE | 110/120v | |
| ENVIRONMENTAL RATING | Dry Location (IP20) | |
| CLASS PROTECTION | Class I | |
| SHADE | GL203 | |
| FLEX BAR CHAIN LENGTH | n/a | |
| CABLE TYPE | MLCA029 Black Fabric Braided Cable 3 Core Round | |



Product Notes:
1) Bulbs not included. 2) Dimensions do not include bulbs. 3) All products are individually made-to-order and therefore may differ slightly within manufacturing tolerances. 4) Cable / chain can be shortened during installation. Longer cable / chain lengths available on request. 5) Additional color finishes may be available on request. 6) Twisted cable is not available for UL wired products. Round cable in black or brown only is supplied instead. 7) Refer to our website for a full list of terms and conditions.





CHAMPIGNON Ceramic Table Lamp

MLCMTL051SATBRS Satin Brass

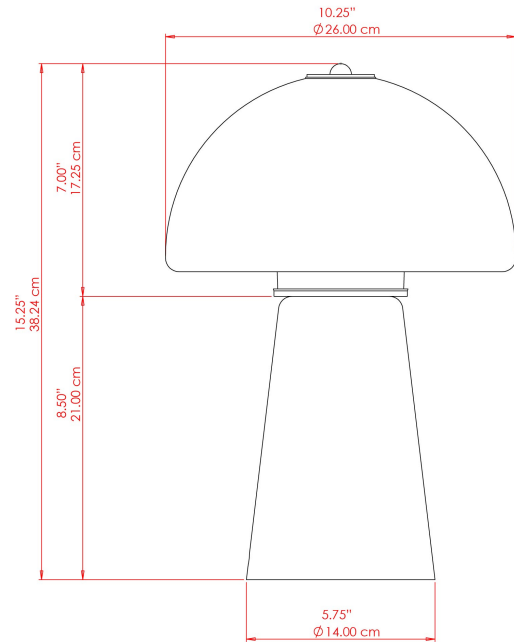

| | |
|---------------------------|---|
| MATERIAL | Brass Ceramic Steel Glass |
| HEIGHT | 15" |
| WIDTH DIAMETER | 10.25" |
| LENGTH PROJECTION | n/a |
| WEIGHT | 3.3 kg 7.3 lbs |
| LAMPHOLDER | E26 |
| MAX WATTAGE | 40W |
| VOLTAGE | 110/120v |
| ENVIRONMENTAL RATING | Dry Location (IP20) |
| CLASS PROTECTION | Class I |
| SHADE | GL203 |
| FLEX BAR CHAIN LENGTH | n/a |
| CABLE TYPE | MLCA029 Black Fabric Braided Cable 3 Core Round |

FIXING BRACKET: -



Product Notes:

1) Bulbs not included. 2) Dimensions do not include bulbs. 3) All products are individually made-to-order and therefore may differ slightly within manufacturing tolerances. 4) Cable / chain can be shortened during installation. Longer cable / chain lengths available on request. 5) Additional color finishes may be available on request. 6) Twisted cable is not available for UL wired products. Round cable in black or brown only is supplied instead. 7) Refer to our website for a full list of terms and conditions.

