

KAURI Ceramic Pendant

MLCMP062ANTBRS Antique Brass

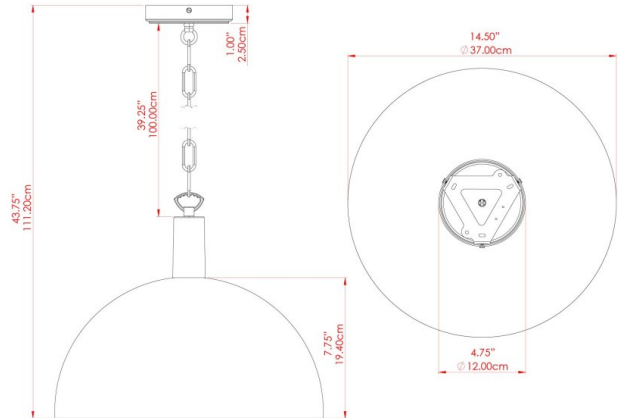

| | |
|---------------------------|---|
| MATERIAL | Brass Ceramic |
| HEIGHT | 28cm |
| WIDTH DIAMETER | 37cm |
| LENGTH PROJECTION | n/a |
| WEIGHT | 8.5 kg |
| LAMPHOLDER | E27 |
| MAX WATTAGE | 40W |
| VOLTAGE | 220/240v |
| IP RATING | IP20 |
| CLASS PROTECTION | Class I |
| SHADE | MLCS049 |
| FLEX BAR CHAIN LENGTH | 100cm |
| CABLE TYPE | MLCA010 Brown PVC Flexible Cable 2 Core |

FIXING BRACKET: MLWB17

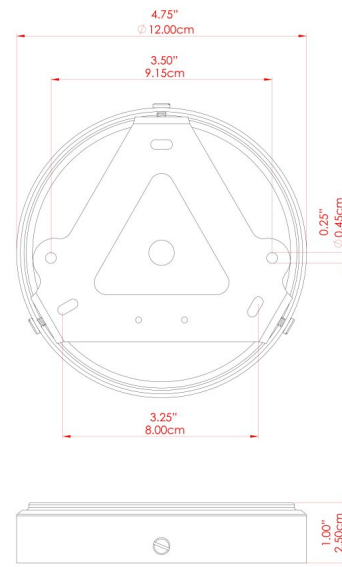

Product Notes:
 1) Bulbs not included. 2) Dimensions do not include bulbs. 3) All products are individually made-to-order and therefore may differ slightly within manufacturing tolerances. 4) Cable / chain can be shortened during installation. Longer cable / chain lengths available on request. 5) Additional colour finishes may be available on request. 6) Refer to our website for a full list of terms and conditions.



KAURI Ceramic Pendant

MLCMP062ANTSLV Antique Silver

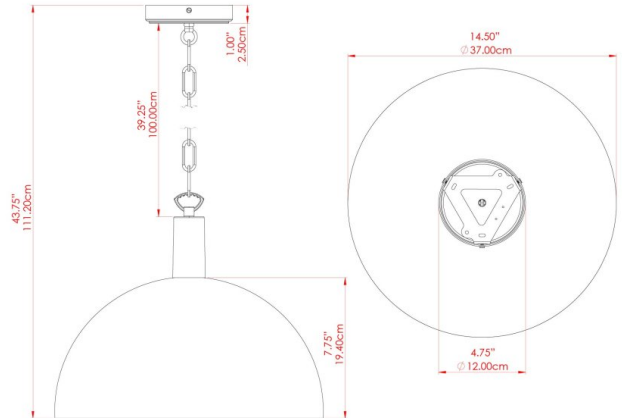

| | |
|---------------------------|---|
| MATERIAL | Brass Ceramic |
| HEIGHT | 28cm |
| WIDTH DIAMETER | 37cm |
| LENGTH PROJECTION | n/a |
| WEIGHT | 8.5 kg |
| LAMPHOLDER | E27 |
| MAX WATTAGE | 40W |
| VOLTAGE | 220/240v |
| IP RATING | IP20 |
| CLASS PROTECTION | Class I |
| SHADE | MLCS049 |
| FLEX BAR CHAIN LENGTH | 100cm |
| CABLE TYPE | MLCA014 Clear PVC Flexible Cable 2 Core |

FIXING BRACKET: MLWB17

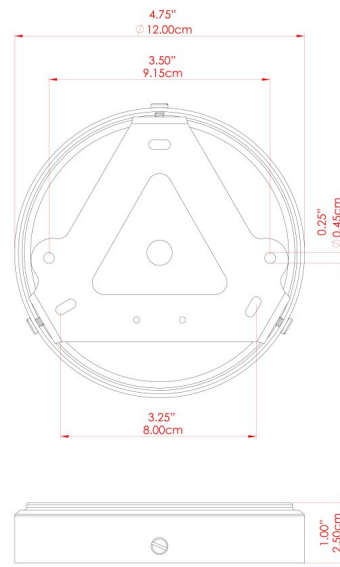

Product Notes:
 1) Bulbs not included. 2) Dimensions do not include bulbs. 3) All products are individually made-to-order and therefore may differ slightly within manufacturing tolerances. 4) Cable / chain can be shortened during installation. Longer cable / chain lengths available on request. 5) Additional colour finishes may be available on request. 6) Refer to our website for a full list of terms and conditions.



KAURI Ceramic Pendant

MLCMP062PCMBK Matt Black

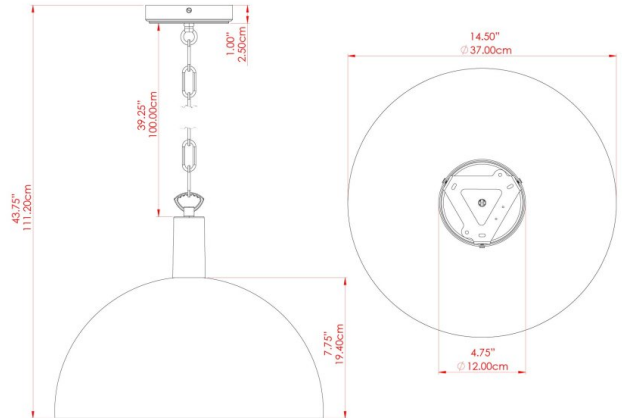

| | |
|---------------------------|---|
| MATERIAL | Brass Ceramic |
| HEIGHT | 28cm |
| WIDTH DIAMETER | 37cm |
| LENGTH PROJECTION | n/a |
| WEIGHT | 8.5 kg |
| LAMPHOLDER | E27 |
| MAX WATTAGE | 40W |
| VOLTAGE | 220/240v |
| IP RATING | IP20 |
| CLASS PROTECTION | Class I |
| SHADE | MLCS049 |
| FLEX BAR CHAIN LENGTH | 100cm |
| CABLE TYPE | MLCA009 Black PVC Flexible Cable 2 Core |

FIXING BRACKET: MLWB17

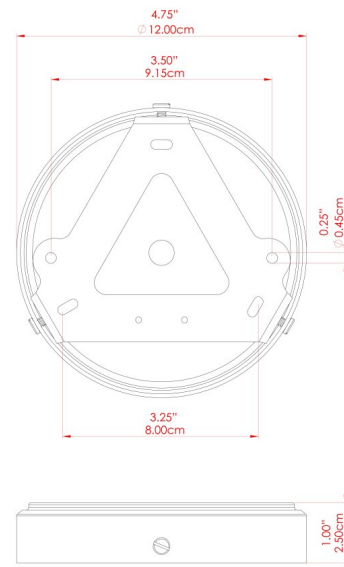

KAURI Ceramic Pendant

MLCMP062POLBRS Polished Brass

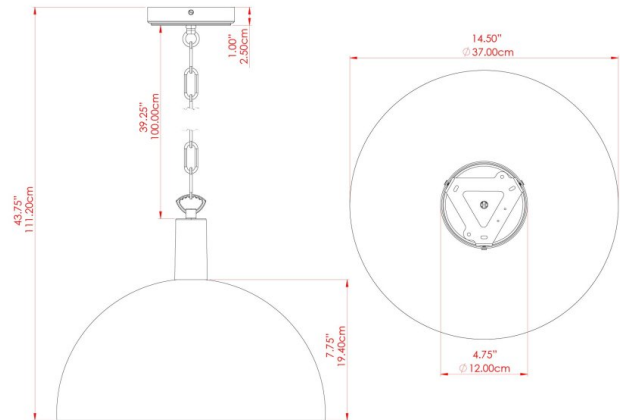

| | |
|---------------------------|--|
| MATERIAL | Brass Ceramic |
| HEIGHT | 28cm |
| WIDTH DIAMETER | 37cm |
| LENGTH PROJECTION | n/a |
| WEIGHT | 8.5 kg |
| LAMPHOLDER | E27 |
| MAX WATTAGE | 40W |
| VOLTAGE | 220/240v |
| IP RATING | IP20 |
| CLASS PROTECTION | Class I |
| SHADE | MLCS049 |
| FLEX BAR CHAIN LENGTH | 100cm |
| CABLE TYPE | MLCA038 Gold PVC Flexible Cable 2 Core |

FIXING BRACKET: MLWB17

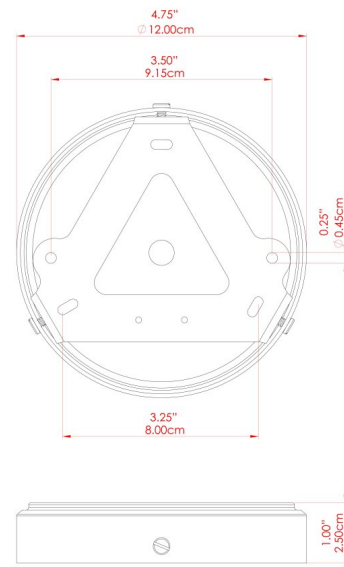

WWW.MULLANLIGHTING.COM

Product Notes:

1) Bulbs not included. 2) Dimensions do not include bulbs. 3) All products are individually made-to-order and therefore may differ slightly within manufacturing tolerances. 4) Cable / chain can be shortened during installation. Longer cable / chain lengths available on request. 5) Additional colour finishes may be available on request. 6) Refer to our website for a full list of terms and conditions.



KAURI Ceramic Pendant

MLCMP062SATBRS Satin Brass

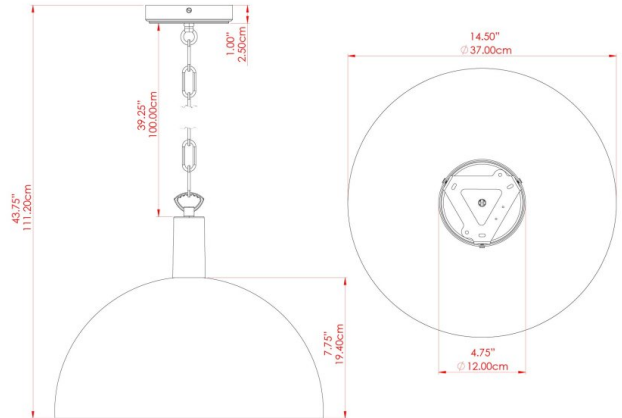

| | |
|---------------------------|--|
| MATERIAL | Brass Ceramic |
| HEIGHT | 28cm |
| WIDTH DIAMETER | 37cm |
| LENGTH PROJECTION | n/a |
| WEIGHT | 8.5 kg |
| LAMPHOLDER | E27 |
| MAX WATTAGE | 40W |
| VOLTAGE | 220/240v |
| IP RATING | IP20 |
| CLASS PROTECTION | Class I |
| SHADE | MLCS049 |
| FLEX BAR CHAIN LENGTH | 100cm |
| CABLE TYPE | MLCA038 Gold PVC Flexible Cable 2 Core |

FIXING BRACKET: MLWB17

