

# CHESTER Pendant

## MLP396ANTBRS Antique Brass

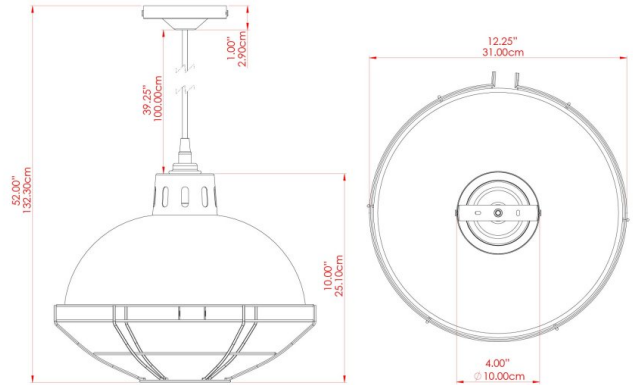

MATERIAL	Brass   Steel
HEIGHT	24cm
WIDTH   DIAMETER	32cm
LENGTH   PROJECTION	n/a
WEIGHT	1.4 kg
LAMPHOLDER	E27
MAX WATTAGE	40W
VOLTAGE	220/240v
IP RATING	IP20
CLASS PROTECTION	Class I
SHADE	-
FLEX   BAR   CHAIN LENGTH	100cm
CABLE TYPE	MLCA002   Brown Fabric Braided Cable   2 Core Twisted

### FIXING BRACKET: MLROSE05GRIP | Antique Brass

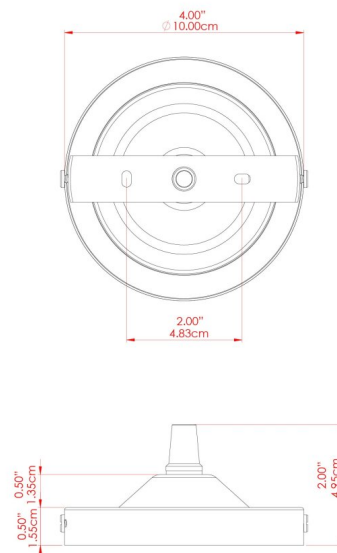

Product Notes:  
 1) Bulbs not included. 2) Dimensions do not include bulbs. 3) All products are individually made-to-order and therefore may differ slightly within manufacturing tolerances. 4) Cable / chain can be shortened during installation. Longer cable / chain lengths available on request. 5) Additional colour finishes may be available on request. 6) Refer to our website for a full list of terms and conditions.



# CHESTER Pendant

# MLP396ANTSLV Antique Silver

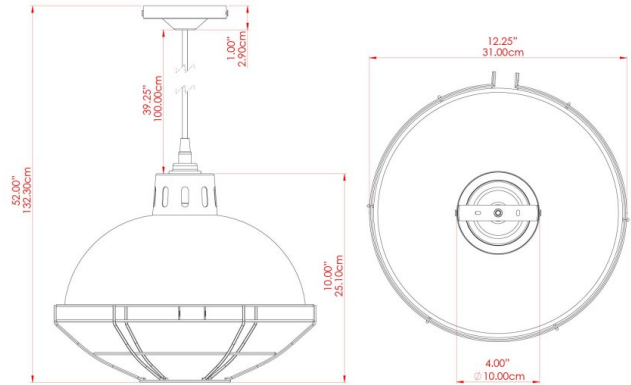

MATERIAL	Brass   Steel
HEIGHT	24cm
WIDTH   DIAMETER	32cm
LENGTH   PROJECTION	n/a
WEIGHT	1.4 kg
LAMPHOLDER	E27
MAX WATTAGE	40W
VOLTAGE	220/240v
IP RATING	IP20
CLASS PROTECTION	Class I
SHADE	-
FLEX   BAR   CHAIN LENGTH	100cm
CABLE TYPE	MLCA001   Black Fabric Braided Cable   2 Core Twisted

## FIXING BRACKET: MLROSE05GRIP | Antique Silver

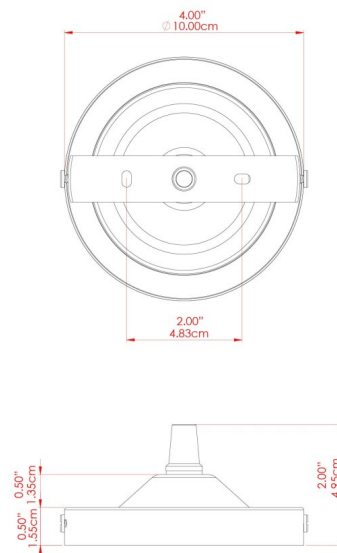

Product Notes:  
 1) Bulbs not included. 2) Dimensions do not include bulbs. 3) All products are individually made-to-order and therefore may differ slightly within manufacturing tolerances. 4) Cable / chain can be shortened during installation. Longer cable / chain lengths available on request. 5) Additional colour finishes may be available on request. 6) Refer to our website for a full list of terms and conditions.



# CHESTER Pendant

MLP396POLBRS Polished Brass

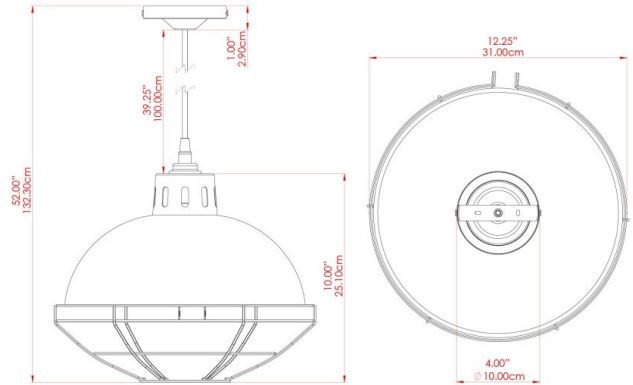

MATERIAL	Brass   Steel
HEIGHT	24cm
WIDTH   DIAMETER	32cm
LENGTH   PROJECTION	n/a
WEIGHT	1.4 kg
LAMPHOLDER	E27
MAX WATTAGE	40W
VOLTAGE	220/240v
IP RATING	IP20
CLASS PROTECTION	Class I
SHADE	-
FLEX   BAR   CHAIN LENGTH	100cm
CABLE TYPE	MLCA001   Black Fabric Braided Cable   2 Core Twisted

## FIXING BRACKET: MLROSE05GRIP | Polished Brass

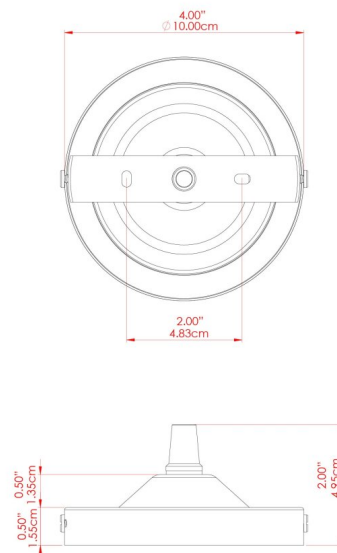

Product Notes:  
 1) Bulbs not included. 2) Dimensions do not include bulbs. 3) All products are individually made-to-order and therefore may differ slightly within manufacturing tolerances. 4) Cable / chain can be shortened during installation. Longer cable / chain lengths available on request. 5) Additional colour finishes may be available on request. 6) Refer to our website for a full list of terms and conditions.



# CHESTER Pendant

MLP396SATBRS Satin Brass

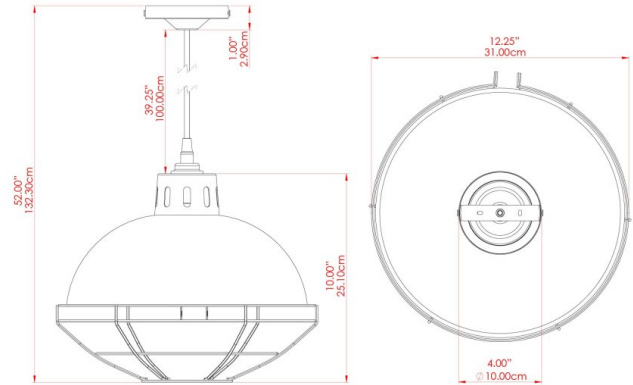

MATERIAL	Brass   Steel
HEIGHT	24cm
WIDTH   DIAMETER	32cm
LENGTH   PROJECTION	n/a
WEIGHT	1.4 kg
LAMPHOLDER	E27
MAX WATTAGE	40W
VOLTAGE	220/240v
IP RATING	IP20
CLASS PROTECTION	Class I
SHADE	-
FLEX   BAR   CHAIN LENGTH	100cm
CABLE TYPE	MLCA001   Black Fabric Braided Cable   2 Core Twisted

## FIXING BRACKET: MLROSE05GRIP | Satin Brass

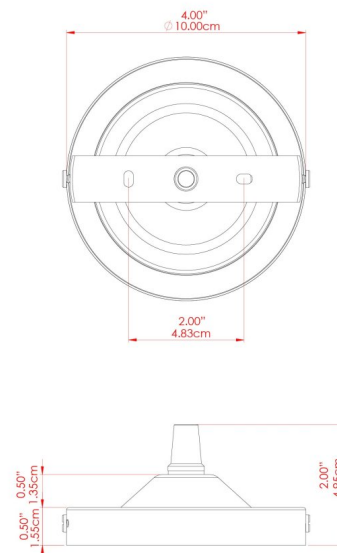

Product Notes:  
 1) Bulbs not included. 2) Dimensions do not include bulbs. 3) All products are individually made-to-order and therefore may differ slightly within manufacturing tolerances. 4) Cable / chain can be shortened during installation. Longer cable / chain lengths available on request. 5) Additional colour finishes may be available on request. 6) Refer to our website for a full list of terms and conditions.

