

STANLEY 20CM Pendant

MLP375ANTBRS Antique Brass

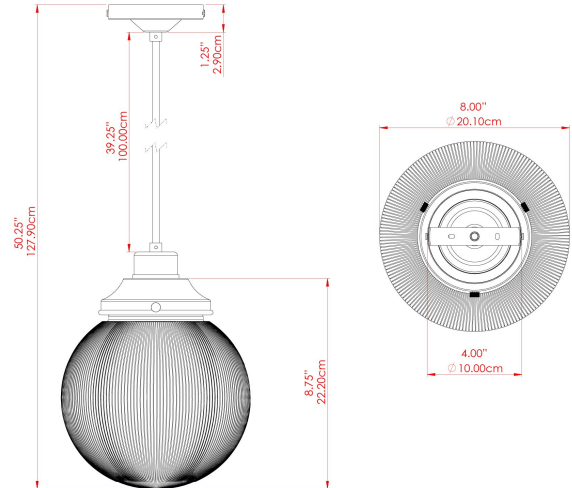

MATERIAL	Brass Glass
HEIGHT	26cm
WIDTH DIAMETER	20cm
LENGTH PROJECTION	n/a
WEIGHT	0.71 kg
LAMPHOLDER	E27
MAX WATTAGE	40W
VOLTAGE	220/240v
IP RATING	IP20
CLASS PROTECTION	Class I
SHADE	GL155
FLEX BAR CHAIN LENGTH	100cm
CABLE TYPE	MLCA002 Brown Fabric Braided Cable 2 Core Twisted

FIXING BRACKET: MLROSE05GRIP | Antique Brass

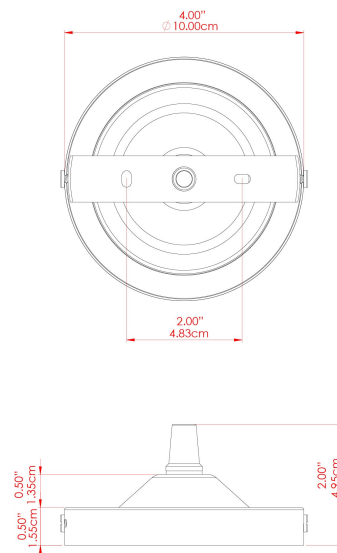

Product Notes:
 1) Bulbs not included. 2) Dimensions do not include bulbs. 3) All products are individually made-to-order and therefore may differ slightly within manufacturing tolerances. 4) Cable / chain can be shortened during installation. Longer cable / chain lengths available on request. 5) Additional colour finishes may be available on request. 6) Refer to our website for a full list of terms and conditions.



STANLEY 20CM Pendant

MLP375ANTSLV Antique Silver

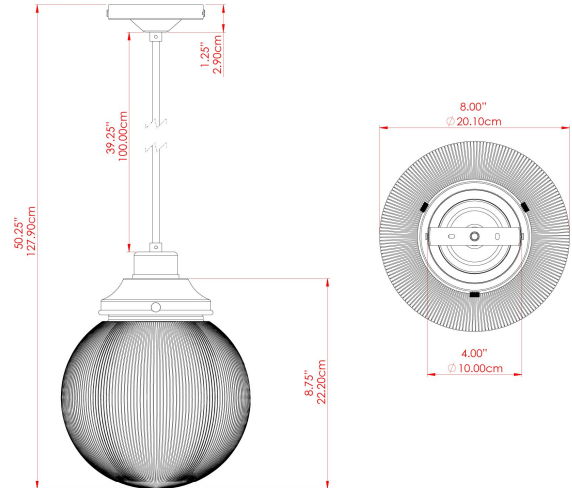

MATERIAL	Brass Glass
HEIGHT	22.2cm
WIDTH DIAMETER	20cm
LENGTH PROJECTION	n/a
WEIGHT	0.71 kg
LAMPHOLDER	E27
MAX WATTAGE	40W
VOLTAGE	220/240v
IP RATING	IP20
CLASS PROTECTION	Class I
SHADE	GL155
FLEX BAR CHAIN LENGTH	100cm
CABLE TYPE	MLCA001 Black Fabric Braided Cable 2 Core Twisted

FIXING BRACKET: MLROSE05GRIP | Antique Silver

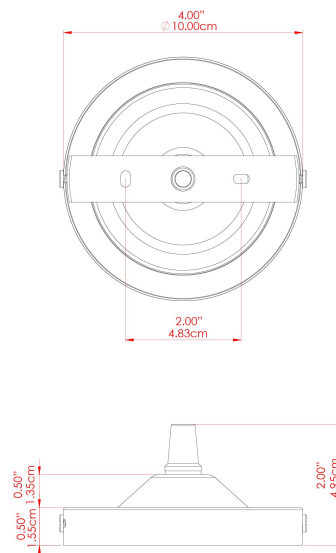

Product Notes:
 1) Bulbs not included. 2) Dimensions do not include bulbs. 3) All products are individually made-to-order and therefore may differ slightly within manufacturing tolerances. 4) Cable / chain can be shortened during installation. Longer cable / chain lengths available on request. 5) Additional colour finishes may be available on request. 6) Refer to our website for a full list of terms and conditions.



STANLEY 20CM Pendant

MLP375POLBRS Polished Brass

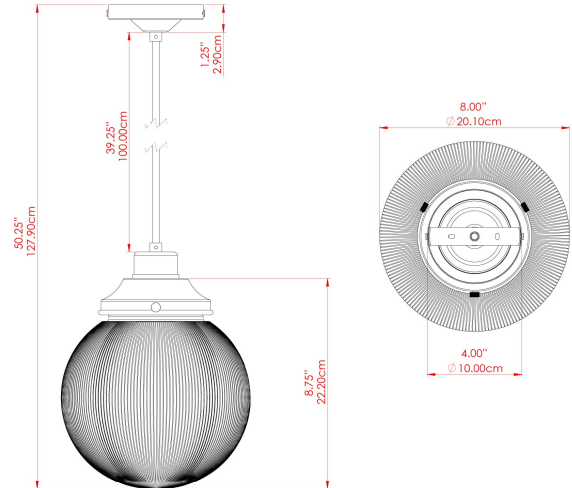

MATERIAL	Brass Glass
HEIGHT	22.2cm
WIDTH DIAMETER	20cm
LENGTH PROJECTION	n/a
WEIGHT	0.71 kg
LAMPHOLDER	E27
MAX WATTAGE	40W
VOLTAGE	220/240v
IP RATING	IP20
CLASS PROTECTION	Class I
SHADE	GL155
FLEX BAR CHAIN LENGTH	100cm
CABLE TYPE	MLCA001 Black Fabric Braided Cable 2 Core Twisted

FIXING BRACKET: MLROSE05GRIP | Polished Brass

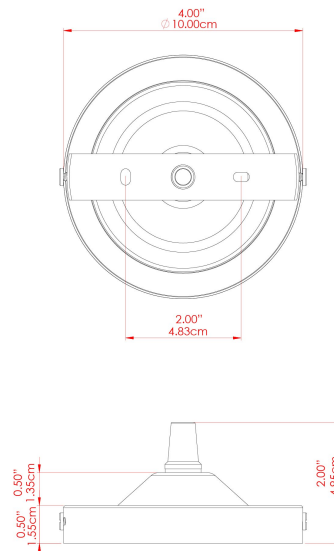

Product Notes:
 1) Bulbs not included. 2) Dimensions do not include bulbs. 3) All products are individually made-to-order and therefore may differ slightly within manufacturing tolerances. 4) Cable / chain can be shortened during installation. Longer cable / chain lengths available on request. 5) Additional colour finishes may be available on request. 6) Refer to our website for a full list of terms and conditions.



STANLEY 20CM Pendant

MLP375POLCHR Polished Chrome

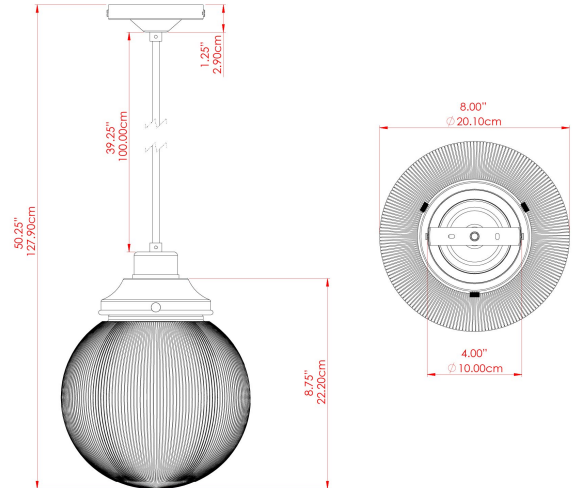

MATERIAL	Brass Glass
HEIGHT	22.2cm
WIDTH DIAMETER	20cm
LENGTH PROJECTION	n/a
WEIGHT	0.71 kg
LAMPHOLDER	E27
MAX WATTAGE	40W
VOLTAGE	220/240v
IP RATING	IP20
CLASS PROTECTION	Class I
SHADE	GL155
FLEX BAR CHAIN LENGTH	100cm
CABLE TYPE	MLCA001 Black Fabric Braided Cable 2 Core Twisted

FIXING BRACKET: MLROSE05GRIP | Polished Chrome

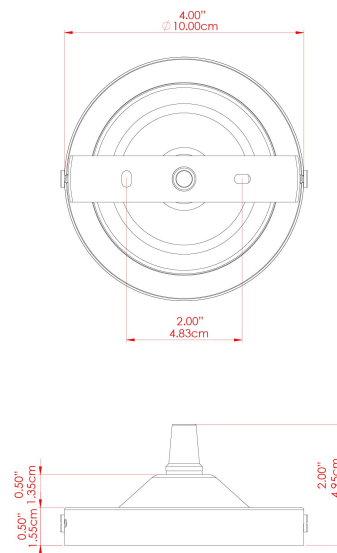

Product Notes:
 1) Bulbs not included. 2) Dimensions do not include bulbs. 3) All products are individually made-to-order and therefore may differ slightly within manufacturing tolerances. 4) Cable / chain can be shortened during installation. Longer cable / chain lengths available on request. 5) Additional colour finishes may be available on request. 6) Refer to our website for a full list of terms and conditions.



STANLEY 20CM Pendant

MLP375SATBRS Satin Brass

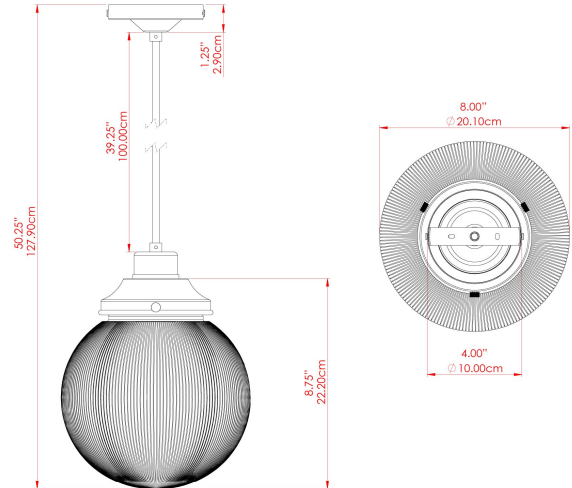

MATERIAL	Brass Glass
HEIGHT	22.2cm
WIDTH DIAMETER	20cm
LENGTH PROJECTION	n/a
WEIGHT	0.71 kg
LAMPHOLDER	E27
MAX WATTAGE	40W
VOLTAGE	220/240v
IP RATING	IP20
CLASS PROTECTION	Class I
SHADE	GL155
FLEX BAR CHAIN LENGTH	100cm
CABLE TYPE	MLCA001 Black Fabric Braided Cable 2 Core Twisted

FIXING BRACKET: MLROSE05GRIP | Satin Brass

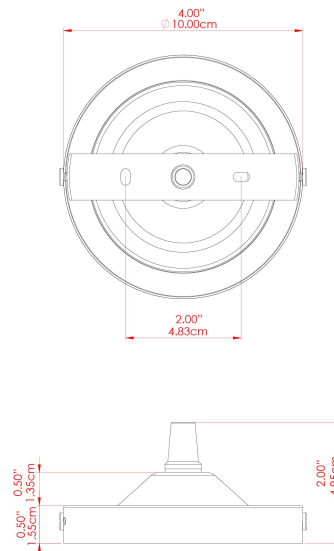

Product Notes:
 1) Bulbs not included. 2) Dimensions do not include bulbs. 3) All products are individually made-to-order and therefore may differ slightly within manufacturing tolerances. 4) Cable / chain can be shortened during installation. Longer cable / chain lengths available on request. 5) Additional colour finishes may be available on request. 6) Refer to our website for a full list of terms and conditions.



STANLEY 20CM Pendant

MLP375SATCHR Satin Chrome

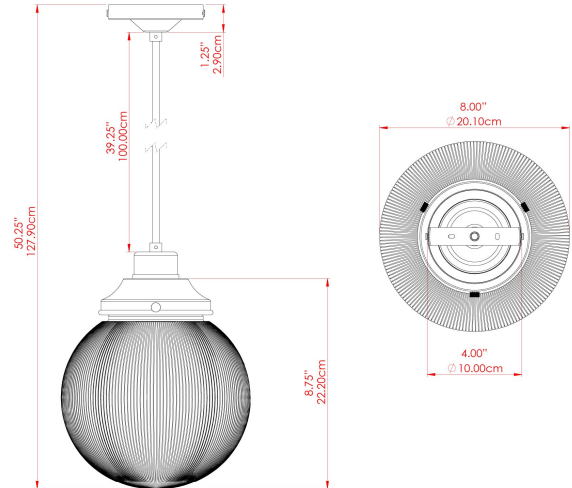

MATERIAL	Brass Glass
HEIGHT	22.2cm
WIDTH DIAMETER	20cm
LENGTH PROJECTION	n/a
WEIGHT	0.71 kg
LAMPHOLDER	E27
MAX WATTAGE	40W
VOLTAGE	220/240v
IP RATING	IP20
CLASS PROTECTION	Class I
SHADE	GL155
FLEX BAR CHAIN LENGTH	100cm
CABLE TYPE	MLCA001 Black Fabric Braided Cable 2 Core Twisted

FIXING BRACKET: MLROSE05GRIP | Satin Chrome

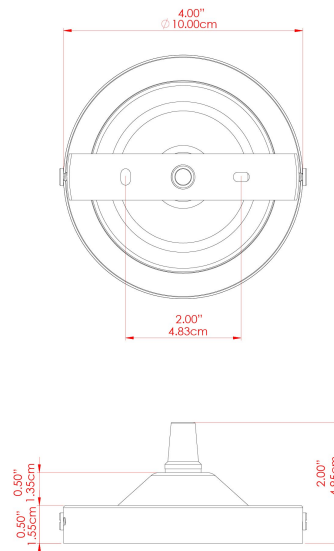

Product Notes:
 1) Bulbs not included. 2) Dimensions do not include bulbs. 3) All products are individually made-to-order and therefore may differ slightly within manufacturing tolerances. 4) Cable / chain can be shortened during installation. Longer cable / chain lengths available on request. 5) Additional colour finishes may be available on request. 6) Refer to our website for a full list of terms and conditions.

