

CLERMONT Chandelier

MLF354ANTBRS Antique Brass

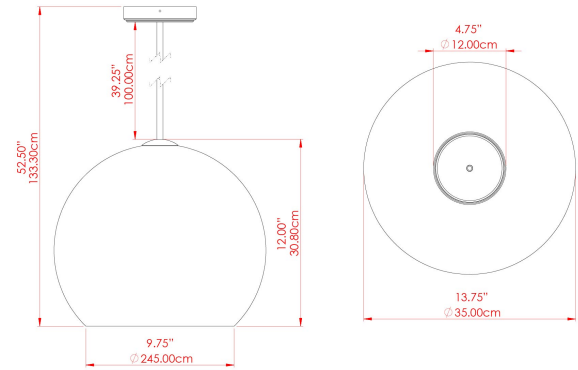

MATERIAL	Brass Steel
HEIGHT	95cm
WIDTH DIAMETER	35cm
LENGTH PROJECTION	n/a
WEIGHT	2.8 kg
LAMPHOLDER	E14
MAX WATTAGE	40W
VOLTAGE	220/240v
IP RATING	IP20
CLASS PROTECTION	Class I
SHADE	GL134
FLEX BAR CHAIN LENGTH	100cm
CABLE TYPE	-

FIXING BRACKET: MLWB17

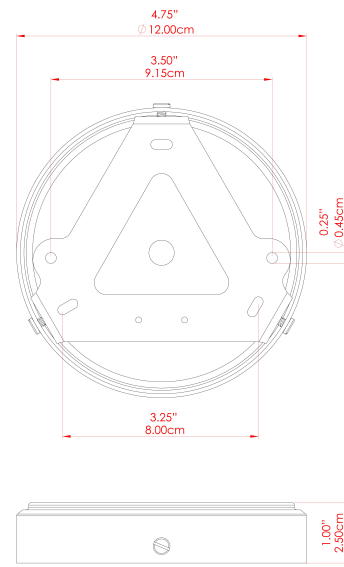

CLERMONT Chandelier

MLF354ANTSLV Antique Silver

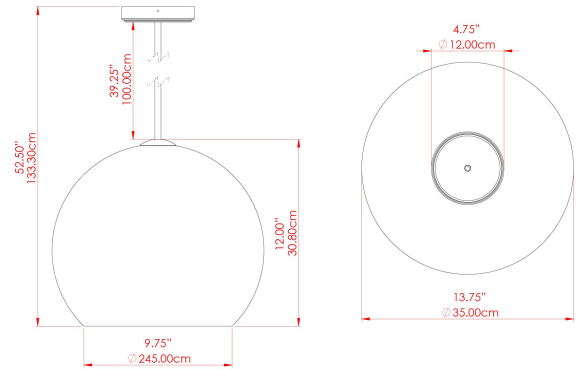

MATERIAL	Brass Steel
HEIGHT	95cm
WIDTH DIAMETER	35cm
LENGTH PROJECTION	n/a
WEIGHT	2.8 kg
LAMPHOLDER	E14
MAX WATTAGE	40W
VOLTAGE	220/240v
IP RATING	IP20
CLASS PROTECTION	Class I
SHADE	GL134
FLEX BAR CHAIN LENGTH	100cm
CABLE TYPE	-

FIXING BRACKET: MLWB17



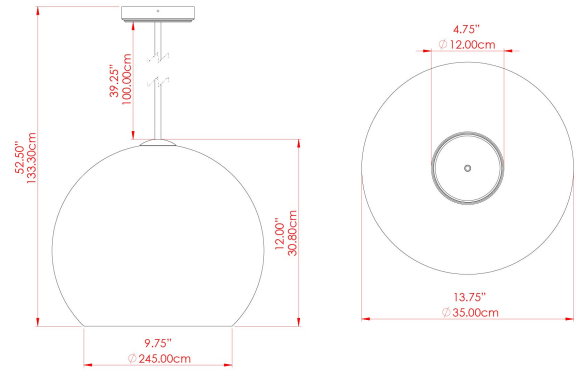

MATERIAL	Brass Steel
HEIGHT	95cm
WIDTH DIAMETER	35cm
LENGTH PROJECTION	n/a
WEIGHT	2.8 kg
LAMPHOLDER	E14
MAX WATTAGE	40W
VOLTAGE	220/240v
IP RATING	IP20
CLASS PROTECTION	Class I
SHADE	GL134
FLEX BAR CHAIN LENGTH	100cm
CABLE TYPE	-

FIXING BRACKET: MLWB17

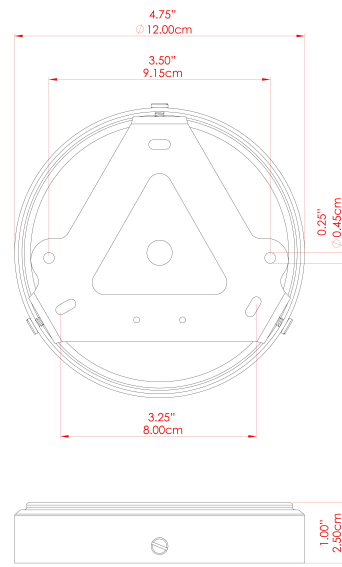

WWW.MULLANLIGHTING.COM

Product Notes:

1) Bulbs not included. 2) Dimensions do not include bulbs. 3) All products are individually made-to-order and therefore may differ slightly within manufacturing tolerances. 4) Cable / chain can be shortened during installation. Longer cable / chain lengths available on request. 5) Additional colour finishes may be available on request. 6) Refer to our website for a full list of terms and conditions.



CLERMONT Chandelier

MLF354POLBRS Polished Brass

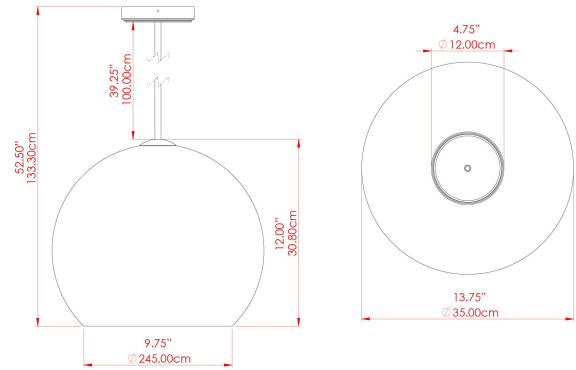

MATERIAL	Brass Steel
HEIGHT	95cm
WIDTH DIAMETER	35cm
LENGTH PROJECTION	n/a
WEIGHT	2.8 kg
LAMPHOLDER	E14
MAX WATTAGE	40W
VOLTAGE	220/240v
IP RATING	IP20
CLASS PROTECTION	Class I
SHADE	GL134
FLEX BAR CHAIN LENGTH	100cm
CABLE TYPE	-

FIXING BRACKET: MLWB17

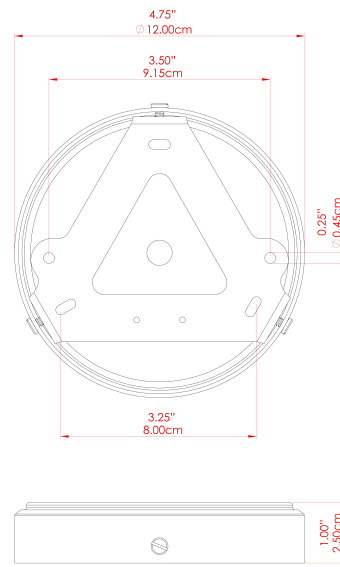

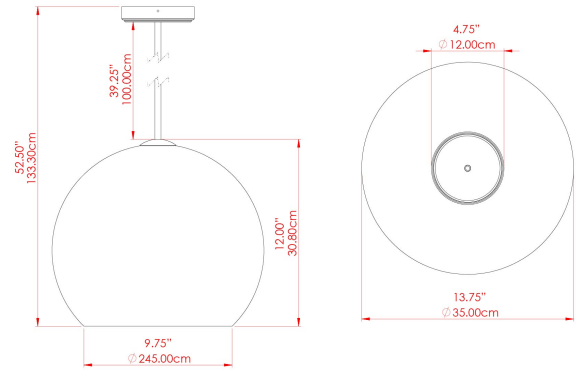

MATERIAL	Brass Steel
HEIGHT	95cm
WIDTH DIAMETER	35cm
LENGTH PROJECTION	n/a
WEIGHT	2.8 kg
LAMPHOLDER	E14
MAX WATTAGE	40W
VOLTAGE	220/240v
IP RATING	IP20
CLASS PROTECTION	Class I
SHADE	GL134
FLEX BAR CHAIN LENGTH	100cm
CABLE TYPE	-

FIXING BRACKET: MLWB17

