

# SEVILLE Ceramic Pendant

# MLCMP084ANTBRS Antique Brass

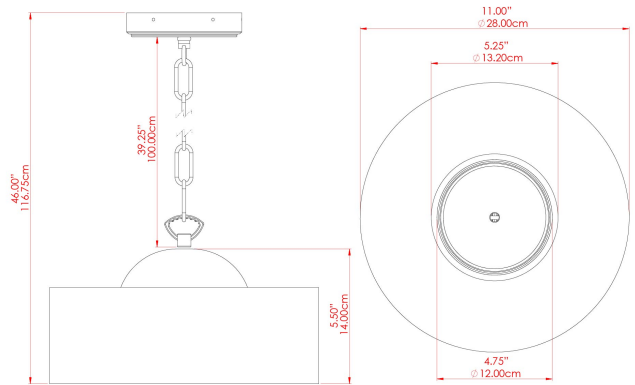

|                           |   |
|---------------------------|---|
| MATERIAL                  | Brass   Ceramic                             |
| HEIGHT                    | 15.5cm                                      |
| WIDTH   DIAMETER          | 28cm  |
| LENGTH   PROJECTION       | n/a   |
| WEIGHT                    | 3.5 kg                                      |
| LAMPHOLDER                | E27   |
| MAX WATTAGE               | 40W   |
| VOLTAGE                   | 220/240v                                    |
| IP RATING                 | IP20  |
| CLASS PROTECTION          | Class I                                     |
| SHADE                     | MLL037   MLCS086                            |
| FLEX   BAR   CHAIN LENGTH | 100cm                                       |
| CABLE TYPE                | MLCA010   Brown PVC Flexible Cable   2 Core |

### FIXING BRACKET: MLWB17



# SEVILLE Ceramic Pendant

# MLCMP084ANTSLV Antique Silver

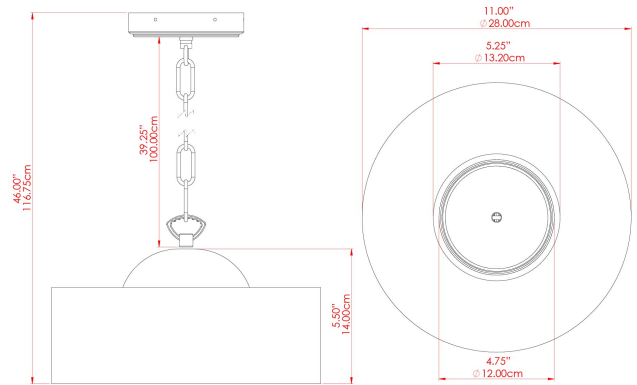

|                           |   |
|---------------------------|---|
| MATERIAL                  | Brass   Ceramic                             |
| HEIGHT                    | 15.5cm                                      |
| WIDTH   DIAMETER          | 28cm  |
| LENGTH   PROJECTION       | n/a   |
| WEIGHT                    | 3.5 kg                                      |
| LAMPHOLDER                | E27   |
| MAX WATTAGE               | 40W   |
| VOLTAGE                   | 220/240v                                    |
| IP RATING                 | IP20  |
| CLASS PROTECTION          | Class I                                     |
| SHADE                     | MLL037   MLCS086                            |
| FLEX   BAR   CHAIN LENGTH | 100cm                                       |
| CABLE TYPE                | MLCA014   Clear PVC Flexible Cable   2 Core |

### FIXING BRACKET: MLWB17

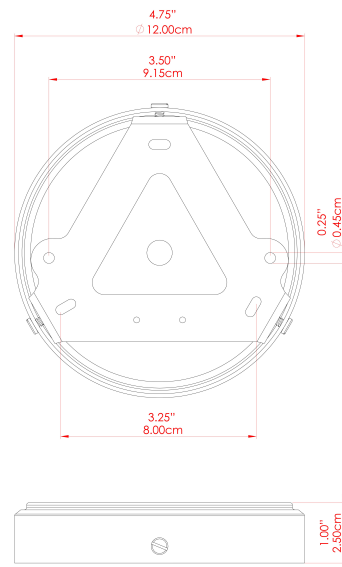

# SEVILLE Ceramic Pendant

MLCMP084PCMBK Matt Black

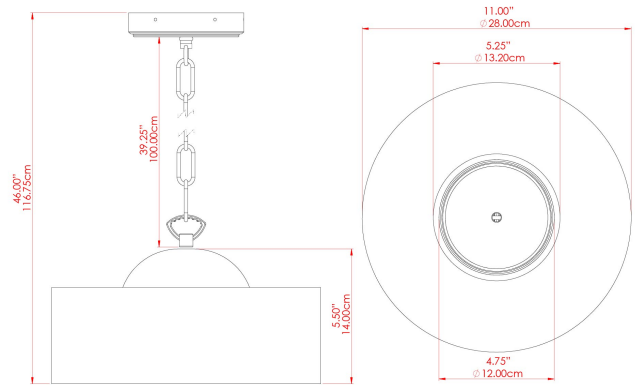

|                           |   |
|---------------------------|---|
| MATERIAL                  | Brass   Ceramic                             |
| HEIGHT                    | 15.5cm                                      |
| WIDTH   DIAMETER          | 28cm  |
| LENGTH   PROJECTION       | n/a   |
| WEIGHT                    | 3.5 kg                                      |
| LAMPHOLDER                | E27   |
| MAX WATTAGE               | 40W   |
| VOLTAGE                   | 220/240v                                    |
| IP RATING                 | IP20  |
| CLASS PROTECTION          | Class I                                     |
| SHADE                     | MLL037   MLCS086                            |
| FLEX   BAR   CHAIN LENGTH | 100cm                                       |
| CABLE TYPE                | MLCA009   Black PVC Flexible Cable   2 Core |

## FIXING BRACKET: MLWB17



Product Notes:  
 1) Bulbs not included. 2) Dimensions do not include bulbs. 3) All products are individually made-to-order and therefore may differ slightly within manufacturing tolerances. 4) Cable / chain can be shortened during installation. Longer cable / chain lengths available on request. 5) Additional colour finishes may be available on request. 6) Refer to our website for a full list of terms and conditions.



# SEVILLE Ceramic Pendant

# MLCMP084POLBRS Polished Brass

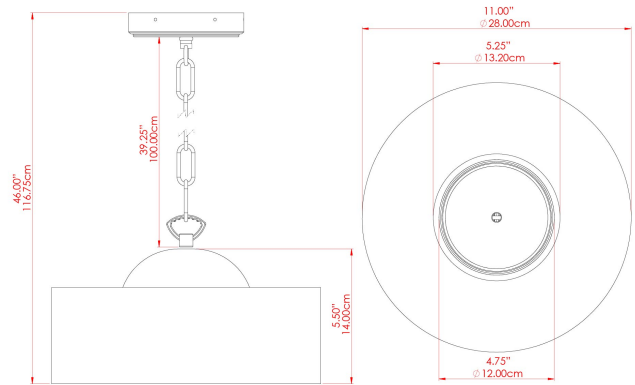

|                           |  |
|---------------------------|--|
| MATERIAL                  | Brass   Ceramic                            |
| HEIGHT                    | 15.5cm                                     |
| WIDTH   DIAMETER          | 28cm                                       |
| LENGTH   PROJECTION       | n/a  |
| WEIGHT                    | 3.5 kg                                     |
| LAMPHOLDER                | E27  |
| MAX WATTAGE               | 40W  |
| VOLTAGE                   | 220/240v                                   |
| IP RATING                 | IP20                                       |
| CLASS PROTECTION          | Class I                                    |
| SHADE                     | MLL037   MLCS086                           |
| FLEX   BAR   CHAIN LENGTH | 100cm                                      |
| CABLE TYPE                | MLCA038   Gold PVC Flexible Cable   2 Core |

### FIXING BRACKET: MLWB17

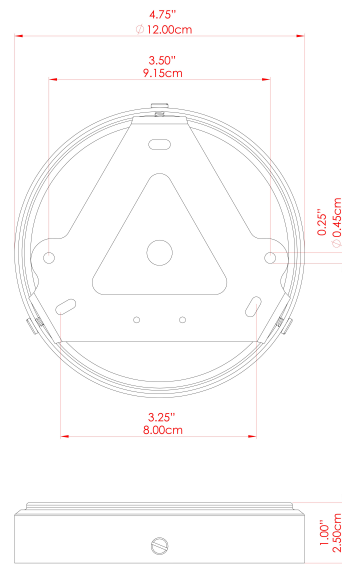

# SEVILLE Ceramic Pendant

MLCMP084SATBRS Satin Brass

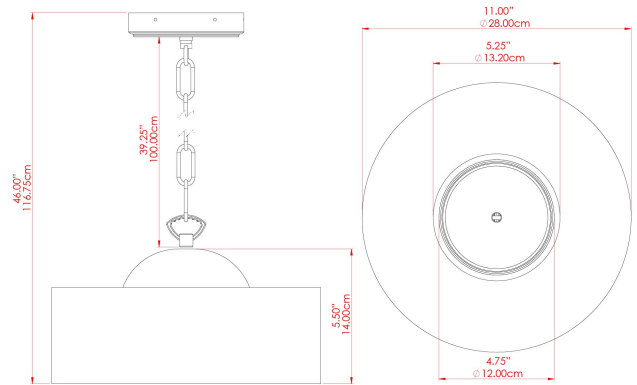

|                           |  |
|---------------------------|--|
| MATERIAL                  | Brass   Ceramic                            |
| HEIGHT                    | 15.5cm                                     |
| WIDTH   DIAMETER          | 28cm                                       |
| LENGTH   PROJECTION       | n/a  |
| WEIGHT                    | 3.5 kg                                     |
| LAMPHOLDER                | E27  |
| MAX WATTAGE               | 40W  |
| VOLTAGE                   | 220/240v                                   |
| IP RATING                 | IP20                                       |
| CLASS PROTECTION          | Class I                                    |
| SHADE                     | MLL037   MLCS086                           |
| FLEX   BAR   CHAIN LENGTH | 100cm                                      |
| CABLE TYPE                | MLCA038   Gold PVC Flexible Cable   2 Core |

### FIXING BRACKET: MLWB17

