

# SEVILLE Ceramic Pendant

# MLCMP079ANTBRS Antique Brass

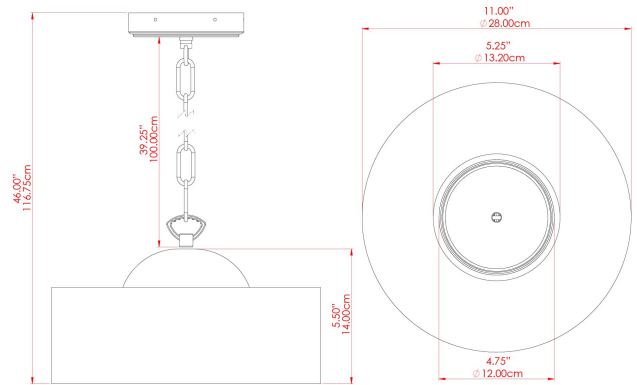

MATERIAL	Brass   Ceramic
HEIGHT	15.5cm
WIDTH   DIAMETER	28cm
LENGTH   PROJECTION	n/a
WEIGHT	3.5 kg
LAMPHOLDER	E27
MAX WATTAGE	40W
VOLTAGE	220/240v
IP RATING	IP20
CLASS PROTECTION	Class I
SHADE	MLL037   MLCS081
FLEX   BAR   CHAIN LENGTH	100cm
CABLE TYPE	MLCA010   Brown PVC Flexible Cable   2 Core

### FIXING BRACKET: MLWB17

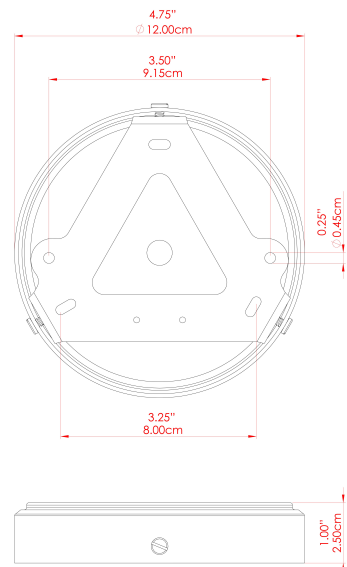

# SEVILLE Ceramic Pendant

# MLCMP079ANTSLV Antique Silver

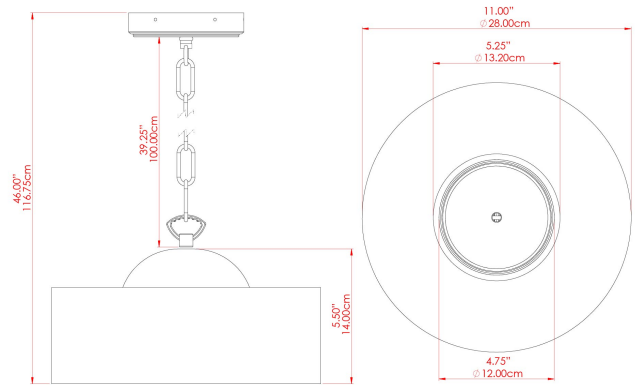

MATERIAL	Brass   Ceramic
HEIGHT	15.5cm
WIDTH   DIAMETER	28cm
LENGTH   PROJECTION	n/a
WEIGHT	3.5 kg
LAMPHOLDER	E27
MAX WATTAGE	40W
VOLTAGE	220/240v
IP RATING	IP20
CLASS PROTECTION	Class I
SHADE	MLL037   MLCS081
FLEX   BAR   CHAIN LENGTH	100cm
CABLE TYPE	MLCA014   Clear PVC Flexible Cable   2 Core

### FIXING BRACKET: MLWB17



Product Notes:  
 1) Bulbs not included. 2) Dimensions do not include bulbs. 3) All products are individually made-to-order and therefore may differ slightly within manufacturing tolerances. 4) Cable / chain can be shortened during installation. Longer cable / chain lengths available on request. 5) Additional colour finishes may be available on request. 6) Refer to our website for a full list of terms and conditions.



# SEVILLE Ceramic Pendant

MLCMP079PCMBK Matt Black

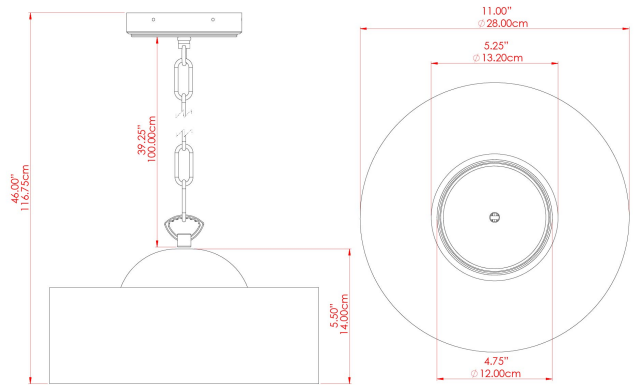

MATERIAL	Brass   Ceramic
HEIGHT	15.5cm
WIDTH   DIAMETER	28cm
LENGTH   PROJECTION	n/a
WEIGHT	3.5 kg
LAMPHOLDER	E27
MAX WATTAGE	40W
VOLTAGE	220/240v
IP RATING	IP20
CLASS PROTECTION	Class I
SHADE	MLL037   MLCS081
FLEX   BAR   CHAIN LENGTH	100cm
CABLE TYPE	MLCA009   Black PVC Flexible Cable   2 Core

## FIXING BRACKET: MLWB17



Product Notes:  
 1) Bulbs not included. 2) Dimensions do not include bulbs. 3) All products are individually made-to-order and therefore may differ slightly within manufacturing tolerances. 4) Cable / chain can be shortened during installation. Longer cable / chain lengths available on request. 5) Additional colour finishes may be available on request. 6) Refer to our website for a full list of terms and conditions.



# SEVILLE Ceramic Pendant

MLCMP079POLBRS Polished Brass

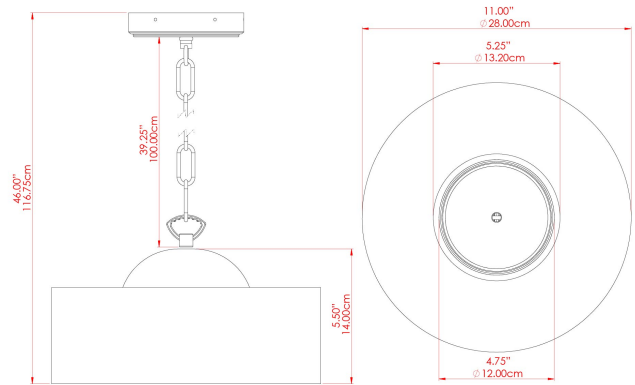

MATERIAL	Brass   Ceramic
HEIGHT	15.5cm
WIDTH   DIAMETER	28cm
LENGTH   PROJECTION	n/a
WEIGHT	3.5 kg
LAMPHOLDER	E27
MAX WATTAGE	40W
VOLTAGE	220/240v
IP RATING	IP20
CLASS PROTECTION	Class I
SHADE	MLL037   MLCS081
FLEX   BAR   CHAIN LENGTH	100cm
CABLE TYPE	MLCA038   Gold PVC Flexible Cable   2 Core

### FIXING BRACKET: MLWB17

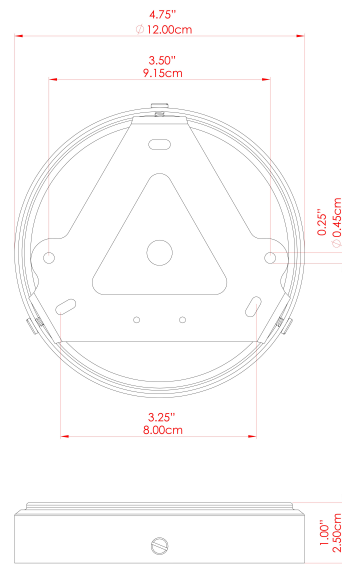

# SEVILLE Ceramic Pendant

MLCMP079SATBRS Satin Brass

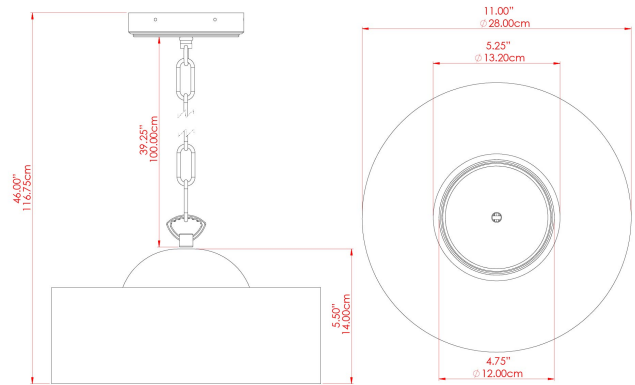

MATERIAL	Brass   Ceramic
HEIGHT	15.5cm
WIDTH   DIAMETER	28cm
LENGTH   PROJECTION	n/a
WEIGHT	3.5 kg
LAMPHOLDER	E27
MAX WATTAGE	40W
VOLTAGE	220/240v
IP RATING	IP20
CLASS PROTECTION	Class I
SHADE	MLL037   MLCS081
FLEX   BAR   CHAIN LENGTH	100cm
CABLE TYPE	MLCA038   Gold PVC Flexible Cable   2 Core

### FIXING BRACKET: MLWB17

