

MATERIAL	Brass Glass
HEIGHT	13cm
WIDTH DIAMETER	9.5cm
LENGTH PROJECTION	9cm
WEIGHT	0.79 kg
LAMPHOLDER	GU10
MAX WATTAGE	6.5W
VOLTAGE	220/240v
IP RATING	IP54
CLASS PROTECTION	Class I
SHADE	-
FLEX BAR CHAIN LENGTH	n/a
CABLE TYPE	-

FIXING BRACKET: -



WWW.MULLANLIGHTING.COM

Product Notes:

1) Bulbs not included. 2) Dimensions do not include bulbs. 3) All products are individually made-to-order and therefore may differ slightly within manufacturing tolerances. 4) Cable / chain can be shortened during installation. Longer cable / chain lengths available on request. 5) Additional colour finishes may be available on request. 6) Refer to our website for a full list of terms and conditions.



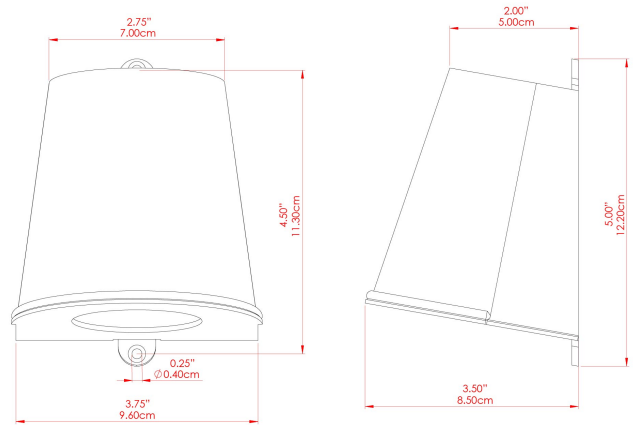

MATERIAL	Brass Glass
HEIGHT	13cm
WIDTH DIAMETER	9.5cm
LENGTH PROJECTION	9cm
WEIGHT	0.79 kg
LAMPHOLDER	GU10
MAX WATTAGE	6.5W
VOLTAGE	220/240v
IP RATING	IP54
CLASS PROTECTION	Class I
SHADE	-
FLEX BAR CHAIN LENGTH	n/a
CABLE TYPE	-

FIXING BRACKET: -



WWW.MULLANLIGHTING.COM

Product Notes:

1) Bulbs not included. 2) Dimensions do not include bulbs. 3) All products are individually made-to-order and therefore may differ slightly within manufacturing tolerances. 4) Cable / chain can be shortened during installation. Longer cable / chain lengths available on request. 5) Additional colour finishes may be available on request. 6) Refer to our website for a full list of terms and conditions.



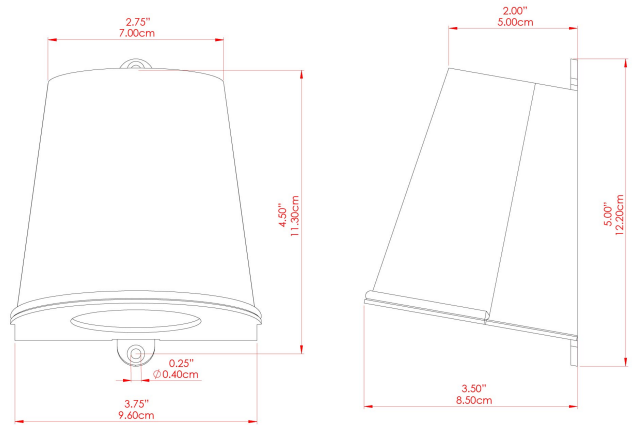

MATERIAL	Brass Glass
HEIGHT	13cm
WIDTH DIAMETER	9.5cm
LENGTH PROJECTION	9cm
WEIGHT	0.79 kg
LAMPHOLDER	GU10
MAX WATTAGE	6.5W
VOLTAGE	220/240v
IP RATING	IP54
CLASS PROTECTION	Class I
SHADE	-
FLEX BAR CHAIN LENGTH	n/a
CABLE TYPE	-

FIXING BRACKET: -



WWW.MULLANLIGHTING.COM

Product Notes:

1) Bulbs not included. 2) Dimensions do not include bulbs. 3) All products are individually made-to-order and therefore may differ slightly within manufacturing tolerances. 4) Cable / chain can be shortened during installation. Longer cable / chain lengths available on request. 5) Additional colour finishes may be available on request. 6) Refer to our website for a full list of terms and conditions.

